

TOWN OF CLIFTON PARK TOWN BOARD MEETING

Tuesday, October 11, 2022

The Town Board meeting can be viewed live by visiting www.cliftonpark.org Scroll down to click



- I. Call to Order/7:00 P. M. – Wood Room, Town Hall**
- II. Pledge to Flag**
- III. Roll Call**
- IV. Approval of Town Board Minutes**
- V. Communications/Announcements**
- VI. Business**
 - **Resolutions for Consideration**
 - **Other Business**
- VII. Open Public Privilege**

NOTE:

Please check www.cliftonpark.org for final agenda and updates. Each speaker shall state name and address prior to addressing the Board and shall be granted the floor for a single time frame of up to five minutes. The Board asks that members of the public respect the opportunity of the speaker at the podium to be heard, and asks that the public refrain from conducting side meetings within the meeting room. In an effort to ensure that the widest number of community viewpoints are heard, the Board asks members of groups or the public to withhold comment, if their viewpoints have already been presented. The Board thanks everyone in attendance for their understanding and also for their desire to actively participate in the Town decision making process.

- VIII. Adjournment**

Resolutions for Consideration
Clifton Park Town Board Meeting
October 11, 2022

<u>SOURCE</u>	<u>RESOLUTION</u>	<u>CONTACT</u>
1. Procurement – Highway	Authorize Change Order #1 to the Highway Awning Project	D. Bull
2. Procurement – Highway	Authorize the Highway Department to purchase a boom mower under Sourcewell Contract #070821 per Procurement Policy #16	D. Bull
3. Claims – Highway	Authorize the acceptance of final insurance payout from Selective Insurance for claims made due to the August 17, 2021 fire on Town property	D. Bull
4. Authorization - Highway	Authorize the Mohawk Towpath Byway to use town roadways for a duathlon on October 16, 2022	D. Bull
5. Appointment – Town Board	Appoint Everett Noakes to the Industrial Development Agency for a 3-year term	P. Barrett

RESOLUTION
#1

Resolution No. _____ of 2022, a resolution authorizing Change Order #1 for a bid awarded for construction of a permanent awning at the Highway Department.

Introduced by _____ who moved its adoption, seconded by _____.

WHEREAS, by Resolution No. 286 of 2021, the Town Board awarded a bid to Gallo Construction Corp. of Watervliet, NY to construct a permanent awning at the Highway facility, and

WHEREAS, the Superintendent of Highways has submitted a request for additional funding, due to the addition of tin siding and additional bird netting that was not in the original plans, and

WHEREAS, the Superintendent of Highways recommends accepting Change Order #1, to cover the additional costs involved; now, therefore, be it

RESOLVED, that the Comptroller is authorized to charge \$967.15 from A-05132-200 (General Fund- Garage Highway-Equipment); and be it further

RESOLVED, that Mr. Bull is authorized to accept Change Order #1 from Gallo Construction, in an amount not to exceed \$967.15, for the additional work.

Meg Springli

From: noreply
Sent: Tuesday, October 4, 2022 10:25 AM
To: Meg Springli
Cc: Jean, Spiegel; Mark Heggen; Tom McCarthy
Subject: Resolution Request for TB Meeting: 10-11-2022 Highway Department
Attachments: 633c422a6057a-Backup for Change Order for Highway Awning.pdf

An item has been submitted to the Resolution Request form for review.

Department: **Highway Department**
Your email: **dbull@cliftonpark.org**

Sponsor/Contact as shown on the agenda (i.e. P. Barrett, A. Standaert, D. Bull, etc.): **D. Bull**

Requested Meeting Date: **10-11-2022**

Brief Description: **Change order of \$967.15 for the construction of an Awning at the Highway Department.**
Resolution 286 of 2021

Budget #: **A-05132-0200**
Budget Description: **General Fund - Garage Highway - Equipment**
\$ Amount: **\$967.15**

Additional Comments/Details: **Increase was due to the addition of tin siding and additional bird netting that was not in the original plans for the structure.**

COMPTROLLER APPROVAL or Comments:

ATTORNEY APPROVAL or Comments:



Gallo Construction Corp.
 50 Lincoln Avenue, Watervliet, NY 12189
 Phone 518.273.0234 Fax 518.273.0245

INVOICE

INVOICE: 21166-02
 DATE: June 6, 2022

FILE COPY

To: Town of Clifton Park
 639 Clifton Park Center Rd
 Clifton Park, NY 12065
 Attn: Accounts Payable

Job	PO	Sales Rep	Payment Terms	Due Date
21166	Contract	Mike Gallo	Net 30	7/6/2022

Date	AIA	Description	Total
5/31/2022	AIA 2	Clifton Park Highway Garage Awning	\$ 45,979.96
		Gross Invoice Amt: 42,828.00 Plus Retainage Helod: <u>3,151.96</u> Net Invoice Due: 45,979.96	
		$ \begin{array}{r} 59,887.19 \\ + 45,979.96 \\ \hline 105,867.15 \\ - 104,900.00 \text{ 286-3-2022} \\ \hline \text{\$967.15} \end{array} $	

Subtotal	\$ 45,979.96
Sales Tax	Exempt
Total	\$ 45,979.96

Thank You For Working With Gallo Construction!



Gallo Construction Corp.
 50 Lincoln Avenue, Watervliet, NY 12189
 Phone 518.273.0234 Fax 518.273.0245

INVOICE

INVOICE : 21166-01
 DATE: February 15, 2022

FILE COPY

To : Town of Clifton Park
 639 Clifton Park Center Rd
 Clifton Park, NY 12065
 Attn: Accounts Payable

Job	PO	Sales Rep	Payment Terms	Due Date
21166	Contract	Mike Gallo	Net 30	3/15/2022

Date	AIA	Description	Total
2/28/2022	AIA 1	Clifton Park Highway Garage Awning	\$ 59,887.19
		Gross Invoice Amt: 63,0039.15	
		Less Retainage Amt: - 3,151.96	
		Net Invoice Due: 59,887.19	

Subtotal	\$ 59,887.19
Sales Tax	Exempt
Total	\$ 59,887.19

Thank You For Working With Gallo Construction!

FILE COPY

*Comptroller
SD
Ding*

Resolution No. 286 of 2021, a resolution authorizing Gallo Construction Corp of Watervliet, NY, to construct a permanent awning at the Highway Department.

Introduced by Councilwoman Walowit, who moved its adoption, seconded by Councilwoman Standaert.

WHEREAS, the Town Board and Highways Superintendent wish to construct a permanent awning at the Highway garage, and

WHEREAS, a notice to bid was published and sealed bids were received on December 1, 2021, pursuant to General Municipal Law Section 103(1), and

WHEREAS, Gallo Construction Corp, 50 Lincoln Ave., Watervliet, submitted the lowest responsive bid to construct the addition, in an amount not to exceed \$104,900, and

WHEREAS, there are sufficient funds in the assigned fund balance to complete the work as submitted; now, therefore, be it

RESOLVED, that Gallo Construction be awarded the bid and is authorized to construct a permanent awning as specified in the attached bid documents for the Highway Department, not to exceed \$104,900, to be paid with a transfer of funds from A-00914 (Undesignated Fund Balance) to A-05132-00200 (General Fund – Garage Highway – Equipment) with the possibility that funds from insurance proceeds are used to offset the total cost.

ROLL CALL VOTE

Ayes: Councilwoman Flood, Councilwoman Standaert, Councilman Morelli,
Councilwoman Walowit, Supervisor Barrett

Noes: None

DECLARED ADOPTED

December 13, 2021

Teresa Brobston, Town Clerk

HIGHWAY GARAGE AWNING BID 12/1/21 @ 3PM

COMPANY NAME	TOTAL BID AMOUNT
Bubona General Contr.	\$116,800-
Gallo Construction	104,900-



Gallo Construction Corp.
50 Lincoln Avenue, Watervliet, New York 12189
Phone (518) 273-0234 Fax (518) 273-0245

PROPOSAL

TO: Town of Clifton Park
RE: Clifton Park Highway Garage Awning
DATE: 12-1-21
SUBJECT: Highway Garage Awning

Thanks for the opportunity to provide a PROPOSAL for the above mentioned project.

We propose to furnish ALL labor, material, equipment, supervision, and other incidentals to complete all work as per plans & Specifications by Prime AE dated 11-12-21, drawings (A-2,B-1,B-2,B-3, C-1, C-2, D-1 & D-2).

Exclusions:

- 1) Mechanical work.
- 2) Removal of Hazardous Materials.

The Total Cost to Complete This Work Is \$ 104,900

We acknowledge receipt of the following Addendum: None

If you have any questions, please do not hesitate to contact me at my office. Again thanks for the opportunity, and look forward to work with you on this Project.

Respectfully,

Michael A Gallo

Michael A Gallo
Vice President

Electrical included

6 weeks Tosses

mike@gallogc.com



18 WEST ALBANY DRIVE ALBANY, NEW YORK 12205
TEL (518) 438-8900 FAX (518) 438-9193

December 01, 2021

Town of Clifton Park
One Town Hall Plaza
Clifton Park, New York 12065

Re: CP Highway Garage Awning

We respectfully submit our bid for the total cost of the CP Highway Garage Awning per your notice to bid and specifications provided by the Town Clerk's Office.

For the Total Price of \$ th 116,900.00

Feel free to call with any questions or revisions you may require.

General Conditions of this Offer

Unless expressly stated above, price(s) quoted are firm only if this offer is accepted within thirty (30) days of the above date and the work can be performed during the season ending 2022. The basis for the above prices is that this project is not subject to prevailing wages and that it is a Tax Exempt Project. If we do not receive a properly executed Tax Exemption Certificate, then all applicable sales taxes will be added to the quoted price(s). If the person(s), firm, corporation or entity accepting this offer is not the Owner of the real property being improved by the labor and/or materials provided for herein, the acceptor expressly warrants that the performance of the labor and/or the furnishing of the materials herein being done is for improvement of the real property with the consent of, or at the request of its owner, his agent, contractor or subcontractor. This offer and the performance of labor and the furnishing of any materials there under including prices quoted hereunder shall be subject to strikes, labor disputes, adverse weather conditions or other causes beyond the control of Bubonia Holding Corp. Payment in full is due upon completion of work.

BUBONIA HOLDING CORP.

BY: _____

Peter Zeltins - Project Manager

TOWN OF CLIFTON PARK
SARATOGA COUNTY, NEW YORK

NOTICE TO BID
CLIFTON PARK HIGHWAY GARAGE AWNING

PLEASE TAKE NOTICE: the Town of Clifton Park will receive sealed bids for a Clifton Park Highway Garage Awning. A Summary of Work will be available for pick-up in the Town Clerks Office, #1 Town Hall Plaza, Clifton Park, NY 12065, Monday-Friday, 9:00 AM-5:00 PM or by requesting electronic copies at tbrobston@cliftonpark.org or through the town website, www.cliftonpark.org Select Government, Select Requests for Bids and Proposals. Sealed bids, labeled "CP Highway Garage Awning", will be publicly opened on the 1st day of December 2021 at 3:00 PM at the Town of Clifton Park Town Hall, One Town Hall Plaza, Clifton Park, NY. Bids are due to the Town Clerk's Office before the bid opening. Bids must be made in writing in a manner that estimates the total cost of the project. The bid must be presented as a total cost and no change shall be made in the phraseology of the bid. Bids that carry any omissions, erasures, alteration or additions, may be rejected as informal. If you wish to make an appointment to view the work area, please contact the Clifton Park Highway Department at (518) 371-7310. Organizations submitting bids shall be authorized to do business in the State of New York. The Highway Superintendent reserves the right to reject any or all bids.

Teresa Brobston
Clifton Park Town Clerk

SECTION 01010
SUMMARY OF WORK

PART 1 - GENERAL

RELATED DOCUMENTS

Drawings & general provisions of Contract, including General & Supplementary Conditions & General Requirement & Special Requirement Specification sections, apply to work of this section.

PROJECT/WORK IDENTIFICATION

Project Name is *Town of Clifton Park Highway Garage Awning*, as shown on Contract Documents prepared by PRIME AE Group of NY, 100 Great Oaks Boulevard, Suite 114 Albany, NY 12203.

Contract Documents indicate work of Contract & related requirements & conditions that impact the project. Related requirements & conditions that are indicated on Contract Documents include, but are not necessarily limited to the following: Existing site conditions & restrictions on use of site.

Summary of Work: The proposed project will consist of furnishing all materials, equipment and labor necessary for the installation of an awning roof structure at the Town of Clifton Park Highway Garage off of Clifton Park Center Road. Work of this Contract, as defined in greater detail by other provisions of Contract Documents, is summarized as follows:

1. A building permit will be required for this work and must be obtained by the Contractor through the Town of Clifton Park Building Department. Provide the plans included in the Contract Documents to the Town of Clifton Park Building Department when applying for the building permit.
2. Provide all necessary survey, stakeout, and layout required to construct the work of this Contract.
3. Contractor shall layout truss configuration in field prior to ordering. Advise Engineer of any conflicts found with existing building exterior or existing building eaves should any such conflicts be identified.
4. Provide maintenance and protection of traffic.
5. Furnish and install temporary erosion and dust control methods throughout the duration of the project as necessary to protect the environment and to limit disturbances caused by work of this Contract.
6. Furnish all materials necessary, and install new awning roofing system including all excavation, foundation footings, rebar, backfill, wooden columns, steel girder beams, roof trusses, sheathing, ice underlayment, metal roof panels, soffit, and fascia, as shown and specified.
7. Furnish and install flashing between existing wall and proposed awning roof structure to provide a single watertight roof, as shown and specified.
8. Furnish and install bird screen underneath trusses and on sides of end trusses, as shown and specified.
9. Furnish and install light fixtures, including all conduit, conduit supports, wire, light switch, circuit breaker in existing power panel, and all required penetrations as shown and specified.
10. Contractor is responsible for relocation of any existing exterior building items that create a conflict with the new awning, including but not limited to, light fixtures and vent piping. Any vent piping to be relocated shall be routed up through the awning roof and sealed and flashed per the metal roof panel manufacturer's recommendations.
11. Clean up and dispose of all debris resulting from this contract in a legal manner.
12. Coordinate all work with Town Highway Department operations to limit disruption caused by work under this contract.

13. Restore all areas disturbed by this contract to the Owners satisfaction and as specified herein.
14. Provide temporary facilities as required to perform work under this contract.
15. Provide protection of persons and property from hazards associated with this work.
16. Provide quality control testing required for materials incorporated into this project.

EXTENT OF WORK

Definition of extent of Contract Work: Extent of work is indicated in Contract Documents. Local custom & trade-union jurisdictional settlements do not control scope-of-work in this Contract. When a potential jurisdictional dispute or similar potential work interruption is first identified or threatened, affected parties of Contract shall promptly negotiate a reasonable settlement which will avoid or minimize such pending interruption & its delays or losses.

Summary by Reference: Work can be summarized by reference to Contract, General Conditions, Supplementary Conditions, Specification sections, Drawings, Addenda & Modifications to Contract Documents issued subsequent to initial printing of this Project Manual, & including but not necessarily limited to printed material referenced by any of these. It is recognized that work of Contract is unavoidably affected or influenced by governing regulations, natural phenomenon, including weather conditions & other forces outside contract documents.

In cases of discrepancy between Contract Drawings & Contract Specifications, interpretations shall be given preference in the following order:

1. Addenda (later dates take precedence).
2. Technical Specification
3. Supplementary Conditions
4. General Condition.
5. Contract Drawings (Schedules or Notes to take precedence over other data shown on aforesaid drawings.)

CONTRACTOR'S USE OF PREMISES

General: CONTRACTOR shall limit use of premises to Work indicated, so as to allow for public access where appropriate.

Use of Site: Confine operations at site to areas permitted under Contract. Portions of site beyond areas on which work is indicated are not to be disturbed.

Do not unreasonably encumber site with materials or equipment.

Work accomplished under this Contract shall progress in such a manner as to keep any & all inconveniences to a minimum. Construction work shall further be planned, scheduled & accomplished to minimize interruptions of municipal services and to both vehicular and pedestrian traffic in the project area.

OWNER Occupancy: Cooperate with OWNER during construction operations to minimize interruption of services to OWNER. Any interruption of service is to be planned, scheduled & approved by OWNER.

A detailed schedule will be required to be submitted within 48 hours of the bid opening by the apparent low bidder, that will show a detailed plan and schedule, including manpower equipment, and general approach for completing the work. Failure to provide an acceptable plan could result in rejection of the low bid.

**TOWN OF CLIFTON PARK
HIGHWAY GARAGE AWNING**

PART 2 - PRODUCTS

(Not Applicable)

PART 3 - EXECUTION

(Not Applicable)

TOWN OF CLIFTON PARK HIGHWAY GARAGE AWNING

TOWN BOARD

Philip Barrett - Town Supervisor	Council Member
Lynda Walowit	Council Member
Anthony Morelli	Council Member
Amy Standaert	Council Member
Amy Flood	Council Member
Teresa J. Brobston	Town Clerk
Dahn S. Bull	Superintendent of Highways



Albany Office
100 Great Oaks Blvd., Suite 114 Albany, New York 12203
Ph: 518 382.1774 www.primeng.com

BID ISSUE: NOVEMBER 12, 2021

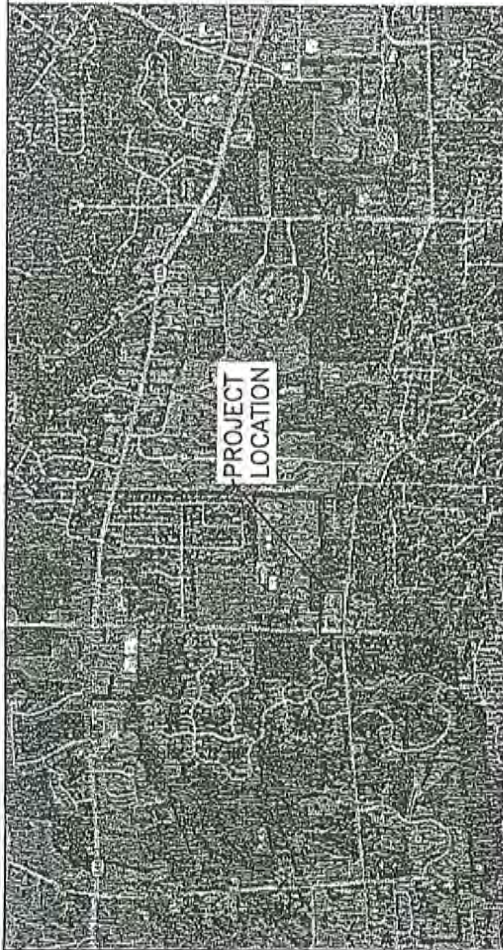

A PROJECT LOCATION MAP
A2 NOT TO SCALE

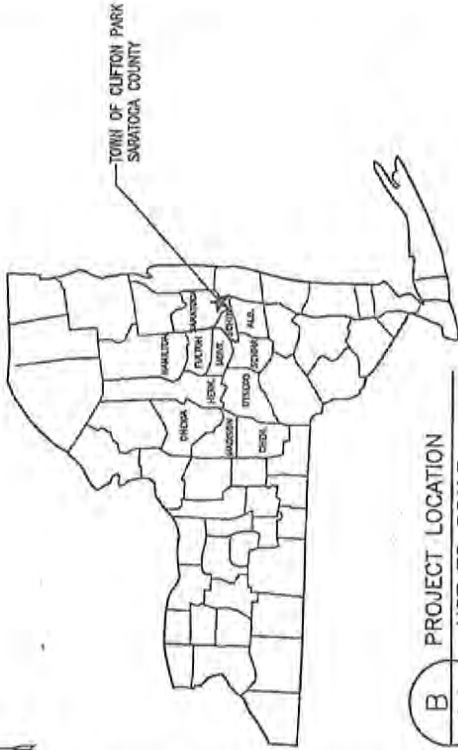

B PROJECT LOCATION
A2 NOT TO SCALE

GENERAL CONTRACT DRAWING NOTES:

- PROJECT SITE PLANS ARE BASED ON MAPPING PROVIDED BY THE TOWN OF CLIFTON PARK AND SURVEYS BY PRIME AS GROUP OF NY.
- CONTRACTOR MUST COORDINATE WORK WITH HIGHWAY DEPARTMENT AND MINIMIZE INCONVENIENCES. CONTRACTOR IS TO TAKE MEASURES TO PROTECT SYSTEMS FROM DAMAGE DUE TO WORK OF THIS PROJECT.
- CONTRACTOR SHALL BE RESPONSIBLE FOR REPAIR OF ANY DAMAGE TO HIGHWAY DEPARTMENT PROPERTY RESULTING FROM THE CONTRACTORS WORK AT NO COST TO THE OWNER.
- CONTRACTOR SHALL CONTACT DIG SAFELY NEW YORK PRIOR TO COMMENCING WORK TO DETERMINE THE LOCATIONS OF UNDERGROUND UTILITIES. EXISTING UTILITIES MAY BE SHOWN IN THEIR RELATIVE POSITIONS AND ARE FOR INFORMATION ONLY. CONTRACTOR SHALL BE RESPONSIBLE FOR REPAIR OF ANY DAMAGES TO FACILITIES RESULTING FROM THE CONTRACTOR'S WORK, AT NO COST TO THE OWNER.
- ALL PRECAUTIONS SHALL BE TAKEN TO PROTECT THE ENVIRONMENT IN ACCORDANCE WITH THE STATE, FEDERAL AND LOCAL REGULATIONS AND AS SPECIFIED IN THE CONTRACT DOCUMENTS.
- CONTRACTOR SHALL RESTORE ALL LAWN, DRIVEWAYS, ROADS, SHOULDERS, FENCES, ETC. TO A CONDITION AT LEAST AS GOOD AS THEY WERE PRIOR TO CONSTRUCTION. DAMAGE SHALL BE REPAIRED AT CONTRACTOR'S EXPENSE.
- NO WORK, STORAGE OR TRESPASS SHALL BE PERMITTED BEYOND THE BOUNDARIES OF THE OWNER'S EASEMENTS OR PROPERTY.
- CONTRACTOR IS RESPONSIBLE FOR ALL TRAFFIC CONTROL, DUST CONTROL, AND PROTECTION OF PUBLIC FROM HAZARDS ASSOCIATED WITH THIS WORK DURING WORKING AND NON-WORKING HOURS.
- CONTRACTOR SHALL SUPPORT ALL UTILITIES AND STRUCTURES WHERE NECESSARY DUE TO THE WORK OF THIS CONTRACT.
- EXTENT OF WORK IS INDICATED ON THE CONTRACT DRAWINGS AND SPECIFICATIONS. EACH CONTRACTOR IS RESPONSIBLE FOR REVIEW OF EXTENT OF WORK BY OTHERS AND COORDINATE THEIR OWN WORK WITH WORK BY OTHER CONTRACTORS.

SHEET #	TITLE	REFERENCE NO.
A1	COVER	21492-000
A2	INDEX & PROJECT LOCATION	21492-010
B1	SITE PLAN	21492-100
B2	FLOOR PLAN	21492-110
B3	EAST & WEST ELEVATIONS	21492-120
C1	FOOTING DETAIL	21492-200
C2	ROOF DETAILS	21492-210
D1	ELECTRICAL DETAILS	21492-300
D2	LIGHTING PLAN	21492-310

NO.	DATE	BY	REVISION

PRIME
100 BUCK CREEK DR | SUITE 114 | CLIFTON, NY 12025
PH: 518.282.3774 WWW.PRIMECONTRACTORS.COM

PRIME CONTRACTORS
A MEMBER OF THE PRIME GROUP

PRIME GROUP, INC.
CLIFTON, NY 12025

TOWN OF CLIFTON PARK
SARATOGA COUNTY, NY

HIGHWAY GARAGE AWNING

INDEX & PROJECT LOCATION

SCALE: AS SHOWN
FILE NO.: 21492-019
DATE: NOVEMBER 2023

SHEET NO.: A2

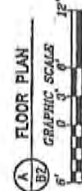
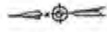
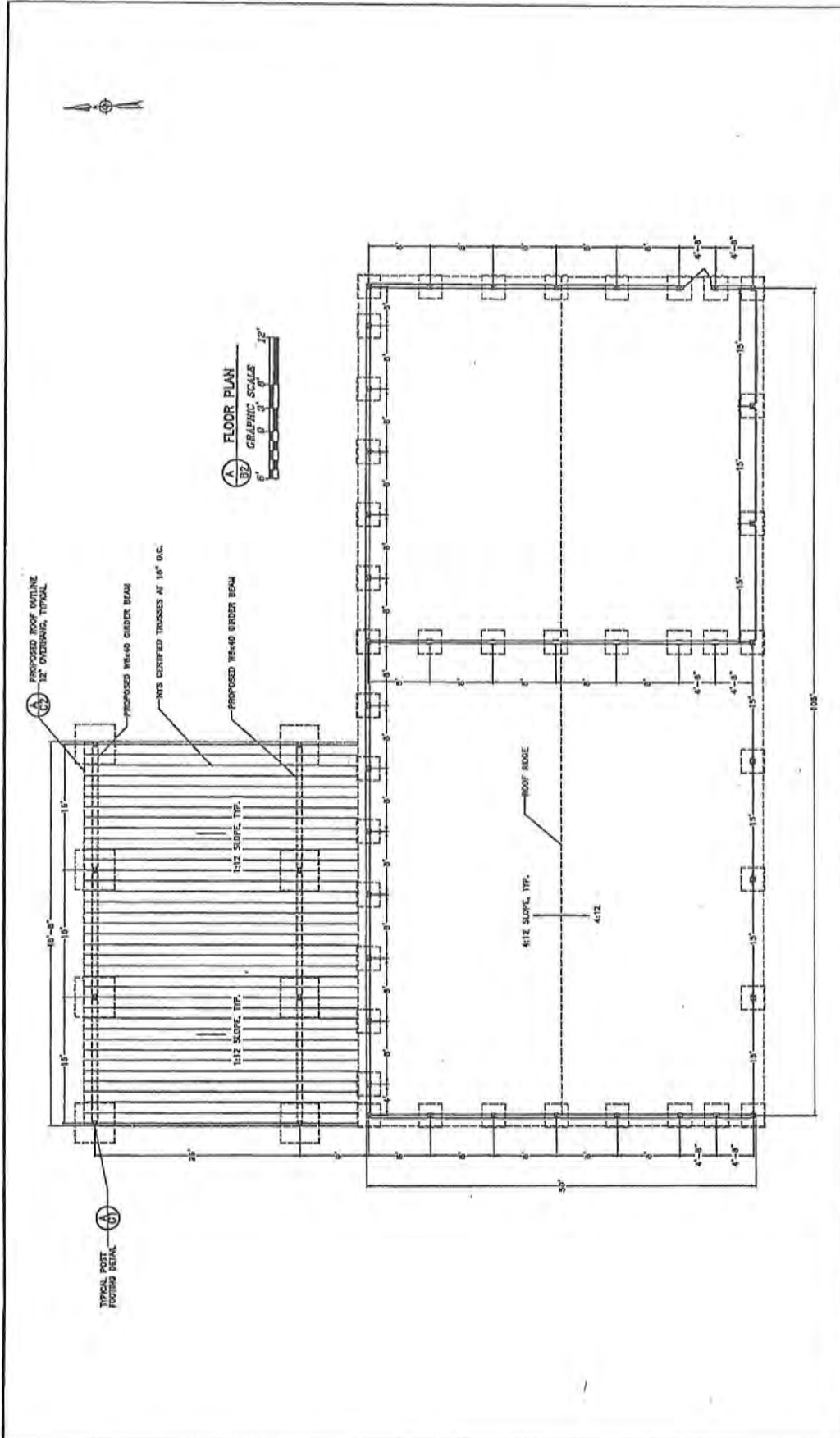

SCALE:	AS SHOWN
FILE NO.:	21493-110
DATE:	NOVEMBER 2021

SHEET NO.: B2

SHEET TITLE: FLOOR PLAN

TOWN OF CLIFTON PARK
SARASOTA COUNTY, FL

HIGHWAY GARAGE AWNING



PRIMER
180 Gulf Coast Blvd E, Suite 111 | Albany, GA 31707
Tel: 318.361.1774 | www.primer.com

MAIL: 800.441.854 DRAWN BY: JCS CHECKED BY: JST

NO.	DATE	REVISION	BY
1	11/12/2021	ISSUE FOR PERMIT	JCS
2	11/12/2021	ISSUE FOR PERMIT	JCS

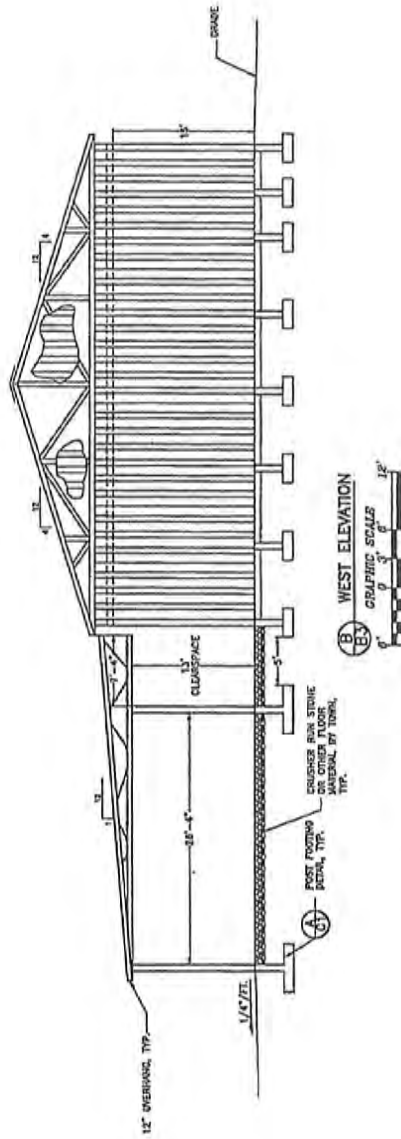
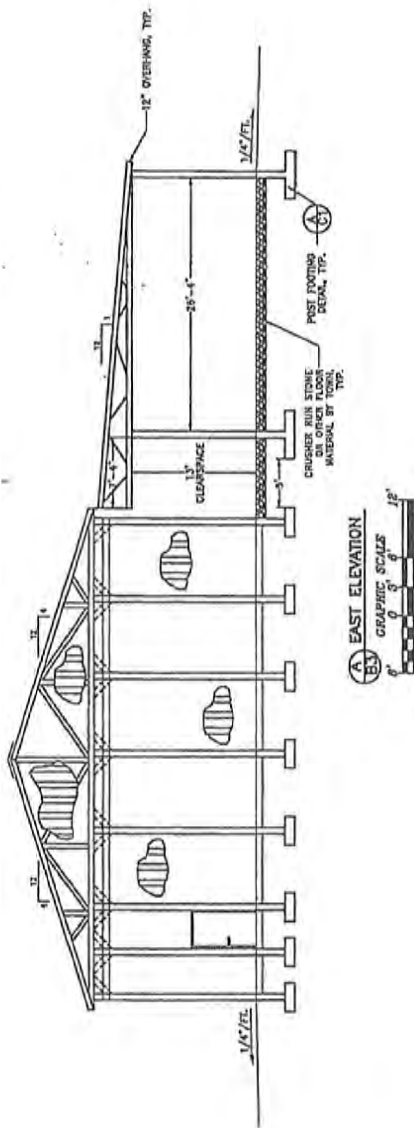

SCALE: AS SHOWN
 FILE NO.: 21492-330
 DATE: NOVEMBER 2011

SHEET TITLE:
 EAST & WEST ELEVATIONS

TOWN OF COUTON PARK
 SARATOGA COUNTY, NY
 HIGHWAY GARAGE AWNING



PRIMEC
 ARCHITECTS
 189 Great Oaks Blvd I-684 Exit 164 Albany, New York 12203
 Ph: 518 242 2724 www.primec.com

NO.	DATE	REVISION	BY
01	11/29/11	ORIGINAL ISSUE	ASJ
02	11/29/11	END ISSUE	ASJ

PROJECT NO.: 214
 DRAWN BY: ASJ
 CHECKED BY: JPT

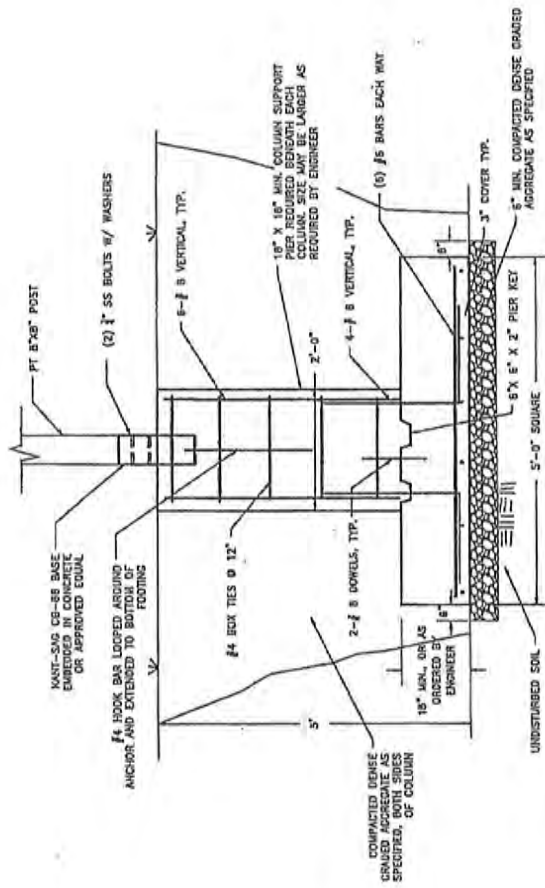

A C1 COLUMN PIER DETAIL
NOT TO SCALE

SCALE:	AS SHOWN
FILE NO.:	31492-200
DATE:	NOVEMBER 2021

SHEET TITLE:
FOOTING DETAIL

TOWN OF CLIFTON PARK
SARASOTA COUNTY, FL
HIGHWAY GARAGE AWNING



PRIME
PROFESSIONAL ENGINEERING & ARCHITECTURE, L.L.C.

100 East Oak Ridge Road (M) Palmyra, New York 12453
Ph: 518 243 1774 www.primeeng.com

PROJECT: HIGHWAY GARAGE AWNING
DRAWN BY: JMS
CHECKED BY: JMT

NO.	DATE	REVISION
01		ORIGINAL ISSUE
02		REVISED
03		REVISED

SHEET NO.: **C1**

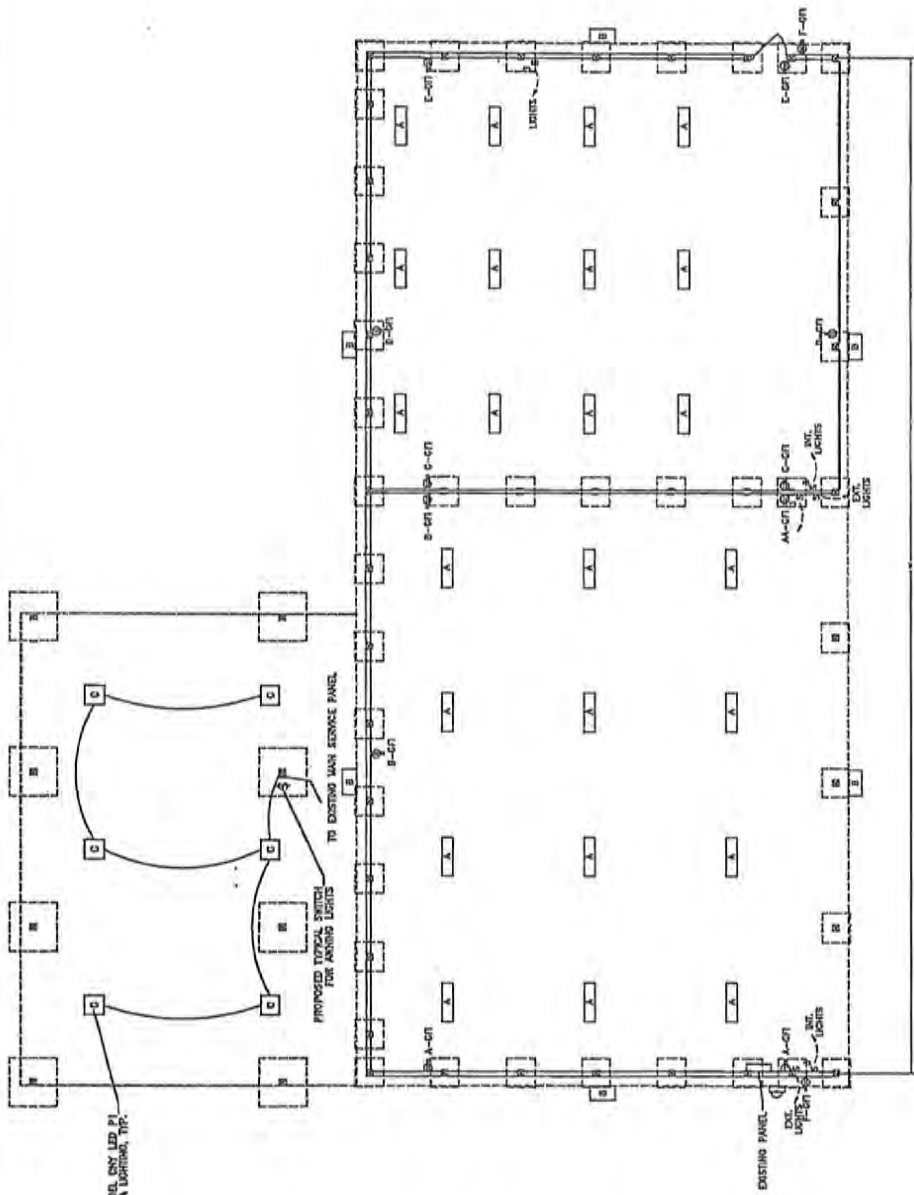
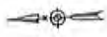

LIGHTING PLAN
 GRAPHIC SCALE

SCALE: AS SHOWN
 FILE NO.: 21492-310
 DATE: NOVEMBER 2021
 SHEET NO.: D2

SHEET TITLE:
LIGHTING PLAN

HIGHWAY GARAGE AWNING
 TOWN OF CLIFTON PARK
 SARATOGA COUNTY, NY



PRIME
 100 South Oaks Blvd | Suite 1101 | Babylon, New York 11703
 PH: 516 232 1774 | www.primeawing.com
 PROJECT NO.: 2021-001
 CHECKED BY: JST

NO.	DATE	REVISION	BY
01	11/23/2021	ORIGINAL ISSUE	JST
02		REVISED	JST

HWY
Comptroller
SD

Resolution No. 225 of 2021, a resolution to retain Prime AE Group of NY for professional engineering services related to the immediate storage needs of the Clifton Park Highway Department.

Introduced by Councilwoman Standaert, who moved its adoption, seconded by Councilwoman Flood.

WHEREAS, on August 17, 2021, the Clifton Park Highway had an accidental fire that caused severe damage to the facility known locally as "The White Building", and

WHEREAS, "The White Building" housed various pieces of equipment and machinery, as well as 7 bays for plow trucks over the winter months, and

WHEREAS, as a result, there is an immediate need to design and construct temporary structures in order to provide cover and protection from the elements to Highway Department plow trucks and related equipment, and

WHEREAS, Prime AE Group of NY, will produce a scope of work and oversee the construction of structures that will protect plow trucks and equipment from winter weather, and

WHEREAS, pursuant to Resolution No. 1 of 2021, the town is authorized to enter into a contract with an engineering or professional consulting firm, subject to legal review by the Town Attorney's office, and

WHEREAS, the Prime AE Group estimates that design and engineering services for the structures will not exceed \$20,000; now, therefore, be it

RESOLVED, that the Town Board authorizes the hiring of Prime AE Group of New York to assist the Highway Department in planning and design of structures for the Highway Department for the 2021-22 winter season, and be it further

RESOLVED, that the Town Superintendent of Highways is authorized to sign an agreement with Prime AE Group of NY for professional consulting services not to exceed \$20,000; and be it further

RESOLVED, that the Comptroller is authorized to transfer \$20,000 from A-00915 (Undesignated Fund Balance) to A-5132-135 (General Fund - Highway Garage - Engineering).

ROLL CALL VOTE

Ayes: Councilwoman Flood, Councilwoman Standaert, Councilman Morelli,
Councilwoman Walowit, Supervisor Barrett
Noes: None

DECLARED ADOPTED

September 20, 2021

Teresa Brobston, Town Clerk

RESOLUTION
#2

Resolution No. _____ of 2022. a resolution authorizing the purchase of a Tiger Bengal Brute/ Brute-LRS Mower for the Highway department from Trius Inc. pursuant to Sourcewell Contract #070821.

Introduced by _____, who moved its adoption, seconded by _____.

WHEREAS, Highway Superintendent Dahn Bull has requested authorization to purchase a new Tiger Bengal Brute/Brute-LRS Mower from Tiger Mowers, (Trius Inc. of Fort Edward, NY), pursuant to a competitive procurement process through the Sourcewell Contract Cooperative, for use by the Highway Department, and

WHEREAS, pursuant to General Municipal Law §103(16), municipalities are authorized to purchase materials, equipment or supplies through publicly bid contracts of another political state, or political subdivision thereof, and

WHEREAS, Sourcewell is a service cooperative created under Minnesota Statute §123A.21, and provides cooperative purchasing contracts under Minnesota Statute 471.59 to participating agencies and governments, and

WHEREAS, Mr. Bull advises the Boom mower available through Sourcewell Contract #070821 will best meet the needs of the department; now, therefore, be it

RESOLVED, that the Highway Department is authorized to purchase the Tiger Bengal Brute/Brute-LRS Mower referenced above from Trius Inc., in an amount not to exceed \$163,244.10, from line DA-5130-219, Vehicle Equipment.

Resolution No. _____ of 2022, a resolution authorizing the purchase of a Tiger Bengal Brute/ Brute-LRS Mower for the Highway department from Tiger Mowers pursuant to Sourcewell Contract #070821.

Introduced By Council _____, who moved its adoption, seconded by Council

WHEREAS, Highway Superintendent Dahn Bull has requested authorization to purchase a new Tiger Bengal Brute/Brute-LRS Mower from Tiger Mowers, pursuant to a competitive procurement process through the Sourcewell Contract Cooperative, for use by the Highway Department, and

WHEREAS, pursuant to General Municipal Law §103(16), municipalities are authorized to purchase materials, equipment or supplies through publicly bid contracts of another political state or political subdivision thereof, and

WHEREAS, Sourcewell is a service cooperative created under Minnesota Statue §123A.21, and provides cooperative purchasing contracts to public entities under Minnesota Statue 471.59 to participating agencies and governments, and

WHEREAS, Mr. Bull advises the Boom mower is available through Sourcewell Contract #070821, will best meet the needs of the department, now therefore, be it

RESOLVED, that the Highway Department is authorized to purchase the Tiger Bengal Brute/Brute-LRS Mower referenced above from Trius Inc. of Fort Edward, NY, in an amount not to exceed \$163,244.10, from line DA-5130-219, Vehicle Equipment.

ROLL CALL VOTE

Ayes:

Noes:

Meg Springli

From: noreply
Sent: Tuesday, October 4, 2022 10:30 AM
To: Meg Springli
Cc: Jean, Spiegel; Mark Heggen; Tom McCarthy
Subject: Resolution Request for TB Meeting: 10-11-2022 Highway Department
Attachments: 633c438042602-Sourcewell Purchase Example - Sewer Department.pdf; 633c438043337-Backup for Purchase of Boom Mower Part 1.pdf; 633c438044ae1-Backup for Purchase of Boom Mower Part 2.pdf

An item has been submitted to the Resolution Request form for review.

Department: **Highway Department**
Your email: **dbull@cliftonpark.org**

Sponsor/Contact as shown on the agenda (i.e. P. Barrett, A. Standaert, D. Bull, etc.): **D. Bull**

Requested Meeting Date: **10-11-2022**

Brief Description: **This request is to replace our current mid-mount boom mower that is aging out. We are piggybacking off of a sourcewell contract, #070821.**

Budget #: **DA-5130-219**
Budget Description: **Vehicle/Equipment**
\$ Amount: **\$163,244.10**

Additional Comments/Details: **The equipment has a propriety manufactured safety mechanism that allows for the rotary head to swivel and pivot under certain straining conditions, protecting it from damaging materials hiding in the grass.**

COMPTROLLER APPROVAL or Comments:

ATTORNEY APPROVAL or Comments:

ROLL CALL VOTE

Ayes: Councilwoman Flood, Councilwoman Standaert, Councilman Morelli,
Councilwoman Walowit, Supervisor Barrett

Noes: None

DECLARED ADOPTED

Resolution No. 84 of 2021, a resolution authorizing the purchase of a newly built Vector Impact Sewer Cleaner/Vacuum Truck for the Sewer Department from Joe Johnson Equipment pursuant to Sourcewell Contract.

Introduced by Councilwoman Standaert, who moved its adoption, seconded by Councilwoman Walowit.

WHEREAS, Collection System Manager Michael O'Brien, has requested authorization to purchase a new dual-purpose sewer cleaner and vacuum truck from Joe Johnson Equipment, pursuant to a competitive procurement process through the Sourcewell Service Cooperative, for use by the Sewer Department, and

WHEREAS, pursuant to General Municipal Law §103(16), municipalities are authorized to purchase materials, equipment or supplies through publicly bid contracts of another political state or political subdivision thereof, and

WHEREAS, Sourcewell is a service cooperative created under Minnesota Statute §123A.21, and provides cooperative purchasing contracts to public entities under Minnesota Statute 471.59 to participating agencies and governments, and

WHEREAS, the Comptroller has solicited bids authorized by Resolution No. 50 of 2021, for a municipal lease to pay for the sewer vacuum truck, and

WHEREAS, Mr. O'Brien advises that the Vector combination single engine sewer cleaner and vacuum truck available through Sourcewell Contract # 122017, issued following a Request for Proposal using best value criteria, will best meet the needs of the department and provide cost-effective dual-purpose capacity for the department; now, therefore, be it

RESOLVED, that the Sewer Department is authorized to purchase the Vector Cleaner/Vacuum Truck referenced above, in an amount not to exceed \$286,810 to be through a municipal lease to be bid and authorized separately; and be it further

RESOLVED, the Town Supervisor is authorized to enter into a lease purchase to purchase the sewer vacuum truck over a 7-year period.

ROLL CALL VOTE

Ayes: Councilwoman Flood, Councilwoman Standaert, Councilman Morelli,
Councilwoman Walowit, Supervisor Barrett

Noes: None

DECLARED ADOPTED

Collection System Manager Michael O'Brien gave an update on the Oakwood Blvd. project. The project consisted of replacing 900' of 8" sewer line and numerous laterals and manholes. He stated the project is complete and under budget. The Highway Department will be assisting with the paving of the whole area.

Resolution No. 85 of 2021, a resolution authorizing the Supervisor to sign a lease agreement with Key Government Financing, Inc., for leasing of General Fund and Highway Fund vehicles.

 **TIGER**™
ROTARY AND FLAIL
Boom
Mowers



Bengal Brute

Bengal Brute standard with secondary boom breakaway. Available with LRS on specific tractor models.

DURABILITY INNOVATION
COMMITMENT



Bengal 18-22-24

18'



22'



High mount
Extreme Duty
boom swivel bracket
All Bengals

24'

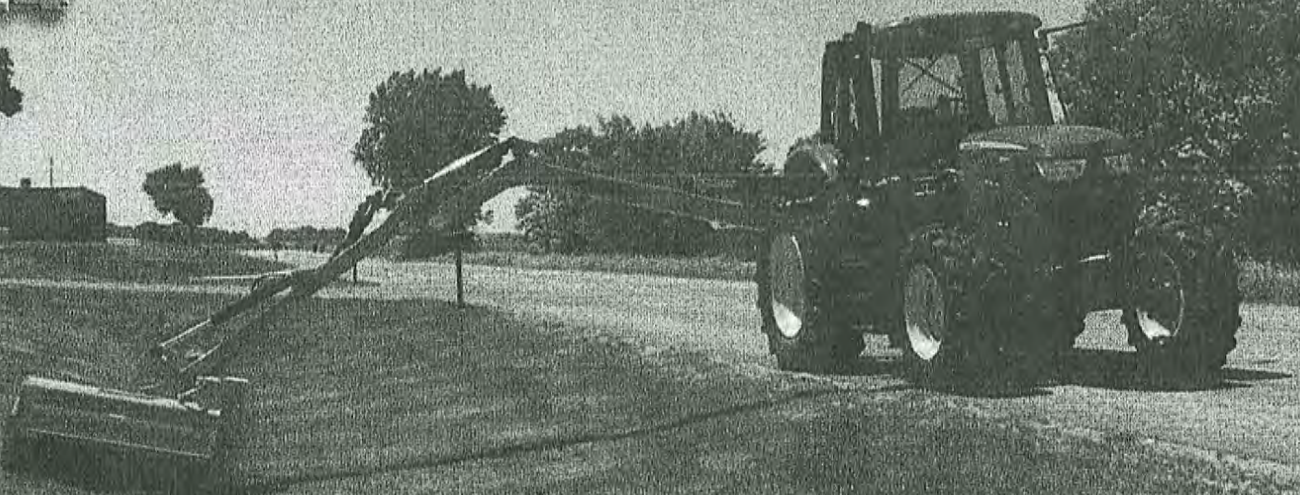



Rotary heads



50" Rotary

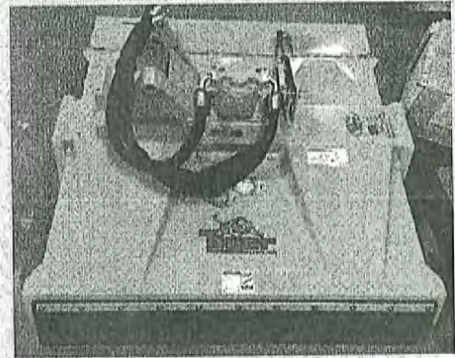

60" Rotary

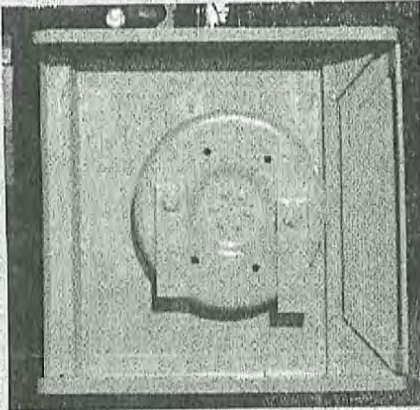

Cuts Up to 6" brush

50" or 60" Bengal Rotary heads have the choice of Disc or Blade bar cutting systems.

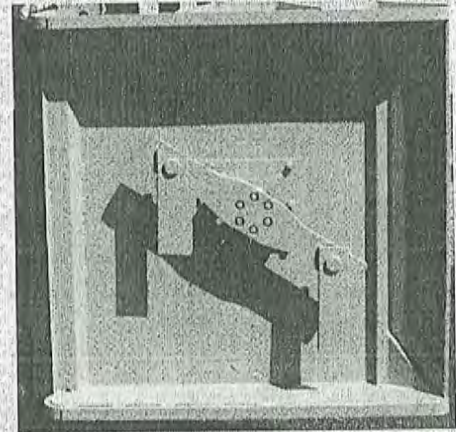

Cuts Up to 5" brush

Flail heads

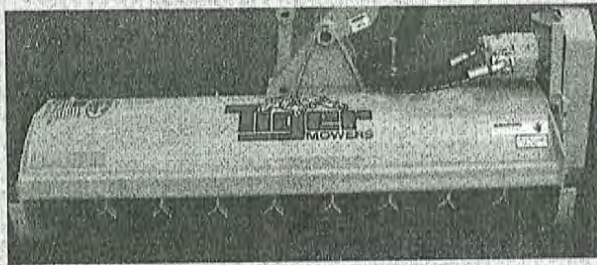

63" Flail with Grass knives

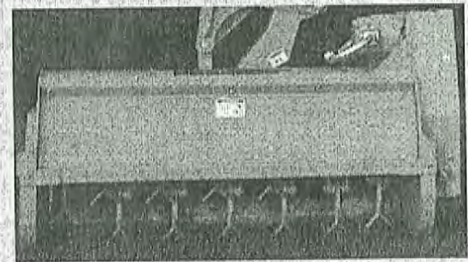

50" Flail with MBG knives

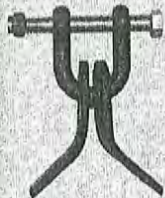

Grass
Grass only



LBG
Up to 2 1/2" brush

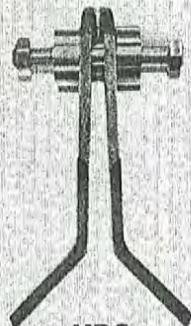

MBG
Up to 3" brush



HDB
Up to 4" brush

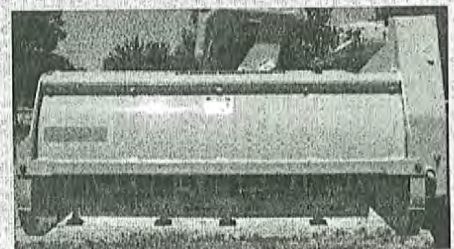

50" Flail with HDB knives



Stow Systems



SIDE STOW (SS)



SINGLE PT STOW (10S)



**3 PT OPEN STOW (30S)
W/ DBL AXLE SUPPORT**



**BENGAL BRUTE STOW
W/ SECONDARY BOOM
BREAKAWAY**



Modular Frame

Wheel well
hydraulic reservoir

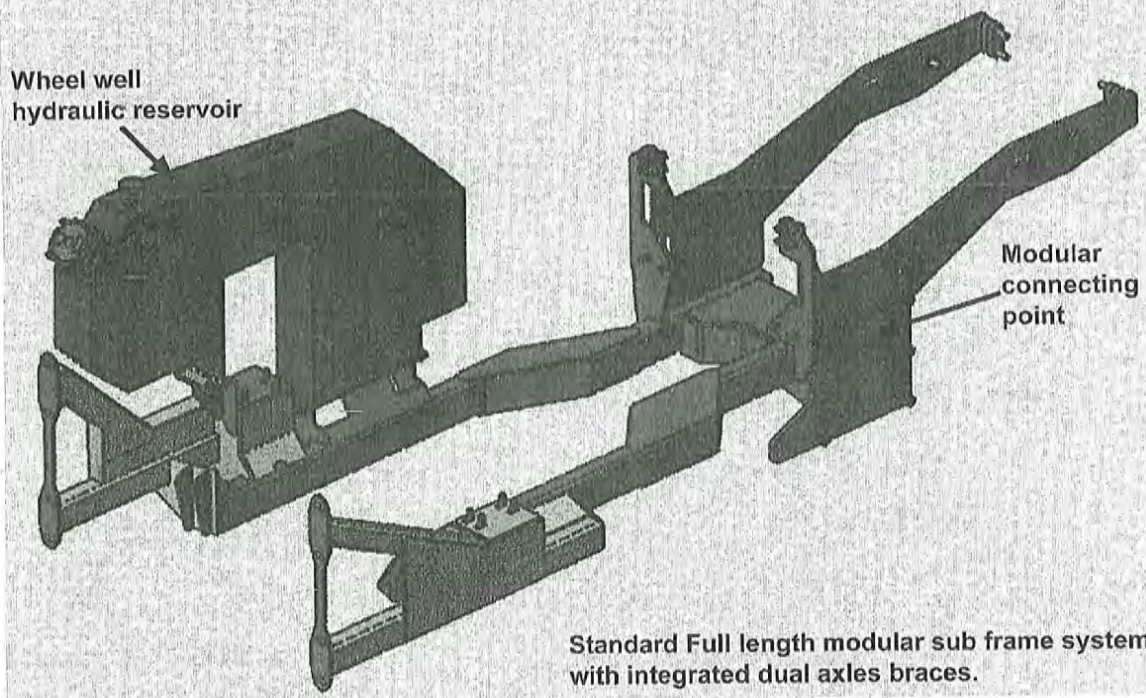

Modular
connecting
point

Standard Full length modular sub frame system
with integrated dual axles braces.

Tiger has redesigned the mounting frame for several of our tractor assemblies in a new modular format. This unique design builds additional strength into the tractor framing system while providing interchangeability. With a Tiger modular frame, changing from a boom to a side mower or from a side to a boom can be done in as little as eight hours. This increases flexibility of use without the need to buy a complete new frame and mowing system.

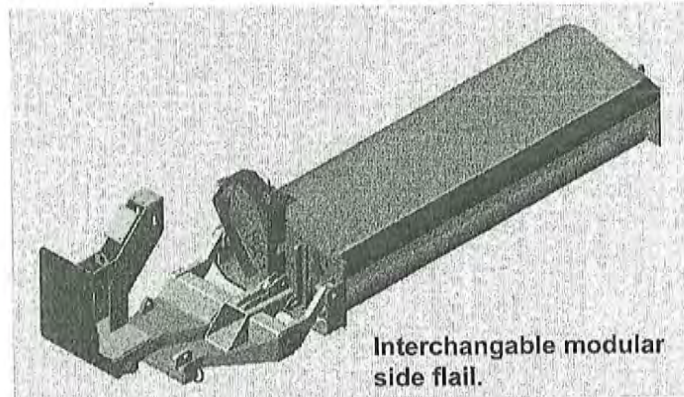

Interchangeable modular
side flail.



Interchangeable modular
boom arm.

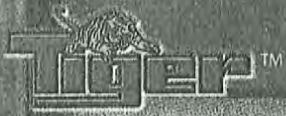

Modular Frame

Wheel well
hydraulic reservoir

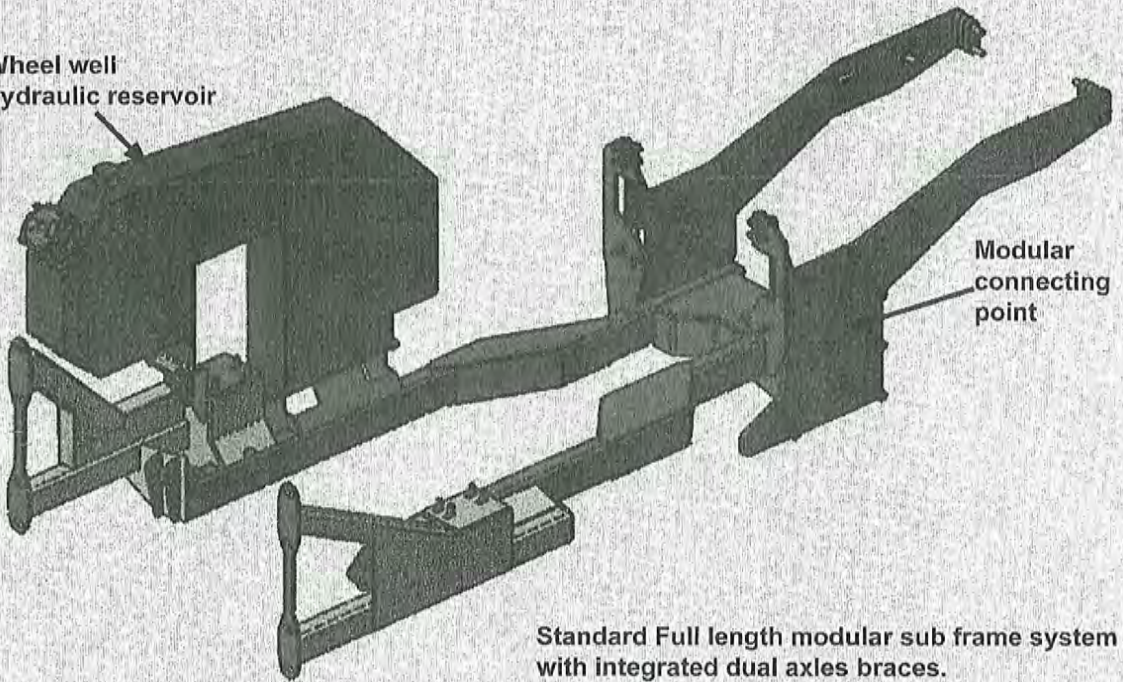

Standard Full length modular sub frame system
with integrated dual axles braces.

Tiger has redesigned the mounting frame for several of our tractor assemblies in a new modular format. This unique design builds additional strength into the tractor framing system while providing interchangeability. With a Tiger modular frame, changing from a boom to a side mower or from a side to a boom can be done in as little as eight hours. This increases flexibility of use without the need to buy a complete new frame and mowing system.

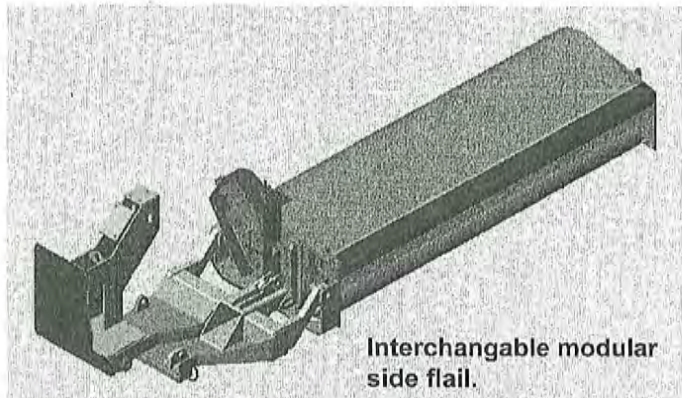

Tiger™

Saber

25·28·30

25'



28'

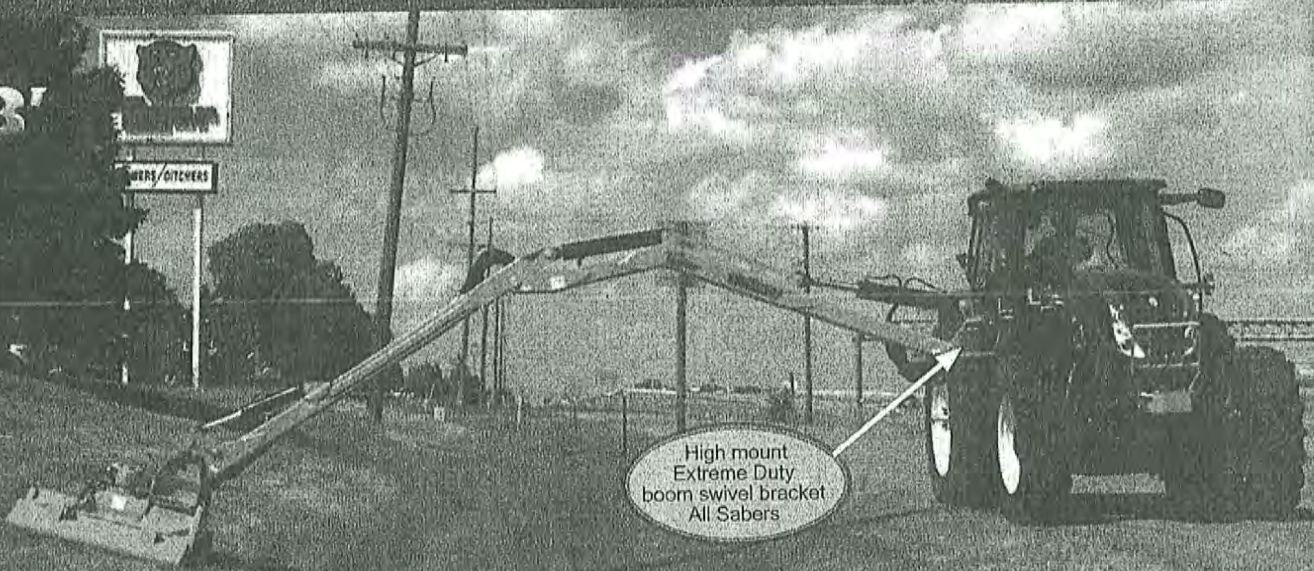

30'



Bill To:	Town Of Clifton Park, NY		
Ship to:	Trius Inc. - Fort Edward, NY		
End User:	Town Of Clifton Park, NY		
End User Contact:		PO#:	
Quote#:	PRH 9/1/22	Order Date:	
Dealer Contact:	Tark Croteau	Quote Date:	09/01/22
DLR Phone / Fax:		Requested ship date:	
Dealer Email:		State contract order:	070821-TGR
		Sourcewell Member #:	
		Quote valid for 30 days:	



Please direct questions to:

Ph: 800-843-6849 EXT 3
email all quotes in excel format
to:orders@tigermowers.com

BENGAL BRUTE & BENGAL BRUTE-LRS

(Boom Reach from 21.6' to 24.3')

HOW TO ORDER: You must select one item from Sections 1, 2 & 3 for a complete Boom Mower.

Qty	Order Code	Description	Approx. (lbs)	List Price	Disc	Sourcewell Price
Add tractor on next line when required						
1	610SE Standard	Cab MFWD 24F x 12R Power Reverser, Wet Clutch	9575	\$ 99,780	18%	\$ 81,819.60
SECTION 1 - Choose a Base Unit						
1	Brute - LRS	Mid-mount Boom Mower w/ LEGAL REAR STOW (LRS) transport system & 1700 lbs Wheel Weight	4525	\$ 52,265	18%	\$ 42,857.30
		INCLUDES: Boom Arms, Mounting system, Wheel Weights, Mower Hydraulic Drive System, Stow system, Travel Safety Lock, Operator Safety Screen/Poly				
	Brute - STD	Mid-mount Boom Mower w/ breakaway secondary boom arm,(3CS) transport system & 1700 lbs Wheel Weight	4525	\$ 52,265	18%	\$ -
		INCLUDES: Boom Arms, Mounting system, Wheel Weights, Mower Hydraulic Drive System, Stow system, Travel Safety Lock, Operator Safety Screen/Poly				
	Boom Rest - EXT	Extended Boomrest	22	\$ 637	18%	\$ -
SECTION 2 - Choose a Cutter Head						
ROTARY - LRS ONLY						
1	RT50D-LRS	50" Rotary Head -Disk/Brush Knives & Hydraulic Door	815	\$ 16,506	18%	\$ 13,534.92
	RT50B-LRS	50" Rotary Head - Blade Bar/Brush Knives & Hydraulic Door	740	\$ 16,330	18%	\$ -
	RT50G-LRS	50" Rotary head - Disk/Grass Knives & Hydraulic Door	815	\$ 16,459	18%	\$ -
	RT60B-LRS	60" Rotary Head - Blade Bar/Brush Knives & Hydraulic Door	840	\$ 19,156	18%	\$ -
	RT60DG	60" Rotary Head - Disk/Grass Knives & Hydraulic Door	915	\$ 19,195	18%	\$ -
FLAIL - LRS ONLY						
	FL50DBG-LRS	50" Flail Head with Light Brush/Grass Knives	800	\$ 19,027	18%	\$ -
	FL50MBG-LRS	50" Flail Head with Medium Brush/Grass Knives	808	\$ 20,009	18%	\$ -
	FL50HDB-LRS	50" Flail Head with Heavy Duty Brush Knives	815	\$ 20,062	18%	\$ -
	FL63G-LRS	63" Flail Head with Grass Knives	855	\$ 19,374	18%	\$ -
MULCHER - LRS ONLY						
	ML36-LRSCHN	36" Mulcher Head with Quad Cut Teeth - Rear Chain	925	\$ 25,023	18%	\$ -
	ML36-LRSRUB	36" Mulcher Head with Quad Cut Teeth - Rear Rubber Flap	925	\$ 24,084	18%	\$ -
SECTION 3 - Choose a Hydraulic Controls Options						
1	CBL	Cable Controls and Lift Valve Kit	78	\$ 6,931	18%	\$ -
	JSTK	Joystick, Electro-hydraulic and Valve Kit	80	\$ 17,432	18%	\$ 14,294.24
SECTION 4 - Installation Charge						
1	Factory Mnt	Installation of complete boom mower system		\$ 8,461	18%	\$ 6,938.02
	Field Mnt	Installation of complete boom mower system		\$ 8,461	18%	\$ -
SECTION 5 - BOOM MOWER OPTIONS						
		Wheel Weight - upcharge to 2550 lbs of counter balance.	850	\$ 2,699	18%	\$ -
	AXSTAB HYD	Cylinder Axle Stabilizer Kit - Verify tractor model	55	\$ 1,787	18%	\$ -
	AXSTAB TIMBREN	Timbren Axle Stabilizer Kit - Verify Tractor Model	25	\$ 555	18%	\$ -
	06100615	Dogleg Kit, Flail Heads	13	\$ 603	18%	\$ -
	06103017	Dogleg Kit, Rotary & Mulcher Heads	13	\$ 603	18%	\$ -
	P GUARD	Pump Guard	28	\$ 305	18%	\$ -
	PG Guard	Pump/Grille Guard	39	\$ 626	18%	\$ -
	06200609	50" Blade Bar Kit (bar,knives,bolts,nuts)	75	\$ 1,088	18%	\$ -
	06200670	60" Blade Bar Kit (bar,knives,bolts,nuts)	85	\$ 1,187	18%	\$ -
	06744050	50" Rotary Disk Kit (knives,bolts,nuts,filter,grease) BRUSH	36	\$ 359	18%	\$ 302.58
	06744051	50" Rotary Disk Kit (knives,bolts,nuts,filter,grease) GRASS	39	\$ 374	18%	\$ -
	06744040	50/60" Rotary Blade Bar Kit (knives,bolts,nuts,filter,grease) BRUSH	36	\$ 318	18%	\$ -
	06744001	60" Rotary Disc Kit (knives,bolts,nuts,filter,grease) GRASS	39	\$ 246	18%	\$ -
	06744005	50" Flail Parts Kit (knives,bolts,nuts,filter,clevis,belts) LBG FLAIL	32	\$ 816	18%	\$ -
	06744043	50" Flail Parts Kit (knives,bolts,nuts,filter,clevis,belts) MBG FLAIL	58	\$ 1,875	18%	\$ -
	06744044	50" Flail Parts Kit (knives,bolts,nuts,filter,clevis,belts) HDB FLAIL	55	\$ 1,829	18%	\$ -
	06744006	63" Flail Parts Kit (knives,bolts,nuts,filter,clevis,belts) GRASS	44	\$ 585	18%	\$ -
	06744086	Mulcher Knife Kit (knives,bolts - set of 30)	30	\$ 878	18%	\$ -
		Backup Alarm		\$ 560	18%	\$ -
		Radio, AM/FM Stereo.		\$ 431	18%	\$ -
ADDITIONAL OPTIONS FROM PRICE LIST						
1		Light, Strobe		\$ 761	18%	\$ 624.02
1		Radio, AM/FM Stereo,		\$ 431	18%	\$ 353.42
12		Dealer PDI (prep,delivery,installation) Hourly Rate	Net Per Hour	\$ 210		\$ 2,520.00
						\$ -
						\$ -
						\$ -
Totals						\$ 163,244.10

TRACTOR INFORMATION REQUIRED:		Transmission	_____
Make/Model:	_____	Cab Type	_____
Tire size	_____	2WD or MFWD	_____
	Front		
	Rear		

All prices are FOB Destination.
Prices are subject to change without notice.

070821-TGR



Solicitation Number: RFP #070821

CONTRACT

This Contract is between Sourcewell, 202 12th Street Northeast, P.O. Box 219, Staples, MN 56479 (Sourcewell) and Tiger Corporation, 3301 N. Louise Ave., Sioux Falls, SD 57107 (Supplier).

Sourcewell is a State of Minnesota local government unit and service cooperative created under the laws of the State of Minnesota (Minnesota Statutes Section 123A.21) that offers cooperative procurement solutions to government entities. Participation is open to eligible federal, state/province, and municipal governmental entities, higher education, K-12 education, nonprofit, tribal government, and other public entities located in the United States and Canada. Sourcewell issued a public solicitation for Road Right-of-Way Maintenance Equipment from which Supplier was awarded a contract.

Supplier desires to contract with Sourcewell to provide equipment, products, or services to Sourcewell and the entities that access Sourcewell's cooperative purchasing contracts (Participating Entities).

1. TERM OF CONTRACT

- A. **EFFECTIVE DATE.** This Contract is effective upon the date of the final signature below.
- B. **EXPIRATION DATE AND EXTENSION.** This Contract expires August 9, 2025, unless it is cancelled sooner pursuant to Article 22. This Contract may be extended one additional year upon the request of Sourcewell and written agreement by Supplier.
- C. **SURVIVAL OF TERMS.** Notwithstanding any expiration or termination of this Contract, all payment obligations incurred prior to expiration or termination will survive, as will the following: Articles 11 through 14 survive the expiration or cancellation of this Contract. All rights will cease upon expiration or termination of this Contract.

2. EQUIPMENT, PRODUCTS, OR SERVICES

- A. **EQUIPMENT, PRODUCTS, OR SERVICES.** Supplier will provide the Equipment, Products, or Services as stated in its Proposal submitted under the Solicitation Number listed above.

070821-TGR

Supplier's Equipment, Products, or Services Proposal (Proposal) is attached and incorporated into this Contract.

All Equipment and Products provided under this Contract must be new and the current model. Supplier may offer close-out or refurbished Equipment or Products if they are clearly indicated in Supplier's product and pricing list. Unless agreed to by the Participating Entities in advance, Equipment or Products must be delivered as operational to the Participating Entity's site.

This Contract offers an indefinite quantity of sales, and while substantial volume is anticipated, sales and sales volume are not guaranteed.

B. **WARRANTY.** Supplier warrants that all Equipment, Products, and Services furnished are free from liens and encumbrances, and are free from defects in design, materials, and workmanship. In addition, Supplier warrants the Equipment, Products, and Services are suitable for and will perform in accordance with the ordinary use for which they are intended. Supplier's dealers and distributors must agree to assist the Participating Entity in reaching a resolution in any dispute over warranty terms with the manufacturer. Any manufacturer's warranty that extends beyond the expiration of the Supplier's warranty will be passed on to the Participating Entity.

C. **DEALERS, DISTRIBUTORS, AND/OR RESELLERS.** Upon Contract execution and throughout the Contract term, Supplier must provide to Sourcewell a current means to validate or authenticate Supplier's authorized dealers, distributors, or resellers relative to the Equipment, Products, and Services offered under this Contract, which will be incorporated into this Contract by reference. It is the Supplier's responsibility to ensure Sourcewell receives the most current information.

3. PRICING

All Equipment, Products, or Services under this Contract will be priced at or below the price stated in Supplier's Proposal.

When providing pricing quotes to Participating Entities, all pricing quoted must reflect a Participating Entity's total cost of acquisition. This means that the quoted cost is for delivered Equipment, Products, and Services that are operational for their intended purpose, and includes all costs to the Participating Entity's requested delivery location.

Regardless of the payment method chosen by the Participating Entity, the total cost associated with any purchase option of the Equipment, Products, or Services must always be disclosed in the pricing quote to the applicable Participating Entity at the time of purchase.

A. **SHIPPING AND SHIPPING COSTS.** All delivered Equipment and Products must be properly packaged. Damaged Equipment and Products may be rejected. If the damage is not readily apparent at the time of delivery, Supplier must permit the Equipment and Products to be

070821-TGR

returned within a reasonable time at no cost to Sourcewell or its Participating Entities. Participating Entities reserve the right to inspect the Equipment and Products at a reasonable time after delivery where circumstances or conditions prevent effective inspection of the Equipment and Products at the time of delivery. In the event of the delivery of nonconforming Equipment and Products, the Participating Entity will notify the Supplier as soon as possible and the Supplier will replace nonconforming Equipment and Products with conforming Equipment and Products that are acceptable to the Participating Entity.

Supplier must arrange for and pay for the return shipment on Equipment and Products that arrive in a defective or inoperable condition.

Sourcewell may declare the Supplier in breach of this Contract if the Supplier intentionally delivers substandard or inferior Equipment or Products.

B. SALES TAX. Each Participating Entity is responsible for supplying the Supplier with valid tax-exemption certification(s). When ordering, a Participating Entity must indicate if it is a tax-exempt entity.

C. HOT LIST PRICING. At any time during this Contract, Supplier may offer a specific selection of Equipment, Products, or Services at discounts greater than those listed in the Contract. When Supplier determines it will offer Hot List Pricing, it must be submitted electronically to Sourcewell in a line-item format. Equipment, Products, or Services may be added or removed from the Hot List at any time through a Sourcewell Price and Product Change Form as defined in Article 4 below.

Hot List program and pricing may also be used to discount and liquidate close-out and discontinued Equipment and Products as long as those close-out and discontinued items are clearly identified as such. Current ordering process and administrative fees apply. Hot List Pricing must be published and made available to all Participating Entities.

4. PRODUCT AND PRICING CHANGE REQUESTS

Supplier may request Equipment, Product, or Service changes, additions, or deletions at any time. All requests must be made in writing by submitting a signed Sourcewell Price and Product Change Request Form to the assigned Sourcewell Supplier Development Administrator. This approved form is available from the assigned Sourcewell Supplier Development Administrator. At a minimum, the request must:

- Identify the applicable Sourcewell contract number;
- Clearly specify the requested change;
- Provide sufficient detail to justify the requested change;

070821-TGR

- Individually list all Equipment, Products, or Services affected by the requested change, along with the requested change (e.g., addition, deletion, price change); and
- Include a complete restatement of pricing documentation in Microsoft Excel with the effective date of the modified pricing, or product addition or deletion. The new pricing restatement must include all Equipment, Products, and Services offered, even for those items where pricing remains unchanged.

A fully executed Sourcewell Price and Product Request Form will become an amendment to this Contract and will be incorporated by reference.

5. PARTICIPATION, CONTRACT ACCESS, AND PARTICIPATING ENTITY REQUIREMENTS

A. PARTICIPATION. Sourcewell's cooperative contracts are available and open to public and nonprofit entities across the United States and Canada; such as federal, state/province, municipal, K-12 and higher education, tribal government, and other public entities.

The benefits of this Contract should be available to all Participating Entities that can legally access the Equipment, Products, or Services under this Contract. A Participating Entity's authority to access this Contract is determined through its cooperative purchasing, interlocal, or joint powers laws. Any entity accessing benefits of this Contract will be considered a Service Member of Sourcewell during such time of access. Supplier understands that a Participating Entity's use of this Contract is at the Participating Entity's sole convenience and Participating Entities reserve the right to obtain like Equipment, Products, or Services from any other source.

Supplier is responsible for familiarizing its sales and service forces with Sourcewell contract use eligibility requirements and documentation and will encourage potential participating entities to join Sourcewell. Sourcewell reserves the right to add and remove Participating Entities to its roster during the term of this Contract.

B. PUBLIC FACILITIES. Supplier's employees may be required to perform work at government-owned facilities, including schools. Supplier's employees and agents must conduct themselves in a professional manner while on the premises, and in accordance with Participating Entity policies and procedures, and all applicable laws.

6. PARTICIPATING ENTITY USE AND PURCHASING

A. ORDERS AND PAYMENT. To access the contracted Equipment, Products, or Services under this Contract, a Participating Entity must clearly indicate to Supplier that it intends to access this Contract; however, order flow and procedure will be developed jointly between Sourcewell and Supplier. Typically, a Participating Entity will issue an order directly to Supplier or its authorized subsidiary, distributor, dealer, or reseller. If a Participating Entity issues a purchase order, it may use its own forms, but the purchase order should clearly note the applicable Sourcewell

070821-TGR

contract number. All Participating Entity orders under this Contract must be issued prior to expiration or cancellation of this Contract; however, Supplier performance, Participating Entity payment obligations, and any applicable warranty periods or other Supplier or Participating Entity obligations may extend beyond the term of this Contract.

Supplier's acceptable forms of payment are included in its attached Proposal. Participating Entities will be solely responsible for payment and Sourcewell will have no liability for any unpaid invoice of any Participating Entity.

B. ADDITIONAL TERMS AND CONDITIONS/PARTICIPATING ADDENDUM. Additional terms and conditions to a purchase order, or other required transaction documentation, may be negotiated between a Participating Entity and Supplier, such as job or industry-specific requirements, legal requirements (e.g., affirmative action or immigration status requirements), or specific local policy requirements. Some Participating Entities may require the use of a Participating Addendum; the terms of which will be negotiated directly between the Participating Entity and the Supplier. Any negotiated additional terms and conditions must never be less favorable to the Participating Entity than what is contained in this Contract.

C. SPECIALIZED SERVICE REQUIREMENTS. In the event that the Participating Entity requires service or specialized performance requirements not addressed in this Contract (such as e-commerce specifications, specialized delivery requirements, or other specifications and requirements), the Participating Entity and the Supplier may enter into a separate, standalone agreement, apart from this Contract. Sourcewell, including its agents and employees, will not be made a party to a claim for breach of such agreement.

D. TERMINATION OF ORDERS. Participating Entities may terminate an order, in whole or in part, immediately upon notice to Supplier in the event of any of the following events:

1. The Participating Entity fails to receive funding or appropriation from its governing body at levels sufficient to pay for the equipment, products, or services to be purchased; or
2. Federal, state, or provincial laws or regulations prohibit the purchase or change the Participating Entity's requirements.

E. GOVERNING LAW AND VENUE. The governing law and venue for any action related to a Participating Entity's order will be determined by the Participating Entity making the purchase.

7. CUSTOMER SERVICE

A. PRIMARY ACCOUNT REPRESENTATIVE. Supplier will assign an Account Representative to Sourcewell for this Contract and must provide prompt notice to Sourcewell if that person is changed. The Account Representative will be responsible for:

070821-TGR

- Maintenance and management of this Contract;
- Timely response to all Sourcewell and Participating Entity inquiries; and
- Business reviews to Sourcewell and Participating Entities, if applicable.

B. **BUSINESS REVIEWS.** Supplier must perform a minimum of one business review with Sourcewell per contract year. The business review will cover sales to Participating Entities, pricing and contract terms, administrative fees, sales data reports, supply issues, customer issues, and any other necessary information.

8. REPORT ON CONTRACT SALES ACTIVITY AND ADMINISTRATIVE FEE PAYMENT

A. **CONTRACT SALES ACTIVITY REPORT.** Each calendar quarter, Supplier must provide a contract sales activity report (Report) to the Sourcewell Supplier Development Administrator assigned to this Contract. Reports are due no later than 45 days after the end of each calendar quarter. A Report must be provided regardless of the number or amount of sales during that quarter (i.e., if there are no sales, Supplier must submit a report indicating no sales were made).

The Report must contain the following fields:

- Participating Entity Name (e.g., City of Staples Highway Department);
- Participating Entity Physical Street Address;
- Participating Entity City;
- Participating Entity State/Province;
- Participating Entity Zip/Postal Code;
- Participating Entity Contact Name;
- Participating Entity Contact Email Address;
- Participating Entity Contact Telephone Number;
- Sourcewell Assigned Entity/Participating Entity Number;
- Item Purchased Description;
- Item Purchased Price;
- Sourcewell Administrative Fee Applied; and
- Date Purchase was invoiced/sale was recognized as revenue by Supplier.

B. **ADMINISTRATIVE FEE.** In consideration for the support and services provided by Sourcewell, the Supplier will pay an administrative fee to Sourcewell on all Equipment, Products, and Services provided to Participating Entities. The Administrative Fee must be included in, and not added to, the pricing. Supplier may not charge Participating Entities more than the contracted price to offset the Administrative Fee.

The Supplier will submit payment to Sourcewell for the percentage of administrative fee stated in the Proposal multiplied by the total sales of all Equipment, Products, and Services purchased

070821-TGR

by Participating Entities under this Contract during each calendar quarter. Payments should note the Supplier's name and Sourcewell-assigned contract number in the memo; and must be mailed to the address above "Attn: Accounts Receivable" or remitted electronically to Sourcewell's banking institution per Sourcewell's Finance department instructions. Payments must be received no later than 45 calendar days after the end of each calendar quarter.

Supplier agrees to cooperate with Sourcewell in auditing transactions under this Contract to ensure that the administrative fee is paid on all items purchased under this Contract.

In the event the Supplier is delinquent in any undisputed administrative fees, Sourcewell reserves the right to cancel this Contract and reject any proposal submitted by the Supplier in any subsequent solicitation. In the event this Contract is cancelled by either party prior to the Contract's expiration date, the administrative fee payment will be due no more than 30 days from the cancellation date.

9. AUTHORIZED REPRESENTATIVE

Sourcewell's Authorized Representative is its Chief Procurement Officer.

Supplier's Authorized Representative is the person named in the Supplier's Proposal. If Supplier's Authorized Representative changes at any time during this Contract, Supplier must promptly notify Sourcewell in writing.

10. AUDIT, ASSIGNMENT, AMENDMENTS, WAIVER, AND CONTRACT COMPLETE

A. **AUDIT.** Pursuant to Minnesota Statutes Section 16C.05, subdivision 5, the books, records, documents, and accounting procedures and practices relevant to this Agreement are subject to examination by Sourcewell or the Minnesota State Auditor for a minimum of six years from the end of this Contract. This clause extends to Participating Entities as it relates to business conducted by that Participating Entity under this Contract.

B. **ASSIGNMENT.** Neither party may assign or otherwise transfer its rights or obligations under this Contract without the prior written consent of the other party and a fully executed assignment agreement. Such consent will not be unreasonably withheld. Any prohibited assignment will be invalid.

C. **AMENDMENTS.** Any amendment to this Contract must be in writing and will not be effective until it has been duly executed by the parties.

D. **WAIVER.** Failure by either party to take action or assert any right under this Contract will not be deemed a waiver of such right in the event of the continuation or repetition of the circumstances giving rise to such right. Any such waiver must be in writing and signed by the parties.

E. **CONTRACT COMPLETE.** This Contract represents the complete agreement between the parties. No other understanding regarding this Contract, whether written or oral, may be used to bind either party. For any conflict between the attached Proposal and the terms set out in Articles 1-22 of this Contract, the terms of Articles 1-22 will govern.

F. **RELATIONSHIP OF THE PARTIES.** The relationship of the parties is one of independent contractors, each free to exercise judgment and discretion with regard to the conduct of their respective businesses. This Contract does not create a partnership, joint venture, or any other relationship such as master-servant, or principal-agent.

11. INDEMNITY AND HOLD HARMLESS

Supplier must indemnify, defend, save, and hold Sourcewell and its Participating Entities, including their agents and employees, harmless from any claims or causes of action, including attorneys' fees incurred by Sourcewell or its Participating Entities, arising out of any act or omission in the performance of this Contract by the Supplier or its agents or employees; this indemnification includes injury or death to person(s) or property alleged to have been caused by some defect in the Equipment, Products, or Services under this Contract to the extent the Equipment, Product, or Service has been used according to its specifications. Sourcewell's responsibility will be governed by the State of Minnesota's Tort Liability Act (Minnesota Statutes Chapter 466) and other applicable law.

12. GOVERNMENT DATA PRACTICES

Supplier and Sourcewell must comply with the Minnesota Government Data Practices Act, Minnesota Statutes Chapter 13, as it applies to all data provided by or provided to Sourcewell under this Contract and as it applies to all data created, collected, received, stored, used, maintained, or disseminated by the Supplier under this Contract.

13. INTELLECTUAL PROPERTY, PUBLICITY, MARKETING, AND ENDORSEMENT

A. INTELLECTUAL PROPERTY

1. *Grant of License.* During the term of this Contract:
 - a. Sourcewell grants to Supplier a royalty-free, worldwide, non-exclusive right and license to use the trademark(s) provided to Supplier by Sourcewell in advertising and promotional materials for the purpose of marketing Sourcewell's relationship with Supplier.
 - b. Supplier grants to Sourcewell a royalty-free, worldwide, non-exclusive right and license to use Supplier's trademarks in advertising and promotional materials for the purpose of marketing Supplier's relationship with Sourcewell.
2. *Limited Right of Sublicense.* The right and license granted herein includes a limited right of each party to grant sublicenses to their respective subsidiaries, distributors, dealers,

resellers, marketing representatives, and agents (collectively "Permitted Sublicensees") in advertising and promotional materials for the purpose of marketing the Parties' relationship to Participating Entities. Any sublicense granted will be subject to the terms and conditions of this Article. Each party will be responsible for any breach of this Article by any of their respective sublicensees.

3. Use; Quality Control.

- a. Neither party may alter the other party's trademarks from the form provided and must comply with removal requests as to specific uses of its trademarks or logos.
- b. Each party agrees to use, and to cause its Permitted Sublicensees to use, the other party's trademarks only in good faith and in a dignified manner consistent with such party's use of the trademarks. Upon written notice to the breaching party, the breaching party has 30 days of the date of the written notice to cure the breach or the license will be terminated.

4. As applicable, Supplier agrees to indemnify and hold harmless Sourcewell and its Participating Entities against any and all suits, claims, judgments, and costs instituted or recovered against Sourcewell or Participating Entities by any person on account of the use of any Equipment or Products by Sourcewell or its Participating Entities supplied by Supplier in violation of applicable patent or copyright laws.

5. Termination. Upon the termination of this Contract for any reason, each party, including Permitted Sublicensees, will have 30 days to remove all Trademarks from signage, websites, and the like bearing the other party's name or logo (excepting Sourcewell's pre-printed catalog of suppliers which may be used until the next printing). Supplier must return all marketing and promotional materials, including signage, provided by Sourcewell, or dispose of it according to Sourcewell's written directions.

B. PUBLICITY. Any publicity regarding the subject matter of this Contract must not be released without prior written approval from the Authorized Representatives. Publicity includes notices, informational pamphlets, press releases, research, reports, signs, and similar public notices prepared by or for the Supplier individually or jointly with others, or any subcontractors, with respect to the program, publications, or services provided resulting from this Contract.

C. MARKETING. Any direct advertising, marketing, or offers with Participating Entities must be approved by Sourcewell. Send all approval requests to the Sourcewell Supplier Development Administrator assigned to this Contract.

D. ENDORSEMENT. The Supplier must not claim that Sourcewell endorses its Equipment, Products, or Services.

14. GOVERNING LAW, JURISDICTION, AND VENUE

The substantive and procedural laws of the State of Minnesota will govern this Contract. Venue for all legal proceedings arising out of this Contract, or its breach, must be in the appropriate state court in Todd County, Minnesota or federal court in Fergus Falls, Minnesota.

15. FORCE MAJEURE

Neither party to this Contract will be held responsible for delay or default caused by acts of God or other conditions that are beyond that party's reasonable control. A party defaulting under this provision must provide the other party prompt written notice of the default.

16. SEVERABILITY

If any provision of this Contract is found by a court of competent jurisdiction to be illegal, unenforceable, or void then both parties will be relieved from all obligations arising from that provision. If the remainder of this Contract is capable of being performed, it will not be affected by such determination or finding and must be fully performed.

17. PERFORMANCE, DEFAULT, AND REMEDIES

A. PERFORMANCE. During the term of this Contract, the parties will monitor performance and address unresolved contract issues as follows:

1. *Notification.* The parties must promptly notify each other of any known dispute and work in good faith to resolve such dispute within a reasonable period of time. If necessary, Sourcewell and the Supplier will jointly develop a short briefing document that describes the issue(s), relevant impact, and positions of both parties.
2. *Escalation.* If parties are unable to resolve the issue in a timely manner, as specified above, either Sourcewell or Supplier may escalate the resolution of the issue to a higher level of management. The Supplier will have 30 calendar days to cure an outstanding issue.
3. *Performance while Dispute is Pending.* Notwithstanding the existence of a dispute, the Supplier must continue without delay to carry out all of its responsibilities under the Contract that are not affected by the dispute. If the Supplier fails to continue without delay to perform its responsibilities under the Contract, in the accomplishment of all undisputed work, the Supplier will bear any additional costs incurred by Sourcewell and/or its Participating Entities as a result of such failure to proceed.

B. DEFAULT AND REMEDIES. Either of the following constitutes cause to declare this Contract, or any Participating Entity order under this Contract, in default:

1. Nonperformance of contractual requirements, or
2. A material breach of any term or condition of this Contract.

The party claiming default must provide written notice of the default, with 30 calendar days to cure the default. Time allowed for cure will not diminish or eliminate any liability for liquidated or other damages. If the default remains after the opportunity for cure, the non-defaulting party may:

- Exercise any remedy provided by law or equity, or
- Terminate the Contract or any portion thereof, including any orders issued against the Contract.

18. INSURANCE

A. REQUIREMENTS. At its own expense, Supplier must maintain insurance policy(ies) in effect at all times during the performance of this Contract with insurance company(ies) licensed or authorized to do business in the State of Minnesota having an "AM BEST" rating of A- or better, with coverage and limits of insurance not less than the following:

1. *Workers' Compensation and Employer's Liability.*

Workers' Compensation: As required by any applicable law or regulation.

Employer's Liability Insurance: must be provided in amounts not less than listed below:

Minimum limits:

\$500,000 each accident for bodily injury by accident

\$500,000 policy limit for bodily injury by disease

\$500,000 each employee for bodily injury by disease

2. *Commercial General Liability Insurance.* Supplier will maintain insurance covering its operations, with coverage on an occurrence basis, and must be subject to terms no less broad than the Insurance Services Office ("ISO") Commercial General Liability Form CG0001 (2001 or newer edition), or equivalent. At a minimum, coverage must include liability arising from premises, operations, bodily injury and property damage, independent contractors, products-completed operations including construction defect, contractual liability, blanket contractual liability, and personal injury and advertising injury. All required limits, terms and conditions of coverage must be maintained during the term of this Contract.

Minimum Limits:

\$1,000,000 each occurrence Bodily Injury and Property Damage

\$1,000,000 Personal and Advertising Injury

\$2,000,000 aggregate for Products-Completed operations

\$2,000,000 general aggregate

3. *Commercial Automobile Liability Insurance.* During the term of this Contract, Supplier will maintain insurance covering all owned, hired, and non-owned automobiles in limits of liability not less than indicated below. The coverage must be subject to terms

070821-TGR

no less broad than ISO Business Auto Coverage Form CA 0001 (2010 edition or newer), or equivalent.

Minimum Limits:

\$1,000,000 each accident, combined single limit

4. *Umbrella Insurance.* During the term of this Contract, Supplier will maintain umbrella coverage over Employer's Liability, Commercial General Liability, and Commercial Automobile.

Minimum Limits:

\$2,000,000

5. *Network Security and Privacy Liability Insurance.* During the term of this Contract, Supplier will maintain coverage for network security and privacy liability. The coverage may be endorsed on another form of liability coverage or written on a standalone policy. The insurance must cover claims which may arise from failure of Supplier's security resulting in, but not limited to, computer attacks, unauthorized access, disclosure of not public data – including but not limited to, confidential or private information, transmission of a computer virus, or denial of service.

Minimum limits:

\$2,000,000 per occurrence

\$2,000,000 annual aggregate

Failure of Supplier to maintain the required insurance will constitute a material breach entitling Sourcewell to immediately terminate this Contract for default.

B. **CERTIFICATES OF INSURANCE.** Prior to commencing under this Contract, Supplier must furnish to Sourcewell a certificate of insurance, as evidence of the insurance required under this Contract. Prior to expiration of the policy(ies), renewal certificates must be mailed to Sourcewell, 202 12th Street Northeast, P.O. Box 219, Staples, MN 56479 or sent to the Sourcewell Supplier Development Administrator assigned to this Contract. The certificates must be signed by a person authorized by the insurer(s) to bind coverage on their behalf.

Failure to request certificates of insurance by Sourcewell, or failure of Supplier to provide certificates of insurance, in no way limits or relieves Supplier of its duties and responsibilities in this Contract.

C. **ADDITIONAL INSURED ENDORSEMENT AND PRIMARY AND NON-CONTRIBUTORY INSURANCE CLAUSE.** Supplier agrees to list Sourcewell and its Participating Entities, including their officers, agents, and employees, as an additional insured under the Supplier's commercial general liability insurance policy with respect to liability arising out of activities, "operations," or "work" performed by or on behalf of Supplier, and products and completed operations of Supplier. The policy provision(s) or endorsement(s) must further provide that coverage is

070821-TGR

primary and not excess over or contributory with any other valid, applicable, and collectible insurance or self-insurance in force for the additional insureds.

D. **WAIVER OF SUBROGATION.** Supplier waives and must require (by endorsement or otherwise) all its insurers to waive subrogation rights against Sourcewell and other additional insureds for losses paid under the insurance policies required by this Contract or other insurance applicable to the Supplier or its subcontractors. The waiver must apply to all deductibles and/or self-insured retentions applicable to the required or any other insurance maintained by the Supplier or its subcontractors. Where permitted by law, Supplier must require similar written express waivers of subrogation and insurance clauses from each of its subcontractors.

E. **UMBRELLA/EXCESS LIABILITY/SELF-INSURED RETENTION.** The limits required by this Contract can be met by either providing a primary policy or in combination with umbrella/excess liability policy(ies), or self-insured retention.

19. COMPLIANCE

A. **LAWS AND REGULATIONS.** All Equipment, Products, or Services provided under this Contract must comply fully with applicable federal laws and regulations, and with the laws in the states and provinces in which the Equipment, Products, or Services are sold.

B. **LICENSES.** Supplier must maintain a valid and current status on all required federal, state/provincial, and local licenses, bonds, and permits required for the operation of the business that the Supplier conducts with Sourcewell and Participating Entities.

20. BANKRUPTCY, DEBARMENT, OR SUSPENSION CERTIFICATION

Supplier certifies and warrants that it is not in bankruptcy or that it has previously disclosed in writing certain information to Sourcewell related to bankruptcy actions. If at any time during this Contract Supplier declares bankruptcy, Supplier must immediately notify Sourcewell in writing.

Supplier certifies and warrants that neither it nor its principals are presently debarred, suspended, proposed for debarment, declared ineligible, or voluntarily excluded from programs operated by the State of Minnesota; the United States federal government or the Canadian government, as applicable; or any Participating Entity. Supplier certifies and warrants that neither it nor its principals have been convicted of a criminal offense related to the subject matter of this Contract. Supplier further warrants that it will provide immediate written notice to Sourcewell if this certification changes at any time.

21. PROVISIONS FOR NON-UNITED STATES FEDERAL ENTITY PROCUREMENTS UNDER UNITED STATES FEDERAL AWARDS OR OTHER AWARDS

Participating Entities that use United States federal grant or FEMA funds to purchase goods or services from this Contract may be subject to additional requirements including the procurement standards of the Uniform Administrative Requirements, Cost Principles and Audit Requirements for Federal Awards, 2 C.F.R. § 200. Participating Entities may have additional requirements based on specific funding source terms or conditions. Within this Article, all references to "federal" should be interpreted to mean the United States federal government. The following list only applies when a Participating Entity accesses Supplier's Equipment, Products, or Services with United States federal funds.

A. **EQUAL EMPLOYMENT OPPORTUNITY.** Except as otherwise provided under 41 C.F.R. § 60, all contracts that meet the definition of "federally assisted construction contract" in 41 C.F.R. § 60-1.3 must include the equal opportunity clause provided under 41 C.F.R. §60-1.4(b), in accordance with Executive Order 11246, "Equal Employment Opportunity" (30 FR 12319, 12935, 3 C.F.R. §, 1964-1965 Comp., p. 339), as amended by Executive Order 11375, "Amending Executive Order 11246 Relating to Equal Employment Opportunity," and implementing regulations at 41 C.F.R. § 60, "Office of Federal Contract Compliance Programs, Equal Employment Opportunity, Department of Labor." The equal opportunity clause is incorporated herein by reference.

B. **DAVIS-BACON ACT, AS AMENDED (40 U.S.C. § 3141-3148).** When required by federal program legislation, all prime construction contracts in excess of \$2,000 awarded by non-federal entities must include a provision for compliance with the Davis-Bacon Act (40 U.S.C. § 3141-3144, and 3146-3148) as supplemented by Department of Labor regulations (29 C.F.R. § 5, "Labor Standards Provisions Applicable to Contracts Covering Federally Financed and Assisted Construction"). In accordance with the statute, contractors must be required to pay wages to laborers and mechanics at a rate not less than the prevailing wages specified in a wage determination made by the Secretary of Labor. In addition, contractors must be required to pay wages not less than once a week. The non-federal entity must place a copy of the current prevailing wage determination issued by the Department of Labor in each solicitation. The decision to award a contract or subcontract must be conditioned upon the acceptance of the wage determination. The non-federal entity must report all suspected or reported violations to the federal awarding agency. The contracts must also include a provision for compliance with the Copeland "Anti-Kickback" Act (40 U.S.C. § 3145), as supplemented by Department of Labor regulations (29 C.F.R. § 3, "Contractors and Subcontractors on Public Building or Public Work Financed in Whole or in Part by Loans or Grants from the United States"). The Act provides that each contractor or subrecipient must be prohibited from inducing, by any means, any person employed in the construction, completion, or repair of public work, to give up any part of the compensation to which he or she is otherwise entitled. The non-federal entity must report all suspected or reported violations to the federal awarding agency. Supplier must be in compliance with all applicable Davis-Bacon Act provisions.

070821-TGR

C. CONTRACT WORK HOURS AND SAFETY STANDARDS ACT (40 U.S.C. § 3701-3708). Where applicable, all contracts awarded by the non-federal entity in excess of \$100,000 that involve the employment of mechanics or laborers must include a provision for compliance with 40 U.S.C. §§ 3702 and 3704, as supplemented by Department of Labor regulations (29 C.F.R. § 5). Under 40 U.S.C. § 3702 of the Act, each contractor must be required to compute the wages of every mechanic and laborer on the basis of a standard work week of 40 hours. Work in excess of the standard work week is permissible provided that the worker is compensated at a rate of not less than one and a half times the basic rate of pay for all hours worked in excess of 40 hours in the work week. The requirements of 40 U.S.C. § 3704 are applicable to construction work and provide that no laborer or mechanic must be required to work in surroundings or under working conditions which are unsanitary, hazardous or dangerous. These requirements do not apply to the purchases of supplies or materials or articles ordinarily available on the open market, or contracts for transportation or transmission of intelligence. This provision is hereby incorporated by reference into this Contract. Supplier certifies that during the term of an award for all contracts by Sourcewell resulting from this procurement process, Supplier must comply with applicable requirements as referenced above.

D. RIGHTS TO INVENTIONS MADE UNDER A CONTRACT OR AGREEMENT. If the federal award meets the definition of "funding agreement" under 37 C.F.R. § 401.2(a) and the recipient or subrecipient wishes to enter into a contract with a small business firm or nonprofit organization regarding the substitution of parties, assignment or performance of experimental, developmental, or research work under that "funding agreement," the recipient or subrecipient must comply with the requirements of 37 C.F.R. § 401, "Rights to Inventions Made by Nonprofit Organizations and Small Business Firms Under Government Grants, Contracts and Cooperative Agreements," and any implementing regulations issued by the awarding agency. Supplier certifies that during the term of an award for all contracts by Sourcewell resulting from this procurement process, Supplier must comply with applicable requirements as referenced above.

E. CLEAN AIR ACT (42 U.S.C. § 7401-7671Q.) AND THE FEDERAL WATER POLLUTION CONTROL ACT (33 U.S.C. § 1251-1387). Contracts and subgrants of amounts in excess of \$150,000 require the non-federal award to agree to comply with all applicable standards, orders or regulations issued pursuant to the Clean Air Act (42 U.S.C. § 7401- 7671q) and the Federal Water Pollution Control Act as amended (33 U.S.C. § 1251- 1387). Violations must be reported to the Federal awarding agency and the Regional Office of the Environmental Protection Agency (EPA). Supplier certifies that during the term of this Contract will comply with applicable requirements as referenced above.

F. DEBARMENT AND SUSPENSION (EXECUTIVE ORDERS 12549 AND 12689). A contract award (see 2 C.F.R. § 180.220) must not be made to parties listed on the government wide exclusions in the System for Award Management (SAM), in accordance with the OMB guidelines at 2 C.F.R. §180 that implement Executive Orders 12549 (3 C.F.R. § 1986 Comp., p. 189) and 12689 (3 C.F.R. § 1989 Comp., p. 235), "Debarment and Suspension." SAM Exclusions contains the names

of parties debarred, suspended, or otherwise excluded by agencies, as well as parties declared ineligible under statutory or regulatory authority other than Executive Order 12549. Supplier certifies that neither it nor its principals are presently debarred, suspended, proposed for debarment, declared ineligible, or voluntarily excluded from participation by any federal department or agency.

G. BYRD ANTI-LOBBYING AMENDMENT, AS AMENDED (31 U.S.C. § 1352). Suppliers must file any required certifications. Suppliers must not have used federal appropriated funds to pay any person or organization for influencing or attempting to influence an officer or employee of any agency, a member of Congress, officer or employee of Congress, or an employee of a member of Congress in connection with obtaining any federal contract, grant, or any other award covered by 31 U.S.C. § 1352. Suppliers must disclose any lobbying with non-federal funds that takes place in connection with obtaining any federal award. Such disclosures are forwarded from tier to tier up to the non-federal award. Suppliers must file all certifications and disclosures required by, and otherwise comply with, the Byrd Anti-Lobbying Amendment (31 U.S.C. § 1352).

H. RECORD RETENTION REQUIREMENTS. To the extent applicable, Supplier must comply with the record retention requirements detailed in 2 C.F.R. § 200.333. The Supplier further certifies that it will retain all records as required by 2 C.F.R. § 200.333 for a period of 3 years after grantees or subgrantees submit final expenditure reports or quarterly or annual financial reports, as applicable, and all other pending matters are closed.

I. ENERGY POLICY AND CONSERVATION ACT COMPLIANCE. To the extent applicable, Supplier must comply with the mandatory standards and policies relating to energy efficiency which are contained in the state energy conservation plan issued in compliance with the Energy Policy and Conservation Act.

J. BUY AMERICAN PROVISIONS COMPLIANCE. To the extent applicable, Supplier must comply with all applicable provisions of the Buy American Act. Purchases made in accordance with the Buy American Act must follow the applicable procurement rules calling for free and open competition.

K. ACCESS TO RECORDS (2 C.F.R. § 200.336). Supplier agrees that duly authorized representatives of a federal agency must have access to any books, documents, papers and records of Supplier that are directly pertinent to Supplier's discharge of its obligations under this Contract for the purpose of making audits, examinations, excerpts, and transcriptions. The right also includes timely and reasonable access to Supplier's personnel for the purpose of interview and discussion relating to such documents.

L. PROCUREMENT OF RECOVERED MATERIALS (2 C.F.R. § 200.322). A non-federal entity that is a state agency or agency of a political subdivision of a state and its contractors must comply with Section 6002 of the Solid Waste Disposal Act, as amended by the Resource Conservation

070821-TGR

and Recovery Act. The requirements of Section 6002 include procuring only items designated in guidelines of the Environmental Protection Agency (EPA) at 40 C.F.R. § 247 that contain the highest percentage of recovered materials practicable, consistent with maintaining a satisfactory level of competition, where the purchase price of the item exceeds \$10,000 or the value of the quantity acquired during the preceding fiscal year exceeded \$10,000; procuring solid waste management services in a manner that maximizes energy and resource recovery; and establishing an affirmative procurement program for procurement of recovered materials identified in the EPA guidelines.

M. FEDERAL SEAL(S), LOGOS, AND FLAGS. The Supplier not use the seal(s), logos, crests, or reproductions of flags or likenesses of Federal agency officials without specific pre-approval.

N. NO OBLIGATION BY FEDERAL GOVERNMENT. The U.S. federal government is not a party to this Contract or any purchase by an Participating Entity and is not subject to any obligations or liabilities to the Participating Entity, Supplier, or any other party pertaining to any matter resulting from the Contract or any purchase by an authorized user.

O. PROGRAM FRAUD AND FALSE OR FRAUDULENT STATEMENTS OR RELATED ACTS. The Contractor acknowledges that 31 U.S.C. 38 (Administrative Remedies for False Claims and Statements) applies to the Supplier's actions pertaining to this Contract or any purchase by a Participating Entity.

P. FEDERAL DEBT. The Supplier certifies that it is non-delinquent in its repayment of any federal debt. Examples of relevant debt include delinquent payroll and other taxes, audit disallowance, and benefit overpayments.

Q. CONFLICTS OF INTEREST. The Supplier must notify the U.S. Office of General Services, Sourcewell, and Participating Entity as soon as possible if this Contract or any aspect related to the anticipated work under this Contract raises an actual or potential conflict of interest (as described in 2 C.F.R. Part 200). The Supplier must explain the actual or potential conflict in writing in sufficient detail so that the U.S. Office of General Services, Sourcewell, and Participating Entity are able to assess the actual or potential conflict; and provide any additional information as necessary or requested.

R. U.S. EXECUTIVE ORDER 13224. The Supplier, and its subcontractors, must comply with U.S. Executive Order 13224 and U.S. Laws that prohibit transactions with and provision of resources and support to individuals and organizations associated with terrorism.

S. PROHIBITION ON CERTAIN TELECOMMUNICATIONS AND VIDEO SURVEILLANCE SERVICES OR EQUIPMENT. To the extent applicable, Supplier certifies that during the term of this Contract it will comply with applicable requirements of 2 C.F.R. § 200.216.

T. DOMESTIC PREFERENCES FOR PROCUREMENTS. To the extent applicable, Supplier certifies that during the term of this Contract will comply with applicable requirements of 2 C.F.R. § 200.322.

DocuSign Envelope ID: 84D53BCE-B0C8-4958-99A8-7B4B5EEEE084

070821-TGR

22. CANCELLATION

Sourcewell or Supplier may cancel this Contract at any time, with or without cause, upon 60 days' written notice to the other party. However, Sourcewell may cancel this Contract immediately upon discovery of a material defect in any certification made in Supplier's Proposal. Cancellation of this Contract does not relieve either party of financial, product, or service obligations incurred or accrued prior to cancellation.

Sourcewell

Tiger Corporation

DocuSigned by:
Jeremy Schwartz
By: C0FD2A139D06489...
Jeremy Schwartz
Title: Chief Procurement Officer
Date: 8/6/2021 | 7:33 AM CDT

DocuSigned by:
Shawn Cleary
By: E514F861F53F4DF...
Shawn Cleary
Title: President
Date: 8/5/2021 | 11:53 AM CDT

Approved:

DocuSigned by:
Chad Coauette
By: 7E42B87817A84CC...
Chad Coauette
Title: Executive Director/CEO
Date: 8/6/2021 | 7:37 AM CDT

DocuSign Envelope ID: 84D53BCE-B0C8-4958-99A8-7B4B5EEEE084

RFP 070821 - Road Right-of-Way Maintenance Equipment

Vendor Details

Company Name: Tiger Corporation
Address: 3301 North Louise Ave
SIOUX FALLS, South Dakota 57107
Contact: Dave Burkhart
Email: dburkhart@tigermowers.com
Phone: 605-261-8133
Fax: 605-261-8133
HST#: 88-0329653

Submission Details

Created On: Tuesday May 18, 2021 09:56:30
Submitted On: Friday July 02, 2021 12:33:20
Submitted By: Dave Burkhart
Email: dburkhart@tigermowers.com
Transaction #: e89231b6-b4b1-41f5-a03b-596eab16c601
Submitter's IP Address: 96.2.247.178

DocuSign Envelope ID: 84D53BCE-B0C8-4958-99A8-7B4B5EEEE084

Specifications

Table 1: Proposer Identity & Authorized Representatives

General Instructions (applies to all Tables) Sourcwell prefers a brief but thorough response to each question. Do not merely attach additional documents to your response without also providing a substantive response. Do not leave answers blank; respond "N/A" if the question does not apply to you (preferably with an explanation).

Line Item	Question	Response *
1	Proposer Legal Name (one legal entity only):	Tiger Corporation
2	Identify all subsidiary entities of the Proposer whose equipment, products, or services are included in the Proposal.	Tiger Corporation
3	Identify all applicable assumed names or DBA names of the Proposer or Proposer's subsidiaries in Line 1 or Line 2 above.	Tiger Corporation
4	Proposer Physical Address:	3301 N.Louise Ave. Sioux Falls, SD 57107
5	Proposer website address (or addresses):	www.tigemowers.com
6	Proposer's Authorized Representative (name, title, address, email address & phone) (The representative must have authority to sign the "Proposer's Assurance of Compliance" on behalf of the Proposer and, in the event of award, will be expected to execute the resulting contract):	Shawn Cleary, President of Tiger Corporation, 3301 N. Louise Ave Sioux Falls, SD 57107, scleary@tigemowers.com, 605-731-0404
7	Proposer's primary contact for this proposal (name, title, address, email address & phone):	Dave Burkhart, Marketing Coordinator, 3301 N. Louise Ave. Sioux Falls, SD 57107, dburkhart@tigemowers.com, 605-373-0447
8	Proposer's other contacts for this proposal, if any (name, title, address, email address & phone):	John Peters, National Sales Manager, 3301 N. Louise Ave. Sioux Falls, SD 57107, jpeters@tigemowers.com, 605-373-0439

Table 2: Company Information and Financial Strength

Line Item	Question	Response *
9	Provide a brief history of your company, including your company's core values, business philosophy, and industry longevity related to the requested equipment, products or services.	<p>Tiger Corporation was founded in 1968 with a simple idea, engineer and manufacture the best industrial strength road side mowers and roadway attachments for tractors and trucks. We have developed a complete line of high-quality mowing equipment. Tiger has an extensive Authorized Dealer network with 260 locations, trained to sell and support, our products in the North American market. Tiger is a proud member of, and a wholly-owned subsidiary of Alamo Group Inc. Founded in 1969, Alamo Group Inc. (NYSE: ALG) is a leader in the design, manufacture, distribution, and service of high-quality equipment for governmental, agricultural, and contractor/custom mowing markets. Alamo Group products include truck and tractor mounted mowing and other vegetation maintenance equipment, street sweepers, snow removal equipment, excavators, vacuum trucks, other industrial equipment, agricultural implements, and related after-market parts and services. Alamo Group's corporate headquarters is located in Seguin, Texas. Our 33 Alamo Group member companies are located throughout Australia, Europe, North America, and South America. The Company operates two separate business divisions, namely, the Industrial Division and the Agricultural Division.</p> <p>Tiger's Core Values:</p> <ol style="list-style-type: none"> 1. Teamwork- Creating great working relationships and innovative customer solutions for a productive work environment through respect, appreciation, and open communication. 2. Quality Products - We are committed to the highest standards of excellence in all phases of our business by using the best quality materials, demonstrating professionalism, providing the best service, and focusing on safety for our employees, dealers, and customers. 3. Positive Relationships - Maintain open and active relationships with our customers to provide the best service while always seeking to establish new relationships to grow our network and increase sales. <p>Tiger's business philosophy and Vision - To be the leader in the industrial mowing market. To provide innovative solutions, with high quality, user-friendly equipment, to solve the challenges of right of way/roadside mowing. Tiger's goal is to exceed our customers' expectations leveraging our extensive North American dealer network, by providing the best parts and service available today.</p>

Bid Number: RFP 070821

Vendor Name: Tiger Corporation

DocuSign Envelope ID: 84D53BCE-B0C8-4958-99A8-7B4B5EEEE084

10	What are your company's expectations in the event of an award?	In the last 4 years of being on the Sourcwell contract, 25% of Tigers' total sales have been generated from the Sourcwell contract. We are excited about having this contract as a key resource to leverage the growth of the Tiger brand and increase sales in North America, and bring the best value to Sourcwell members. Our team at Tiger Corporation looks forward to the continued benefits of using the Sourcwell contract. Many of our customers have stated that using the Sourcwell contract has streamlined their procurement process and has ensured that their governmental entity will receive a quality product for a competitive price. The Sales team at Tiger believes we will continue to grow our sales exponentially by continuing to leverage the Sourcwell contract. We believe the Sourcwell name is synonymous with strength and quality suppliers and provides customers with a contract that is easy to use. We look forward to continued growth if we are chosen to continue on this contract for another 4 years.
11	Demonstrate your financial strength and stability with meaningful data. This could include such items as financial statements, SEC filings, credit and bond ratings, letters of credit, and detailed reference letters. Upload supporting documents (as applicable) in the document upload section of your response.	Tiger Corporation is a wholly owned subsidiary of Alamo Group Inc., and does not publish individual company financial records. Attached in the Financial Strength and Stability Documents section are the following reports: 2020 Alamo Group Annual Report and 2021, 1st Quarter Financial Report. Also included are the Dunn & Bradstreet report, and credit references for Tiger Corporation.
12	What is your US market share for the solutions that you are proposing?	Tiger and its Authorized Dealer network, commands a 30% market share in the markets we participate in. Unfortunately, AEM does not track market share for industrial mowing equipment. Based on our 53 years of proven performance in the right of way roadside mowing market and the extrapolation of known sales we have on record within our CRM and in our business system, we believe our market share is as accurate as can be determined.
13	What is your Canadian market share for the solutions that you are proposing?	Our estimated market share in Canada is 7%. We are not satisfied with our current level of sales and we believe there is significant opportunity in the prairie provinces of Alberta, Saskatchewan, and Manitoba. We recently added a new dealer in Ontario and they are growing our sales significantly in Ontario and Quebec. Here at Tiger, we see nothing but opportunity and growth in Canada. We look forward to partnering with Sourcwell and Rural Municipalities of Alberta to continue to grow our sales. Due to Covid-19 travel restrictions between the United States and Canada, we were not able to continue our travels and prospecting for new/additional dealers in Canada in 2020. As soon as travel restrictions are lifted, we plan to continue our focused efforts in growing our dealer network in Canada.
14	Has your business ever petitioned for bankruptcy protection? If so, explain in detail.	Tiger Corporation has never been the subject of any bankruptcy action. There will not be any risk of bankruptcy in the foreseeable future with the financial strength of Alamo Group (corporate). As an Alamo Group company, we have sufficient resources to support our capital investments at our factory or financial operational needs as a company.
15	How is your organization best described: is it a manufacturer, a distributor/dealer/reseller, or a service provider? Answer whichever question (either a) or b) just below) best applies to your organization. a) If your company is best described as a distributor/dealer/reseller (or similar entity), provide your written authorization to act as a distributor/dealer/reseller for the manufacturer of the products proposed in this RFP. If applicable, is your dealer network independent or company owned? b) If your company is best described as a manufacturer or service provider, describe your relationship with your sales and service force and with your dealer network in delivering the products and services proposed in this RFP. Are these individuals your employees, or the employees of a third party?	Tiger is a manufacturing company that maintains a field sales staff that supports over 57 dealer organizations with 260 locations that cover the US and Canadian market areas. Tiger authorized dealers are the key, and responsible for selling directly to City, County, State, and Federal government agencies and servicing products from these local dealership locations. Tiger's has a total of 14 employees that are directly involved in the day to day activities of selling and supporting our products and provide support to our dealer channel. Tiger's authorized dealers are also agricultural, municipal, and construction equipment dealers, with brick and mortar locations throughout North America. Our dealers offer world-class solutions to governmental customers, agricultural producers, and the contractor segment of the market. Our diverse dealer network is a strength of Tiger Corporation as it helps us gain additional brand awareness in three distinct markets (Municipal, Agricultural, and Construction customers).
16	If applicable, provide a detailed explanation outlining the licenses and certifications that are both required to be held, and actually held, by your organization (including third parties and subcontractors that you use) in pursuit of the business contemplated by this RFP.	Tiger Corporation manufactures all of its products to adhere to all specifications of the SAE, ASAE, and ANSI Standards of Industrial Mowing Equipment. These standards assure the customer and the public that Tiger equipment provides the highest degree of safety and durability. The testing is third-party tested to industry standards. One of our team members in our Engineering Department is a Registered Engineer (PE) that plays an integral part in our product development process. This individual has been with our company for over 25 years. In addition, we have 4 other team members in our engineering department that are continually working on value-added solutions to bring to the market and to enhance our current product line of right-of-way mowing equipment.
17	Provide all "Suspension or Debarment" information that has applied to your organization during the past ten years.	None to report. Not Applicable.

DocuSign Envelope ID: 84D53BCE-B0C8-4958-99A8-7B4B5EEEE084

Table 3: Industry Recognition & Marketplace Success

Line Item	Question	Response *
18	Describe any relevant industry awards or recognition that your company has received in the past five years	Alamo Group Companies were recognized as one of the top 100 ethical companies by Forbes in 2014, proving to our customers that they are working with a company that will treat them fairly and honestly. Tiger has received many safety awards, including the 2019 Safety Excellence Award for Zero Injuries by Alamo Group Corporate Safety team, and was also awarded the South Dakota Governors' Workplace safety award for 2015, 2016, 2017, 2018, 2019, and 2020.
19	What percentage of your sales are to the governmental sector in the past three years	An average of 90% of Tiger sales are to Governmental entities.
20	What percentage of your sales are to the education sector in the past three years	Since our products are mainly industrial mowing equipment approximately 5% annually of our sales are to educational entities and school districts.
21	List any state, provincial, or cooperative purchasing contracts that you hold. What is the annual sales volume for each of these contracts over the past three years?	Alabama State Contract = \$1,301,493 Arizona=\$312,792 Iowa State Contract = \$90,030 Kentucky State Contract = \$2,045,184 Minnesota State Contract = \$199,875 Oklahoma State Contract = \$57,490 Ohio State Contract= \$1,585,125 Pennsylvania State Contract = \$5,668,895 TX Buy Board = \$5,009,967 Washington (State) = \$1,591,458
22	List any GSA contracts or Standing Offers and Supply Arrangements (SOSA) that you hold. What is the annual sales volume for each of these contracts over the past three years?	Tiger does not hold a GSA contract, although our business partner EKA and associates offers Tiger products on their GSA contract. Sales volume for three years to EKA have been \$ 1,097,926.

Table 4: References/Testimonials

Line Item 23. Supply reference information from three customers who are eligible to be Sourcwell participating entities.

Entity Name *	Contact Name *	Phone Number *
Milwaukee County, Wisconsin	John Blonien Fleet Director	(414) 257-6575
Henry Miller Reclamation District (California)	Adam Coronado District Superintendent	209-587-1198
City of Spartanburg, SC	Johnny Ravan Roads & Bridges Manager	864-415-6846

Table 5: Top Five Government or Education Customers

Line Item 24. Provide a list of your top five government, education, or non-profit customers (entity name is optional), including entity type, the state or province the entity is located in, scope of the project(s), size of transaction(s), and dollar volumes from the past three years.

Entity Name	Entity Type *	State / Province *	Scope of Work *	Size of Transactions *	Dollar Volume Past Three Years *
State of West Virginia- Middletown Tractor	Government	West Virginia - WV	Tractor and Boom mower turnkey units with Rotary cutter heads, mulcher heads.	42 Units total in 2020	1.4 Million
State of Kentucky	Government	Kentucky - KY	Boom mowers with Rotary and Flail cutter heads, side Rotary mowers, side Flail mowers. Rear Flail mowers and Pull behind rotary mowers.	28 orders total in 2020	\$1.9 Million
PAMAC	Government	Pennsylvania - PA	Boom mowers with Rotary and Flail cutter heads, side Rotary mowers, side Flail mowers. Rear Flail mowers and Pull behind rotary mowers. Wildkat boom mowers, ditchers and mulching heads.	27 orders total in 2020	\$1.85 Million
Texas Buy Board	Government	Texas - TX	Boom mowers with Rotary and Flail cutter heads, side Rotary mowers, side Flail mowers. Rear Flail mowers and Pull behind rotary mowers. Wildkat boom mowers, ditchers and mulching heads.	37 orders total in 2020	\$1.7 Million
Ohio DOT	Government	Ohio - OH	Tractor and mower turnkey units with rotary and flail cutter heads. Ditchers.	22 orders total in 2020	\$1.6 Million

DocuSign Envelope ID: 84D53BCE-B0C8-4958-99A8-7B4B5EEEE084

Table 6: Ability to Sell and Deliver Service

Describe your company's capability to meet the needs of Sourcewell participating entities across the US and Canada, as applicable. Your response should address in detail at least the following areas: locations of your network of sales and service providers, the number of workers (full-time equivalents) involved in each sector, whether these workers are your direct employees (or employees of a third party), and any overlap between the sales and service functions.

Line Item	Question	Response *
25	Sales force.	Tiger's sales force consists of 5 Tiger Territory Sales Managers, 1 National Sales Manager, 1 sales support person, 2 service support people, 1 parts support person, 1 order fulfillment support person and 260 dealer locations to sell and support our products in North America.
26	Dealer network or other distribution methods.	Tiger has 57 Authorized Dealer organizations, which have 260 locations for the United States and Canada. Tiger Authorized Dealers call on and work with the vegetation management needs of the city, county, and state governmental entities in their assigned areas. Tiger Dealers have dedicated Governmental Specialists (salespeople), that spend 100% of their time on sales, product and customer support, and marketing of our products. Tiger employees have attended several H2O vendor programs in the last few years and have grown in knowledge from networking with other Sourcewell vendors and from the help of our Sourcewell representative.
27	Service force.	Tiger utilizes a factory-trained service force with our 57 Tiger Authorized Dealers, at their 260 locations. Tiger also has 2 factory product support people supporting our dealers. During the week, we have staff available for product support questions from 7:00 AM to 5:00 PM. If required, we dispatch a mobile technician to travel to our authorized dealers and customers in the field in the support of product concerns or technical issues, if they arise. Our factory technicians have over 100 years of combined experience. Tiger Authorized Dealers have factory trained technicians available on demand for our customers.
28	Describe in detail the process and procedure of your customer service program, if applicable. Include your response-time capabilities and commitments, as well as any incentives that help your providers meet your stated service goals or promises.	Tiger has a dedicated customer service team of 5 people to provide an instant or a same-day response to any customer need. We provide service access by phone, email, facetime, our website, and our dedicated Tiger service center website. Our computer software system logs each call so the customers' issue is documented and can be reviewed by another team member at any time. Customers generally initiate service requirements with our Tiger Authorized Dealers, however, our Customer Service Team will answer any customer-generated call. We also leverage our website www.tigerowers.com , which allows customers to download various parts and service manuals.
29	Describe your ability and willingness to provide your products and services to Sourcewell participating entities in the United States.	Tiger was awarded a Sourcewell contract 4 years ago and has a proven track record of taking care of the customer from the first phone call to several years after the sale. Tiger understands the responsibility we have every day in representing the Sourcewell name and we take it seriously. We pride ourselves on customer service and treating the customer like we would like to be treated. In this manner, the customer will want to come back for future purchases because they have received a positive ownership experience with our products.
30	Describe your ability and willingness to provide your products and services to Sourcewell participating entities in Canada.	Tiger is eager to use the Sourcewell contract in the Canadian provinces. We have found that the challenges in vegetation management in Canada are very similar to the challenges in the United States. Tiger has the vast product offering and dealer outlets needed to address the Canadian market.
31	Identify any geographic areas of the United States or Canada that you will NOT be fully serving through the proposed contract.	We are dedicated to supporting all the geographic areas of the United States and Canada. Tiger is proud of our strong dealer network along with the 260 locations in North America to support our customers' needs.
32	Identify any Sourcewell participating entity sectors (i.e., government, education, not-for-profit) that you will NOT be fully serving through the proposed contract. Explain in detail. For example, does your company have only a regional presence, or do other cooperative purchasing contracts limit your ability to promote another contract?	Tiger is committed to service all members that are eligible to purchase from the Sourcewell contract. Tiger's extensive North American dealer network enables us to make this commitment.
33	Define any specific contract requirements or restrictions that would apply to our participating entities in Hawaii and Alaska and in US Territories.	Tiger has authorized dealers in both Hawaii and Alaska to administer the Sourcewell contract. Tiger reserves the right to sell directly to any US Territory. A modest freight adjustment will be made to cover ocean freight.

DocuSign Envelope ID: 84D53BCE-B0C8-4956-99A8-7B4B5EEEE084

Table 7: Marketing Plan

Line Item	Question	Response *
34	Describe your marketing strategy for promoting this contract opportunity. Upload representative samples of your marketing materials (if applicable) in the document upload section of your response.	Since being awarded this contract in 2017, Tiger Corporation has enthusiastically promoted the Sourcewell contract. We have used the Sourcewell logo on many of our printed literature pieces, along with ads in several county and municipal advertising pieces. Tiger consistently uses Sourcewell in our Constant Contact emails sent out to over 4000 customers and dealer locations. Upon contract award, Tiger's marketing department will again promote the Sourcewell contact name in all our social media platforms, Constant Contact (email advertising campaign), along with another media blitz on Facebook and LinkedIn. Tiger attends local, regional, and national trade shows to continue to grow Sourcewell contract purchasing, and we proudly display the Sourcewell flags at our booth while attending these shows. Tiger currently has the Sourcewell logo posted on our website at the top of our awarded contract page, so new and existing customers have quick access to the website. We will continue to promote the Sourcewell name because of the high brand recognition along with 25% of Tiger's total sales in the past four years have come from this fantastic contract. Tiger Corporation has seen the value in the Sourcewell contract and will continue to reach out to all our customers to promote Sourcewell. Copy of Tiger Boom Mower Literature with Sourcewell Logo, copy of Awarded Contracts page on Tiger website, and copy of Constant Contact piece using Sourcewell have been uploaded to "Marketing" documents area.
35	Describe your use of technology and digital data (e.g., social media, metadata usage) to enhance marketing effectiveness.	Tiger has continually promoted Sourcewell on our website along with many print materials and social media websites to show the ease of purchasing Tiger products using the Sourcewell contract. We have designed Sourcewell specific quote sheets to make ordering easy and fast for the customer. Tiger utilizes Salesforce.com for customer database information and uses Constant Contact, Facebook, and LinkedIn, for Tiger's digital marketing. Bi-weekly email blasts are sent to the customer base to allow Tiger and Sourcewell to stay "top of mind" for our customers. Tiger strives to use Facebook on product deliveries, customer training events and promotes the Sourcewell name when possible.
36	In your view, what is Sourcewell's role in promoting contracts arising out of this RFP? How will you integrate a Sourcewell-awarded contract into your sales process?	Sourcewell has offered Tiger many resources and support in our current contract, which we have utilized to promote cooperative buying. Sourcewell's brand recognition has added great value to Tiger and increased the recognition of our brand name in North America. Our sales team utilizes the Sourcewell name and reputation it carries, in print ads, social media, and the many trade shows we attend. Tiger Corporation will continue to use our sales team and dealer network to provide top-of-the-line products, leveraging Sourcewell as the most cost effective way to purchase Tiger products. The Tiger Sales and Marketing Team will continue to design new marketing materials promoting Sourcewell and introduce the Sourcewell contract at every opportunity.
37	Are your products or services available through an e-procurement ordering process? If so, describe your e-procurement system and how governmental and educational customers have used it.	Currently, e-procurement is not available on Tiger products. Tiger believes our product line requires hands-on personal service for the sale of products at the customer level. With the wide variety of right-of-way mowing equipment and infinite problems with vegetation management we feel we cannot provide the best customer service with e-procurement at this time. Tiger's products are procured through our Tiger Authorized Dealer network. Tiger works directly with our authorized dealers and customers to give the best customer service to provide the solution to the customer's most difficult problems and exceed the customer's expectations.

DocuSign Envelope ID: 84D53BCE-B0C8-4958-99A8-7B4B5EEEE084

Table 8: Value-Added Attributes

Line Item	Question	Response *
38	Describe any product, equipment, maintenance, or operator training programs that you offer to Sourcwell participating entities. Include details, such as whether training is standard or optional, who provides training, and any costs that apply.	Every Tiger customer is trained on the operation of the specific machine delivered, safety procedures, and maintenance of the equipment purchased. This training is completed at the time of delivery of their Tiger product. Tiger also provides a unique and value-added service, Tiger Mower Operator Safety Training (TMOST), which is available to all customers in the US and Canada and is led by a Tiger certified, OSHA authorized, and National Association of Safety Professionals (NASP) certified Safety Training/Planning Specialist. (This training does have an additional cost). (TMOST) training includes hands-on operations and covers all aspects of mowers and mowing problems and solutions while keeping the operator and the general public safe. This specific training is done onsite at a dealer location and usually is an all-day course.
39	Describe any technological advances that your proposed products or services offer.	Tiger has been a leader in right-of-way roadside mowing equipment and vegetation management equipment for over 53 years. However, even though Tiger was the first company to invent and engineer the patented hydraulic-powered side mount rotary mower, we have not rested on our laurels. One of our newest technological advances has been the introduction of our Boom Positioning system. Precisely engineered to control the boom arm movement from the operator seat with a simple flip of a switch. This puts the boom arm into the rear stow for a perfect fit every time. Tiger has updated and improved our hydraulic mower system to be entirely independent of the tractors' hydraulic system. We have developed an electronic hydraulic float system (EFS) for our Wildkat boom mowers, which enables the mower head to follow the contour of the ground while mowing. Tiger is the first company to build a boom mower designed to meet the legal transport height and width restrictions when loaded on a trailer, increasing customer safety in transport. Additionally, the design utilizes a unique break-away boom arm to improve the protection of boom components. With new technology and design leading our company and the industry, Tiger has been a leader in the past and will continue to build the best-built mowing products in the future.
40	Describe any "green" initiatives that relate to your company or to your products or services, and include a list of the certifying agency for each.	As an Alamo Group company, Tiger Corporation is a strong believer in Environmentally Sustainable practices and being a good steward of our environment. We have implemented a single-stream recycling program throughout our facility. Approximately 4 years ago, we implemented a reusable packaging program where we take our used cardboard boxes, shred them and reuse these for packing parts for shipment to our dealers and customers. We have updated the lighting throughout our facility to utilize (LED Lights) to lower wattage requirements and reduce our electricity needs. A majority of our design process is done with computer modeling, hence reducing the need for paper. Tiger undertook a massive engineering program to design its products to ensure compatibility of our products with Final Tier 4 & Stage 5 agricultural tractor designs, enabling our customers to use the latest technology and to reduce carbon emissions. We have transitioned from using calcium chloride to "Beet Juice" for liquid ballast, this transition providing our customers with an environmentally friendly fluid to add to their tractor tires for weight and stability. Beet Juice or also known as Rim Guard is Non-toxic, bio-degradable, water-soluble and the heaviest non-corrosive liquid ballast on the market! Please see the attached Sustainability Reports which are uploaded to the "Additional Documents Folder."
41	Identify any third-party issued eco-labels, ratings or certifications that your company has received for the equipment or products included in your Proposal related to energy efficiency or conservation, life-cycle design (cradle-to-cradle), or other green/sustainability factors.	Tiger transitioned from using calcium chloride to "Beet Juice" for liquid tire ballast. Beet Juice, also known as Rim Guard is Non-toxic, bio-degradable, water-soluble, and will never corrode tractor rims. Rim Guard SDS Sheets are uploaded to the "Additional Documents Folder." Tiger also uses Mobile Oil EAL 224H on certain model boom mowers. Mobile EAL 224H features and benefits, pictures of the label on Mobile EAL 224H Oil Canister, and SDS sheets are uploaded to the "Additional Documents Folder."
42	Describe any Women or Minority Business Entity (WMBE), Small Business Entity (SBE), or veteran owned business certifications that your company or hub partners have obtained. Upload documentation of certification (as applicable) in the document upload section of your response.	Tiger Corporation is a wholly-owned subsidiary of Alamo Group Inc., a public company listed on the NYSE (ALG) There are no special accreditations for Tiger Corporation at this time.
43	What unique attributes does your company, your products, or your services offer to Sourcwell participating entities? What makes your proposed solutions unique in your industry as it applies to Sourcwell participating entities?	With 53 years in the right-of-way roadside mowing equipment business, we have significant experience in developing, selling, and supporting industrial-strength roadside mowers. As an Alamo Group company, we have a significant number of engineering and product support resources to draw from, along with our strong financial strength. Tiger has a vast product offering within our product portfolio for the Sourcwell member to choose from and to enable them to have a one-stop shopping experience to satisfy their mowing needs. Another key attribute that Tiger provides to the Sourcwell customer is the breadth of our dealer channel with 57 dealer organizations and 260 locations. Tiger offers a sizeable top-of-the-line sales team trained and experienced in governmental sales. As a result, Tiger has one of the largest dealer organizations reaching and supporting the governmental market. The Tiger mowing system was designed with versatility in mind. Our customers have the ability to interchange several different mowing heads for the same boom mower. We have flail heads, rotary heads, mulching heads, and a ditcher that can be interchanged on the same unit. Our unique frame design allows our customers to change from a side mower to a boom mower in approximately 4 hours or less, reducing the cost of operation and allowing our customers to utilize that specific asset year-round. Tiger is a solutions-focused organization. We take the time to listen to our customers and discuss their mowing and road maintenance needs before ever recommending a product. Tiger believes in world-class customer support and ensuring that each customer is trained on our products after delivery; our field teams and dealers both provide this service.

DocuSign Envelope ID: 84D53BCE-B0C8-4958-99A8-7B4B5EEEE084

Table 9: Warranty

Describe in detail your manufacturer warranty program, including conditions and requirements to qualify, claims procedure, and overall structure. You may upload representative samples of your warranty materials (if applicable) in the document upload section of your response in addition to responding to the questions below.

Line Item	Question	Response *
44	Do your warranties cover all products, parts, and labor?	Yes, Tiger has a 1-year standard warranty on all products. This is listed in the Tiger Standard Warranty Policy that is included in the "Warranty " documents area.
45	Do your warranties impose usage restrictions or other limitations that adversely affect coverage?	There are no restrictions to any governmental entities. Tiger works directly with our customers to explain the warranty and what it covers at the time of purchase. Tiger Corporation also offers our customers the opportunity to purchase an extended warranty for up to 5 years.
46	Do your warranties cover the expense of technicians' travel time and mileage to perform warranty repairs?	Tiger will cover transportation costs on a product needed for repair for the first 60 days. Limited coverage for 1 year after purchase. If unique circumstances require assistance, Tiger works with our customers in covering this cost on a case-by-case basis.
47	Are there any geographic regions of the United States or Canada (as applicable) for which you cannot provide a certified technician to perform warranty repairs? How will Sourcwell participating entities in these regions be provided service for warranty repair?	Every region in North America will be serviced by a Tiger Authorized Dealer. Service, as well as warranty repair, is provided through the nearest Tiger Authorized Dealer.
48	Will you cover warranty service for items made by other manufacturers that are part of your proposal, or are these warranties issues typically passed on to the original equipment manufacturer?	All warranties will be covered by Tiger Corporation with the exception of tractor warranties. As a business partner with New Holland, John Deere, and Case IH tractors, these OEM manufacturers provide warranty and product support for all tractor related repairs.
49	What are your proposed exchange and return programs and policies?	Depending upon the situation the customer will work directly with the Tiger Authorized Dealer for exchanges and return items. Tiger provides a limited number of rebuilt components and Dealers may return parts and whole goods in new and unused condition for full credit.
50	Describe any service contract options for the items included in your proposal.	Tiger offers a one (1) year standard warranty on all products. This factory warranty covers any failure that happens under normal conditions. All Tiger products are eligible to receive an extended warranty, ranging from 1 to 5 years depending upon customer preference. Numerous Tiger dealers will offer service/maintenance programs to the end-users depending upon the customer preference.

Table 10: Payment Terms and Financing Options

Line Item	Question	Response *
51	Describe your payment terms and accepted payment methods?	Tiger policy allows Net 45 day payment terms. Exceptions can be made to this for special circumstances prior to acceptance of order. Bank Checks, ACH Transfers, and Wire Transfer are accepted as payment options.
52	Describe any leasing or financing options available for use by educational or governmental entities.	Tiger Corporation has been working directly with (NCL) National's Cooperative Leasing for the last 3 years. When a customer inquires about financing or governmental leases, we refer them to NCL. This relationship has benefited many of our Sourcwell/Tiger customers. NCL sample documents from the Tiger website are uploaded to the "Additional Documents" folder.
53	Briefly describe your proposed order process. Include enough detail to support your ability to report quarterly sales to Sourcwell as described in the Contract template. For example, indicate whether your dealer network is included in your response and whether each dealer (or some other entity) will process the Sourcwell participating entities' purchase orders.	Tiger ensures that the ordering process through the Sourcwell Contract is easy and pain-free for the end-user/ customer! Every order will be sent to Tiger Corporation by either the Tiger dealer, Tiger field manager or purchasing entity through email or fax. All purchase orders from the customer are made out to Tiger Corporation. Tiger verifies every Sourcwell order includes the membership number and all appropriate customer information. Next, the order is checked for accuracy & compatibility. Orders are transferred from the individual Sourcwell specific quote sheets and processed by our order fulfillment specialist at our factory. When the order is internally entered into our business system, it is transitioned into a work order in our company manufacturing software for building that specific product for the customer. We create an order code specific to the Sourcwell contract and then enter that information into Tiger's operating business system to assure all orders are tracked accordingly, and quarterly reports are processed in a timely manner for payment to Sourcwell. Once the order is placed in the system, our team is able to track from the first entry in our production system to completion and ship date. Tiger's accounting team, with direction from Tiger management, will track all Sourcwell orders and accrue the fees accordingly. The accounting office will submit the required quarterly reports. Accuracy in record keeping is a key strength of Tiger's accounting team as we manage 23 state contracts as well as supporting our dealers. Per Company policy the customer cannot be billed until the completed unit is delivered and accepted by the customer. Tiger's Authorized Dealer network is educated in the delivery of contract sales and aids in the order processing, delivery, and payment processing, working directly with the customer. In this manner, the customer receives their finished product on time, and Tiger maintains accurate records of the complete order fulfillment process. In summary, Tiger's goal is to ensure an easy ordering process and a positive customer experience for each Sourcwell member that does business with our company. Tiger will ensure accurate record-keeping for all Sourcwell orders and prompt payment of the contract fee.
54	Describe any standard transaction documents that you propose to use in connection with an awarded contract (order forms, terms and conditions, service level agreements, etc.). Upload a sample of each (as applicable) in the document upload section of your response.	Tiger uses contractual Sourcwell specific quote sheets that make placing an order simple and effective for our customers and dealers. Just type in the quantity of the product you would like, and the form calculates the discount off of list price and tabulates the total at the bottom of the page. We include the warranty paperwork with every order and a copy of the invoice along with instructions to call Tiger Corporation if there are any questions on the purchase or product itself. A sample quote sheet has been uploaded to the "Marketing Plan Documents."
55	Do you accept the P-card procurement and payment process? If so, is there any additional cost to Sourcwell participating entities for using this process?	Tiger currently does not accept P-cards, only because we have not had the need to do so. Tiger can certainly set up and receive P-cards, and would not charge any additional costs to Sourcwell members. Tiger can and routinely accepts wire transfers and ACH payments for ease of conducting business.

DocuSign Envelope ID: 84D53BCE-B0C8-4958-99A8-7B4B5EEEE084

Table 11: Pricing and Delivery

Provide detailed pricing information in the questions that follow below. Keep in mind that reasonable price and product adjustments can be made during the term of an awarded Contract as described in the RFP, the template Contract, and the Sourcwell Price and Product Change Request Form.

Line Item	Question	Response *
56	Describe your pricing model (e.g., line-item discounts or product-category discounts). Provide detailed pricing data (including standard or list pricing and the Sourcwell discounted price) on all of the items that you want Sourcwell to consider as part of your RFP response. If applicable, provide a SKU for each item in your proposal. Upload your pricing materials (if applicable) in the document upload section of your response.	Tiger Corporation has a standard list price on all our products. All Sourcwell members will receive an 18% discount on each line item from Tiger List prices. Prices are FOB destination. Tiger Corporation manufactures and sells side and twin rotary mowers, side, twin, rear, and triple flail mowers, boom mowers with reaches from 18 to 30 feet, along with 15 different attachment heads for these boom mowers. Tiger will supply Sourcwell, the Tiger Authorized Dealer, and the Sourcwell member with a Sourcwell specific interactive quote sheet to order products and a copy of the Sourcwell-Tiger Price List. Sourcwell Price List has been uploaded to the "Pricing Documents" folder.
57	Quantify the pricing discount represented by the pricing proposal in this response. For example, if the pricing in your response represents a percentage discount from MSRP or list, state the percentage or percentage range.	Tiger will offer an 18% discount on all Tiger List prices. A Sourcwell specific interactive quote sheet is provided for ease of ordering. A copy of the complete Sourcwell-Tiger Quote Sheets has been uploaded to the "Additional Documents" folder.
58	Describe any quantity or volume discounts or rebate programs that you offer.	Tiger offers an additional 2% discount on any order with three (3) units or more on the same order.
59	Propose a method of facilitating "sourced" products or related services, which may be referred to as "open market" items or "nonstandard options". For example, you may supply such items "at cost" or "at cost plus a percentage," or you may supply a quote for each such request.	Tiger will offer cost plus 12% on material costs and any additional labor charges for any 'sourced', 'open market' or non-standard options, and any applicable freight costs.
60	Identify any element of the total cost of acquisition that is NOT included in the pricing submitted with your response. This includes all additional charges associated with a purchase that are not directly identified as freight or shipping charges. For example, list costs for items like pre-delivery inspection, installation, set up, mandatory training, or initial inspection. Identify any parties that impose such costs and their relationship to the Proposer.	Tiger publishes all costs of acquiring a Tiger product in our list price, minus discount. Tiger does not surprise our customers with hidden costs. Once we are assured we have the right piece of equipment to match our customer's needs, all charges are upfront and shown on our quote sheet. All labor and delivery are included in the sales price. When dealer PDI is required, it is added to the specific quote sheet and the cost is listed on the price list.
61	If freight, delivery, or shipping is an additional cost to the Sourcwell participating entity, describe in detail the complete freight, shipping, and delivery program.	All Tiger products on the Sourcwell contract are listed freight, FOB Destination in the continental United States. Ocean freight charges will be added on sales to Alaska and Hawaii and external US territories. These additional freight costs will be listed on the Sourcwell specific quote sheet at the time of sale.
62	Specifically describe freight, shipping, and delivery terms or programs available for Alaska, Hawaii, Canada, or any offshore delivery.	Tiger would quote the products FOB Sioux Falls, SD, and would assist in arranging freight and documentation to Alaska, Hawaii, and any other offshore entity. For orders to Canada, Tiger will quote FOB Sioux Falls and arrange to add any additional surcharges, or customs charges to the bottom of our quote sheet for transparency to our customers.
63	Describe any unique distribution and/or delivery methods or options offered in your proposal.	Tiger coordinates all shipments for its products from our facility in Sioux Falls, SD. Delivery can be made to the nearest dealer location or to the customer's location. If a Tiger Dealer receives the goods, they will prep the equipment for delivery and deliver it to the customer location. If goods are shipped to the customer location, the Tiger dealer will schedule a time and date for product walk-around on the operation and key points on safety and daily maintenance of the Tiger product. We are very flexible in our delivery abilities and can accommodate any customer requirements.

Table 12: Pricing Offered

Line Item	The Pricing Offered in this Proposal is: *	Comments
64	c. better than the Proposer typically offers to GPOs, cooperative procurement organizations, or state purchasing departments.	Sourcwell pricing is the most cost effective way to procure Tiger Products.

DocuSign Envelope ID: 84D53BCE-B0C8-4958-99A8-7B4B5EEEE084

Table 13: Audit and Administrative Fee

Line Item	Question	Response *
65	Specifically describe any self-audit process or program that you plan to employ to verify compliance with your proposed Contract with Sourcwell. This process includes ensuring that Sourcwell participating antities obtain the proper pricing, that the Vendor reports all sales under the Contract each quarter, and that the Vendor remits the proper administrative fee to Sourcwell.	<p>Tiger understands the importance of accurate information on all paperwork and the value of an audit. At each phase of the order process our Tiger team will check and verify all information placed on the Sourcwell specific quote and call the customer if any questions arise. Again when the order moves to the floor to set up ship dates, Tiger will check the order for clarity, and again the customer will be called if there are any questions. All Tiger sales order team members know that compliance to pricing and exact ship to and bill to information is critical.</p> <p>After the sales order has gone through final review, the Tiger accounting department will monitor until ship/invoice is complete and reconcile all payments to the dealer and the Sourcwell fees. A report is written each month by our IT department to accumulate all contract sales, and Sourcwell contract sales would be added to this report. Submittal of fees are paid at the end of each fiscal quarter. Alamo Group has an internal audit team that assists Tiger with the audit procedure to assure that validity and adherence to contract specifics are administered correctly.</p>
66	If you are awarded a contract, provide a few examples of internal metrics that will be tracked to measure whether you are having success with the contract.	<p>Tiger has a fully automated internal computer system and software designed to track and monitor all sales by contract on a monthly basis. Since our awarded contract in 2017, 25% of Tiger's total sales have come from the Sourcwell contract.</p>
67	Identify a proposed administrative fee that you will pay to Sourcwell for facilitating, managing, and promoting the Sourcwell Contract in the event that you are awarded a Contract. This fee is typically calculated as a percentage of Vendor's sales under the Contract or as a per-unit fee; it is not a line-item addition to the Member's cost of goods. (See the RFP and template Contract for additional details.)	<p>Tiger Corporation would propose a 1% fee of total sales through this contract, that would be paid to Sourcwell for facilitating, managing, educating, and promoting this contract.</p>

DocuSign Envelope ID: 84D53BCE-B0C8-4958-99A8-7B4B5EEEE084

Table 14A: Depth and Breadth of Offered Equipment Products and Services

Line Item	Question	Response *
68	Provide a detailed description of the equipment, products, and services that you are offering in your proposal.	<p>Tiger Corporation offers a complete line of right-of-way roadside maintenance equipment. Starting with our top-of-the-line Boom Mowers (18 models), roadside shoulder mowers, rotary (5 models), and flail type mowers (6 models). Tiger also manufactures rear mowers (5 models), side shift rear mowers (8 models), along with multiple attachments to meet all our customer's needs.</p> <p>Tigers' boom mowers have reaches that extend from 13' to 30' in lengths. Our most popular boom cutter heads are the rotary and flail heads. These heads come in several sizes and offer multiple cutter knife combinations. We also have several different boom head attachments like the ditcher head, mulching head, sweeper head, 48" saw blade, Snow Panther snow blower head, excavator head, and JCB hydradig head, to name a few.</p> <p>Tiger manufactures a very efficient roadside shoulder mower for the industrial market. These rotary mowers are offered in either 60" or 72" cutting widths, with several blades to choose from, providing a flexible working solution for the customer. These models are also available in a twin configuration, which gives the customer a more expansive mowing capacity.</p> <p>One of Tigers' top-selling attachments is the Ditcher. With a 22" diameter cutting width, the Tiger rotary ditcher can move large amounts of dirt and mud from existing ditches or can cut a new path to create water flow and erosion control. This head is built with three heat-treated, self-sharpening, replaceable blades and wear plates.</p> <p>Tiger's flail mowers are offered as a single side, twin, rear, or triple flail configuration. Our flail mowers are some of the most durable and best-built mowers in the industry. We also offer a full line of 3 point flail mowers and pull-type triple flail mowers.</p> <p>Tiger offers rear rotary mowers that have cutting widths from 8' to 20'. An option to the rear rotary mower is the Offset Hitch which allows the tractor to remain on the road while the mower is entirely in the ditch. This provides operator safety and comfort to mow steep ditches without the tractor leaving the road.</p> <p>A Tiger exclusive innovation is the TruckKat. Tiger developed a boom mower that attaches directly to the modified truck bed of a Ford F550 or M2 Freightliner, turning the truck into a mobile boom-type cutting machine. This machine can travel at road speeds and then stop and change over to a right-of-way mowing machine cutting grass and brush up to 6" in diameter.</p> <p>Tiger has also designed a RailKut model, similar to the Truckat equipped with rail gear. The RailKut will provide an easy solution for efficient vegetation management of rail roads throughout North America.</p> <p>Tiger has developed an independent engine-driven boom mower that attaches to popular wheel loader models. This concept provides a solution to increase the customers' wheel loader utilization, making the loader a productive year-round piece of equipment. Flexibility and interchangeability are a solution for budget-conscious entities.</p> <p>The Tiger WET KUT system can be added to any rotary or flail cutting head, transforming a standard cutting head into a total vegetation maintenance machine. With a precision application of herbicide to any plant or shrub, while mowing, vegetation can be chemically controlled.</p> <p>One of Tiger's many tractor attachments is the Claw. This patented piece of equipment reclaims lost material from being washed away from the roadside edge. The disc gang action of the 22" boron steel blades provides a system to recover lost shoulder material from the ditch, pulling gravel and sand back up on the roadway to use again for clean driving surfaces.</p> <p>Interchangeability is a feature Tiger integrates into a number of our mowing systems. Product interchangeability enables the customer to purchase one tractor with multiple mowing systems. This solution solves the problem of numerous mowing challenges with one purchase, saving the customer money.</p> <p>Tiger is a business partner with New Holland, John Deere, and Case IH tractor Companies. These relationships allow us to offer turnkey tractor/mower products priced reasonably to the customer. Tiger maintains a stock of these tractors, allowing for fast deliveries.</p> <p>Tiger's product line is designed and engineered as a complete right-of-way maintenance solution.</p>
69	Within this RFP category there may be subcategories of solutions. List subcategory titles that best describe your products and services.	<p>Industrial right-of-way mowing equipment, Tractor/Mower Attachments, Roadside Vegetation Management Equipment, Rotary and Flail side and rear mowers. Boom Mowers. Flex Wing Rotary Mowers.</p>

DocuSign Envelope ID: 84D53BCE-B0C8-4958-99A8-7B4B5EEEE084

Table 14B: Depth and Breadth of Offered Equipment Products and Services

Indicate below if the listed types or classes of equipment, products, and services are offered within your proposal. Provide additional comments in the text box provided, as necessary.

Line Item	Category or Type	Offered *	Comments
70	Flail, boom, rotary, wing, sickle, and slope mowers	<input checked="" type="radio"/> Yes <input type="radio"/> No	Tiger specializes in manufacturing side rotary and flail mowers along with booms mowers from 13 to 30' reach with multiple head combinations.
71	Seeders, tillers, mulchers, and sprayers	<input checked="" type="radio"/> Yes <input type="radio"/> No	Tiger offers a boom mulcher head and a wet cut system that allows our customers to apply herbicide.
72	Erosion control equipment	<input checked="" type="radio"/> Yes <input type="radio"/> No	Many of Tiger's products are considered erosion control: Ditchers, Wetcut system, and the Claw roadside reclaimer. Our Ditchers allow water to flow freely in drainage ditches to reduce water backing up and causing floods or erosion outside of the ditch banks. The Claw is a one-way disk that helps reclaim gravel that is washed away by spring rain or removal of shoulder material caused by a snow plow. The Wetcut is a herbicide bar that allows for chemical management of noxious weeds rather than using tillage to control weeds.
73	Ditch maintenance equipment	<input checked="" type="radio"/> Yes <input type="radio"/> No	Tiger offers a boom ditcher head along with a complete ditcher system for any tractor.
74	Signage, signals, and message boards	<input checked="" type="radio"/> Yes <input type="radio"/> No	N/A
75	Radar equipment, traffic cameras or traffic sensors	<input checked="" type="radio"/> Yes <input type="radio"/> No	N/A
76	Other road right-of-way maintenance equipment	<input checked="" type="radio"/> Yes <input type="radio"/> No	Tiger offers a Truckat boom mowing system, Wheel Loader boom mower and multiple other rear three point tractor boom or flail mowers. We have had excellent success with the Truckat in the market place as it is an F550 chassis with our 22 ft. Bengal or 24 ft. Bengal boom mower installed on the chassis. Our Wheel Loader boom mowing system allows our customers to better utilize their capital investment of a payloader when not loaded gravel or salt trucks in the off season.

Table 16: Exceptions to Terms, Conditions, or Specifications Form

Line Item 77. NOTICE: To identify any exception, or to request any modification, to the Sourcwell template Contract terms, conditions, or specifications, a Proposer must submit the exception or requested modification on the Exceptions to Terms, Conditions, or Specifications Form immediately below. The contract section, the specific text addressed by the exception or requested modification, and the proposed modification must be identified in detail. Proposer's exceptions and proposed modifications are subject to review and approval of Sourcwell and will not automatically be included in the contract.

Contract Section	Term, Condition, or Specification	Exception or Proposed Modification
		No exceptions needed.

Documents

Ensure your submission document(s) conforms to the following:

1. Documents in PDF format are preferred. Documents in Word, Excel, or compatible formats may also be provided.
2. Documents should NOT have a security password, as Sourcwell may not be able to open the file. It is your sole responsibility to ensure that the uploaded document(s) are not either defective, corrupted or blank and that the documents can be opened and viewed by Sourcwell.
3. Sourcwell may reject any response where any document(s) cannot be opened and viewed by Sourcwell.
4. If you need to upload more than one (1) document for a single item, you should combine the documents into one zipped file. If the zipped file contains more than one (1) document, ensure each document is named, in relation to the submission format item responding to. For example, if responding to the Marketing Plan category save the document as "Marketing Plan."

DocuSign Envelope ID: 84D53BCE-B0C8-4958-99A8-7B4B5EEEE084

- Pricing - 1 - Pricing Documents.zip - Friday July 02, 2021 12:14:34
- Financial Strength and Stability - 2 - Finance Strength and Stability Documents.zip - Wednesday June 30, 2021 10:57:11
- Marketing Plan/Samples - 3 - Marketing Plans Documents.zip - Friday July 02, 2021 12:23:34
- WMBE/MBE/SBE or Related Certificates (optional)
- Warranty Information - Tiger_Limited_Warranty.pdf - Tuesday June 08, 2021 09:56:03
- Standard Transaction Document Samples (optional)
- Upload Additional Document - 7 - Upload Additional Documents.zip - Friday July 02, 2021 12:25:15

DocuSign Envelope ID: 84D53BCE-B0CB-4958-99A8-7B4B5EEEE084

Addenda, Terms and Conditions**PROPOSER AFFIDAVIT AND ASSURANCE OF COMPLIANCE**

I certify that I am the authorized representative of the Proposer submitting the foregoing Proposal with the legal authority to bind the Proposer to this Affidavit and Assurance of Compliance:

1. The Proposer is submitting this Proposal under its full and complete legal name, and the Proposer legally exists in good standing in the jurisdiction of its residence.
2. The Proposer warrants that the information provided in this Proposal is true, correct, and reliable for purposes of evaluation for contract award.
3. The Proposer, including any person assisting with the creation of this Proposal, has arrived at this Proposal independently and the Proposal has been created without colluding with any other person, company, or parties that have or will submit a proposal under this solicitation; and the Proposal has in all respects been created fairly without any fraud or dishonesty. The Proposer has not directly or indirectly entered into any agreement or arrangement with any person or business in an effort to influence any part of this solicitation or operations of a resulting contract; and the Proposer has not taken any action in restraint of free trade or competitiveness in connection with this solicitation. Additionally, if Proposer has worked with a consultant on the Proposal, the consultant (an individual or a company) has not assisted any other entity that has submitted or will submit a proposal for this solicitation.
4. To the best of its knowledge and belief, and except as otherwise disclosed in the Proposal, there are no relevant facts or circumstances which could give rise to an organizational conflict of interest. An organizational conflict of interest exists when a vendor has an unfair competitive advantage or the vendor's objectivity in performing the contract is, or might be, impaired.
5. The contents of the Proposal have not been communicated by the Proposer or its employees or agents to any person not an employee or legally authorized agent of the Proposer and will not be communicated to any such persons prior to Due Date of this solicitation.
6. If awarded a contract, the Proposer will provide to Sourcwell Participating Entities the equipment, products, and services in accordance with the terms, conditions, and scope of a resulting contract.
7. The Proposer possesses, or will possess before delivering any equipment, products, or services, all applicable licenses or certifications necessary to deliver such equipment, products, or services under any resulting contract.
8. The Proposer agrees to deliver equipment, products, and services through valid contracts, purchase orders, or means that are acceptable to Sourcwell Members. Unless otherwise agreed to, the Proposer must provide only new and first-quality products and related services to Sourcwell Members under an awarded Contract.
9. The Proposer will comply with all applicable provisions of federal, state, and local laws, regulations, rules, and orders.
10. The Proposer understands that Sourcwell will reject RFP proposals that are marked "confidential" (or "nonpublic," etc.), either substantially or in their entirety. Under Minnesota Statutes Section 13.591, subdivision 4, all proposals are considered nonpublic data until the evaluation is complete and a Contract is awarded. At that point, proposals become public data. Minnesota Statutes Section 13.37 permits only certain narrowly defined data to be considered a "trade secret," and thus nonpublic data under Minnesota's Data Practices Act.
11. Proposer its employees, agents, and subcontractors are not:
 1. Included on the "Specially Designated Nationals and Blocked Persons" list maintained by the Office of Foreign Assets Control of the United States Department of the Treasury found at: <https://www.treasury.gov/ofac/downloads/sdnlist.pdf>;
 2. Included on the government-wide exclusions lists in the United States System for Award Management found at: <https://sam.gov/SAM/>; or
 3. Presently debarred, suspended, proposed for debarment, declared ineligible, or voluntarily excluded from programs operated by the State of Minnesota; the United States federal government or the Canadian government, as applicable; or any Participating Entity. Vendor certifies and warrants that neither it nor its principals have been convicted of a criminal offense related to the subject matter of this solicitation.

By checking this box I acknowledge that I am bound by the terms of the Proposer's Affidavit, have the legal authority to submit this Proposal on behalf of the Proposer, and that this electronic acknowledgment has the same legal effect, validity, and enforceability as if I had hand signed the Proposal. This signature will not be denied such legal effect, validity, or enforceability solely because an electronic signature or electronic record was used in its formation. - Shawn Cleary, President, Tiger Corporation

The Proposer declares that there is an actual or potential Conflict of Interest relating to the preparation of its submission, and/or the Proposer foresees an actual or potential Conflict of Interest in performing the contractual obligations contemplated in the bid.

Yes No

The Bidder acknowledges and agrees that the addendum/addenda below form part of the Bid Document.

Bid Number: RFP 070821

Vendor Name: Tiger Corporation

DocuSign Envelope ID: 84D53BCE-B0C8-4958-99A8-7B4B5EEEE084

Check the box in the column "I have reviewed this addendum" below to acknowledge each of the addenda.

File Name	I have reviewed the below addendum and attachments (if applicable)	Pages
Addendum_4_Road_ROW_Maintenance_Eqpt_RFP_070821 Fri June 18 2021 05:04 PM	<input checked="" type="checkbox"/>	1
Addendum_3_Road_ROW_Maintenance_Eqpt_RFP_070821 Thu June 17 2021 06:20 PM	<input checked="" type="checkbox"/>	1
Addendum_2_Road_ROW_Maintenance_Eqpt_RFP_070821 Wed June 16 2021 05:21 PM	<input checked="" type="checkbox"/>	1
Addendum_1_Road_ROW_Maintenance_Eqpt_RFP_070821 Wed May 26 2021 04:28 PM	<input checked="" type="checkbox"/>	1

Bid Number: RFP 070821

Vendor Name: Tiger Corporation

**AMENDMENT
TO
CONTRACT #070821-TGR**

THIS AMENDMENT is effective upon the date of the last signature below by and between **Sourcewell and Tiger Corporation (Supplier)**.

Sourcewell awarded a contract to Supplier to provide Road Right-of-Way Maintenance Equipment to Sourcewell and its Participating Entities, effective August 6, 2021, through August 9, 2025 (Contract).

The parties wish to amend the Contract to add:

For sales in Canada, Participating Entities will contact Supplier's Canadian Dealers to place orders. Supplier will ensure that a current list of Canadian Dealers is maintained with Sourcewell. Tiger's Canadian Dealers will invoice Participating Entities directly in Canadian dollars.

Except as amended by this Amendment, the Original Agreement remains in full force and effect.

Sourcewell

DocuSigned by:
By: Jeremy Schwartz
C0FD2A139D06489...
Jeremy Schwartz, Director of Operations/CPO

Date: 6/14/2022 | 8:21 PM CDT

Approved:

DocuSigned by:
By: Chad Coquette
7E4298F817A64CC...
Chad Coquette, Executive Director/CEO

Date: 6/14/2022 | 9:59 PM CDT

Tiger Corporation

DocuSigned by:
By: Shawn Cleary
AEE88DAB908641C...
Shawn Cleary, President

Date: 6/14/2022 | 2:35 PM CDT

**RESOLUTION
#3**

Resolution No. _____ of 2022, a resolution authorizing acceptance of the Settlement Agreement and Full and Final Release of Claims from Selective Insurance for the fire loss to Town property on August 17, 2021.

Introduced by _____, who moved its adoption, seconded by _____.

WHEREAS, on August 17, 2021, an accidental fire occurred and caused severe damage to the facility locally known as the "White Building", which was used primarily by the Highway Department, and

WHEREAS, the "White Building" was insured against property, fire and casualty losses through Selective Insurance Policy # S1801921, which includes replacement value coverage for the structure, and

WHEREAS, by Resolution No. 20 Of 2022, the Highway Superintendent, Dahn Bull was authorized to notify Selective Insurance of the Town's intent to accept Select Insurance's estimate of recoverable depreciation of the structure, and to begin planning, designing, and preparing bid documents for the construction of a new, modern garage facility for the Highway Department, on Highway Department property, and

WHEREAS, pursuant to a letter to the Town of Clifton Park dated September 29, 2022, Selective Insurance has agreed to an "overall settlement in the amount of \$1,126,146.75... per verbal discussion...in exchange for a policy release", and

WHEREAS, the Highway Superintendent wishes to accept the final settlement payment in the amount of \$250,737.50; now, therefore, be it

RESOLVED, that the Superintendent of Highways is authorized to notify Selective Insurance of the Town's intent to accept the final payment of \$250,737.50 and be it further

RESOLVED, that the Supervisor is authorized to sign Selective Insurance's Settlement Agreement and Full and Final Release of Claim.

Meg Springli

From: noreply
Sent: Tuesday, October 4, 2022 11:50 AM
To: Meg Springli
Cc: Jean, Spiegel; Mark Heggen; Tom McCarthy
Subject: Resolution Request for TB Meeting: 10-11-2022 Highway Department
Attachments: 633c56406705a-Backup for White Building Insurance Resolution.pdf

An item has been submitted to the Resolution Request form for review.

Department: **Highway Department**
Your email: **dbull@cliftonpark.org**

Sponsor/Contact as shown on the agenda (i.e. P. Barrett, A. Standaert, D. Bull, etc.): **D. Bull**

Requested Meeting Date: **10-11-2022**

Brief Description: **A resolution authorizing the Superintendent of Highways to sign the final payment letter for the White Building Fire of August 17, 2021.**

Budget #:
Budget Description: **Town General Fund**
\$ Amount: **\$250,737.50**

Additional Comments/Details:

COMPTROLLER APPROVAL or Comments:

ATTORNEY APPROVAL or Comments:



DAHN S. BULL
SUPERINTENDENT OF HIGHWAYS

Memo

To: The Clifton Park Town Board
From: Dahn S. Bull, Superintendent of Highways
cc: Ellen Martin, Deputy Highway Superintendent, Heather Schultz, Clerk, Mark Heggen, Comptroller, Tom McCarthy Town Attorney
Date: October 3, 2022
Re: Final Payment and Letter – Fire of White Building, August 17, 2021

We have concluded the insurance claim with our Insurance Company, Amsure and its larger partner Selective. Working with our Insurance Representative, David Meager, we have come to an agreement to finalize the loss claim from the White Building fire from August 17, 2021.

Selective and the Highway Department have agreed to settle the above referenced claim for the Compromised Full and Final total claim amount of \$1,126,146.75. From this total, \$250,737.50 remains to be released. In exchange for a signing of a Policyholder Release (attached) and thus closing out the insurance claim, the quarter million will be released to the Town.

To-date, Selective has paid a total of \$875,409.25 which leaves a remaining balance of \$250,737.50 due upon receipt of the Executed Release. I have attached a Statement of Loss breaking down all claim payment made for your reference. We have agreed to the following items in an effort to reach this final settlement:

In this proposal, the last remaining funds of the \$250,737.50 would be paid to the Town. Selective agrees to pay out a total settlement of \$118,466.53 towards future engineering expenditures in the construction of a new facility at the Highway Department.

Additionally, Selective agrees to a salvage deduction on the garage awning (Resolution 286 of 2021) bringing the final total to \$62,940. Overall, the project was a total of \$105,867.15, which was \$967.15 over the bid amount from the original resolution.

To release the above along with the available Building "Recoverable Depreciation", in the amount of \$69,330.97 in exchange for the Executed Release. This amount was mentioned in a previous resolution passed by the Town Board, Resolution 20 of 2022.

I am asking the Town Board to pass a resolution authorizing me to sign, and have notarized by the Town Clerk, the attached Policyholder Release and email the Executed Copy back to our Representative, David Meager, and his counterpart at Selective, Chris Kennedy. Once the executed copy is signed and in the possession of the Insurance company, they will release the \$250,737.50 of the remaining balance to finalize the claim.

While the process was time consuming and led to a lot of research on our behalf, we worked incredibly well with Mr. Meager and his team at Amsure and Selective. If you have any questions please reach out.

SELECTIVE

BE UNIQUELY INSUREDSM

Christopher Kennedy
Selective Insurance Company of America
Mailing address for correspondence:
PO Box 7264
London, KY 40742
Phone#: 518-598-5165
Fax#: 877-233-0917
Christopher.Kennedy@selective.com

September 29, 2022

Town of Clifton Park
1 Town Hall Plz
Clifton Park, NY 12065

RE: Insured: Town of Clifton Park
Claim#: 22254510
D/L: 08/17/2021
Insurance Company: Selective Insurance Company of New York

Dear Mr. Bull,

This letter is a follow-up to our discussion regarding a verbal agreement to settle this claim via an agreed compromised overall settlement in the amount of \$1,126,146.75. As per our verbal discussion, we have agreed to this compromised overall claim settlement total in exchange for a policyholder release. Please find the enclosed Policyholder Release accordingly and return it to our office. Once we have received the signed, notarized policyholder release, we will release the remaining balance of the agreed compromised settlement in the amount of \$250,737.50. The payment will be sent to the address above in order to conclude the handling of this file.

If your mortgage company is included on your check, you will need to contact them to arrange for their endorsement. Please be sure that all parties named on the check endorse it prior to presenting it for payment.

Thank you for your cooperation and assistance throughout the handling of your claim. If you should happen to have questions concerning this claim settlement, please do not hesitate to contact this writer at 518-598-5165.

Sincerely,

Christopher Kennedy
Property General Adjuster
Selective Insurance Company of America

SETTLEMENT AGREEMENT AND FULL AND FINAL RELEASE OF CLAIM

This Settlement Agreement and Full and Final Release ("Agreement") of claims is made by and between Selective Insurance Company of New York (collectively "Selective") and Town of Clifton Park. These parties are referred to as the "Parties" herein.

IT IS HEREBY AGREED BETWEEN THE PARTIES AS FOLLOWS:

In consideration of the promises described herein, Selective agrees to the compromised overall claim settlement amount of One Million One Hundred Twenty Six Thousand One Hundred Forty Six Dollars and Seventy Five Cents (\$1,126,146.75).

The undersigned, Town of Clifton Park, hereby agrees to resolve by compromise and settlement, Full and Final release of Property claims, in exchange for any remaining balance due of the agreed overall claim settlement amount of One Million One Hundred Twenty Six Thousand One Hundred Forty Six Dollars and Seventy Five Cents (\$1,126,146.75) to be mailed to the aforementioned address.

In consideration for this payment, and subject to receipt of said payment, the Undersigned hereby releases and forever discharges Selective, and each of its servants, successors, heirs, assigns, subrogees, transferees, affiliates, shareholders, executors, administrators, officers, directors, employees, agents, claim representatives, investigators, attorneys and all other persons, firms, corporations, associations, partnerships or other entities representatives from any and all obligations of any kind under the policy number S1801921 issued to Town of Clifton Park related to the garage fire damage occurring on or about August 17, 2021 at the property located at Clifton Park Center Road, Clifton Park, NY 12065. This release includes, but is not limited to, (1) any claims for reimbursement of any payments that have been made or will be made in connection with the property loss claim, including, but not limited to, payments for replacement of the property, ordinance or law requirements, labor costs, lost income, loan payments, interest payments, diminution of value and all other claims, expenses or liabilities related to the claim, (2) any claims for reimbursement of attorneys' fees and/or litigation expenses that have been incurred or will be incurred by Town of Clifton Park, (3) any claims for reimbursement of attorneys' fees and/or litigation expenses that have been incurred or will be incurred by Town of Clifton Park; in connection with this case or any related claims, counterclaims, coverage claims, lawsuits or appeals.

In further consideration of the promises of Selective as described herein, "Town of Clifton Park" hereby releases, acquits and forever discharges Selective, and its agents, servants, successors, heirs, assigns, subrogees, transferees, affiliates, shareholders, executors, administrators, officers, directors, employees, insurers, attorneys, and all other persons, firms, corporations, associations, partnerships or other entities from any and all claims pertaining to Property under the Selective policy that could have been asserted by "Town of Clifton Park" in this case, whether such claims are known or unknown and

whether such claims have been asserted or are asserted in the future. This release is intended to fully excuse Selective from any and all insurance obligations pertaining to property with respect to the damages on the Selective policy in connection with any of the circumstances described in this property damage case.

The Undersigned hereby acknowledges that the payment described above is in full and completes settlement of all Property claims against Selective and the other Releasees designated herein, by reason of any loss or damage sustained to property located at Clifton Park Center Road, Clifton Park, NY 12065 caused by fire or otherwise, which occurred at that location on or about August 17, 2021 (Selective claim number 22254510), including, but not limited to, all claims for damages sustained..

The Undersigned further hereby agrees that the payment described above is made in compromise of the pending dispute with Selective, and is not an admission of liability as to the Undersigned's entitlement to receive the amount described above, nor an admission of liability for those amounts under the aforementioned insurance policy or otherwise. The Undersigned further understands and agrees that the sole purpose of the settlement of these matters is to fully resolve the pending Property claim.

The Undersigned further agrees to indemnify and hold the Releasees designated herein harmless, to the extent of the payment described above, against any and all claims and demands of any lienholder, contractor, public insurance adjuster or attorney.

The Undersigned acknowledges that he/she has read this Release and understands its provisions and agreements, and acknowledges that this Release has been voluntarily given by him, as the duly authorized representative of Town of Clifton Park without duress or coercion and after the Undersigned has had an opportunity to consult with Town of Clifton Park.

This agreement constitutes a single, integrated written contract, expressing the entire understanding and agreement between the parties, and that the terms of the agreement are contractual and not merely recitals. No other agreement, whether written or oral, expressed or implied, exists between the parties with respect to the subject matter of this agreement, and the Undersigned declares and represents that no promise, inducement, or other agreement not expressly contained in this agreement has been made conferring any benefit upon her.

It is further agreed that this Release shall be construed as if both parties jointly prepared it, and any uncertainty or ambiguity in the Release shall not be interpreted against any specific party.

It is understood and agreed that this is a comprehensive, full and final release of all Property claims against Selective which in any way relate to this loss or claim.

In signing this agreement, we further acknowledge that we have entered into it upon our own free will, and that we have not relied upon any promise, statement or representation

made by the Selective Insurance Company of New York, or any person claiming to represent it, except as set forth in this written document.

I/WE HAVE READ AND FULLY UNDERSTAND THIS FULL AND FINAL COMPLETE RELEASE OF ALL CLAIMS

Releasor(s) state(s) that Releasor(s) have/has read and fully understand the terms of this Policyholder Release of All Claims and sign the same as Releasor("s") own free and voluntary act on this the _____ day of _____, 2022.

Insured

IN WITNESS WHEREOF, the Undersigned has hereunto set her hand this _____ day of _____, 2022.

STATE OF NEW YORK)

(COUNTY OF _____)

Subscribed and sworn to before me
this ____ day of _____, 2022

NOTARY PUBLIC

_____, County, New York

My Commission Expires: _____

Claim #: 22254510

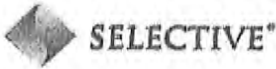

Statement of Loss
 DOL: 08/17/2021
 Claim 22254510
 Insured: Town of Clifton Park

Item	Policy Limit	Loss	Claim
Coverage Per Policy: 639 Clifton Park Center Rd. Clifton Park, NY 12085 Coverage Forms: CP 1030 and CP 7638 (disappearing deductible)			
Deductible: \$0 - Disappearing deductible / Mortgage/Loss Payee: Key Government Finance on Equipment			
Loss As Determined Per File:			
Building Limit:	\$ 32,536,293	blanket with bpp	
Xactimate Estimate - Selective - for demo and reconstruction			
Replacement Cost Valuation (RCV)		\$ 617,776.12	
Less Recoverable Depreciation		\$ 69,330.97	
Actual Cash Value		\$ 548,445.15	
Less Deductible:		\$ -	
Net Claim/Total Payment:		\$ 548,445.15	Paid to insured
BPP Limit	\$ 32,536,293	blanket with bpp	
PH Inventory Validated by RCF Salvage			
Replacement Cost Valuation (RCV)		\$ 44,659.89	
Less Depreciation		\$ 10,671.81	
Actual Cash Value		\$ 33,987.98	
Less Deductible:		\$ -	
Net Claim/Total Payment:		\$ 33,987.98	Paid
Unifirst - uniform replacement completed (invoice on file)		\$ 2,026.12	Paid
Contractors Equipment Limit:	limit per piece		
#109 - Elcin Broom Bear Sweeper	\$ 269,000.00		
Replacement Cost Valuation (RCV)-per Dealership where purchased		\$ 287,581.00	
Less Recoverable Depreciation		\$ -	No depreciation - machine only 5 months old at time of loss
Actual Cash Value		\$ 287,581.00	
Less amount over limit		\$ 18,581.00	
Net Claim/Total Payment:		\$ 269,000.00	Policy Limit Paid
#11 - 1997 Ford Tractor (will settle at ACV due to IM over 5 years)	\$ 32,868.00	\$ 16,950.00	ACV Paid
Over Limit Sweeper Rental while awaiting replacement (CM 71 14) - (\$19,520 is total for 2 week rental from Evolution Construction)	\$5,000	\$ 5,000.00	Policy Limit Paid
Payments to Date:	BLDG	BPP	IM
Total Payments to Date	\$ 548,445.15	\$ 36,014.10	\$ 290,950.00
TOTAL CLAIM PAYMENTS	\$ 875,409.25		

RESOLUTION
#4

Resolution No. _____ of 2022, a resolution authorizing Mohawk Towpath Byway to use town roadways for their Duathlon, on October 16th, 2022.

Introduced by _____, who moved its adoption, seconded by _____.

WHEREAS, Mohawk Towpath Byway has requested the use of Town of Clifton Park roadways, as specified in the attachment hereto, for the purpose of holding a Duathlon on Sunday, October 16th, 2022, from 8:30am until the last participant completes the course by 11am, and

WHEREAS, the event sponsors have coordinated with the town's Highway Superintendent for the safe use of town roads; now, therefore, be it

RESOLVED, that the Town Board hereby authorizes Mohawk Towpath Byway to use town roadways, as specified in the attachment hereto, October 16th, 2022 at 8:30AM, for the purpose of holding a Duathlon, and be it further

RESOLVED, that this approval is expressly conditioned upon the roads not being closed but employees of Mohawk Towpath Byway are permitted to temporarily stop traffic at each end of the course in the event both a vehicle and race participant arrive at the same time.

Meg Springli

From: noreply
Sent: Tuesday, October 4, 2022 11:01 AM
To: Meg Springli
Cc: Jean, Spiegel; Mark Heggen; Tom McCarthy
Subject: Resolution Request for TB Meeting: 10-11-2022 Highway Department
Attachments: 633c4a91d8998-Backup for REquest for Mohawk Byway Bike Event.pdf

An item has been submitted to the Resolution Request form for review.

Department: **Highway Department**
Your email: **dbull@cliftonpark.org**

Sponsor/Contact as shown on the agenda (i.e. P. Barrett, A. Standaert, D. Bull, etc.): **D. Bull**

Requested Meeting Date: **10-11-2022**

Brief Description: **A resolution allowing the Mohawk Towpath Byway Organization to use town roadways for a biathlon.**

Budget #: **NA**
Budget Description: **NA**
\$ Amount: **NA**

Additional Comments/Details: **Insurance Attached.**

COMPTROLLER APPROVAL or Comments:

ATTORNEY APPROVAL or Comments:

Dahn Bull

From: Barb and Eric Hamilton <ejh.bkh.hamilton@gmail.com>
Sent: Monday, September 26, 2022 2:49 PM
To: Dahn Bull
Subject: Mohawk Towpath Byway Duathlon
Attachments: 2014Run.jpg; 12MileBike.jpg; CERT-TownCP.pdf

Dan:

The Mohawk Towpath Byway would like to host a Duathlon at Riverview Orchards, 660 Riverview road the Morning of October 16. The event includes a two mile run, 12 mile of cycling and another two mile run to the finish. I attach:

- A map (2014run.jpg) shows the run west on Riverview and turn right onto Droms Road and turn at a one mile point;
- a map (12MileBike.jpg) shows the cycling course from Riverview Orchards east six miles to turn around at the loop just west of the Halfmoon Town Line, and
- A certificate of insurance from our sanctioning body (CERT-TownCP.pdf) naming the Town as an additional insured.

We anticipate as many as 150 participants and about 30 volunteers officiating and directing participants at intersections. We plan to accommodate early Sunday morning traffic. Volunteers on or near the roadway will be wearing highway safety vests. We expect to temporarily hold traffic for a limited time (several minutes) while we officially start the event in the middle of the highway at 8:30 AM. The event will be over by 11 AM.

Please contact me at 518-371-7548 if you need additional. During the event I can be reached at 518-810-4853 and race director Kristen Hislop can be reached at 518-577-5889.

--

Eric J. Hamilton
Mohawk Towpath Byway
P O Box 90
Clifton Park, N Y 12065
<http://www.mohawktowpath.org> and <https://bywayfriends.org>



CERTIFICATE OF LIABILITY INSURANCE

DATE (MM/DD/YYYY)

9/14/2022

THIS CERTIFICATE IS ISSUED AS A MATTER OF INFORMATION ONLY AND CONFERS NO RIGHTS UPON THE CERTIFICATE HOLDER. THIS CERTIFICATE DOES NOT AFFIRMATIVELY OR NEGATIVELY AMEND, EXTEND OR ALTER THE COVERAGE AFFORDED BY THE POLICIES BELOW. THIS CERTIFICATE OF INSURANCE DOES NOT CONSTITUTE A CONTRACT BETWEEN THE ISSUING INSURER(S), AUTHORIZED REPRESENTATIVE OR PRODUCER, AND THE CERTIFICATE HOLDER.

IMPORTANT: If the certificate holder is an ADDITIONAL INSURED, the policy(ies) must have ADDITIONAL INSURED provisions or be endorsed. If SUBROGATION IS WAIVED, subject to the terms and conditions of the policy, certain policies may require an endorsement. A statement on this certificate does not confer rights to the certificate holder in lieu of such endorsement(s).

PRODUCER Insurance Office of America, Inc. 1855 West State Road 434 Longwood FL 32750 License#: 0E67768 USATRIA-01	CONTACT NAME: PHONE (A/C, No, Ext): E-MAIL ADDRESS:	FAX (A/C, No):
	INSURER(S) AFFORDING COVERAGE	
INSURED USA Triathlon of Colorado 5825 Delmonico Dr Colorado Springs CO 80919	INSURER A: Everest National Insurance Company	NAIC# 10120
	INSURER B: United States Fire Insurance Company	21113
	INSURER C:	
	INSURER D:	
	INSURER E:	
	INSURER F:	

COVERAGES

CERTIFICATE NUMBER: 1886426524

REVISION NUMBER:

THIS IS TO CERTIFY THAT THE POLICIES OF INSURANCE LISTED BELOW HAVE BEEN ISSUED TO THE INSURED NAMED ABOVE FOR THE POLICY PERIOD INDICATED. NOTWITHSTANDING ANY REQUIREMENT, TERM OR CONDITION OF ANY CONTRACT OR OTHER DOCUMENT WITH RESPECT TO WHICH THIS CERTIFICATE MAY BE ISSUED OR MAY PERTAIN, THE INSURANCE AFFORDED BY THE POLICIES DESCRIBED HEREIN IS SUBJECT TO ALL THE TERMS, EXCLUSIONS AND CONDITIONS OF SUCH POLICIES. LIMITS SHOWN MAY HAVE BEEN REDUCED BY PAID CLAIMS.

INSR LTR	TYPE OF INSURANCE	ADDL SUBR INSD WVD	POLICY NUMBER	POLICY EFF (MM/DD/YYYY)	POLICY EXP (MM/DD/YYYY)	LIMITS	
A	<input checked="" type="checkbox"/> COMMERCIAL GENERAL LIABILITY <input type="checkbox"/> CLAIMS-MADE <input checked="" type="checkbox"/> OCCUR <input checked="" type="checkbox"/> Part. Legal Liab GEN'L AGGREGATE LIMIT APPLIES PER: <input type="checkbox"/> POLICY <input type="checkbox"/> PRO-JECT <input type="checkbox"/> LOC <input checked="" type="checkbox"/> OTHER: Event	Y Y	S18ML02108-211	12/1/2021	12/1/2022	EACH OCCURRENCE	\$ 1,000,000
						DAMAGE TO RENTED PREMISES (Ea occurrence)	\$ 1,000,000
						MED EXP (Any one person)	\$
						PERSONAL & ADV INJURY	\$ 1,000,000
						GENERAL AGGREGATE	\$ 2,000,000
						PRODUCTS - COMP/OP AGG	\$ 2,000,000
							\$
	AUTOMOBILE LIABILITY <input type="checkbox"/> ANY AUTO <input type="checkbox"/> OWNED AUTOS ONLY <input type="checkbox"/> HIRED AUTOS ONLY <input type="checkbox"/> SCHEDULED AUTOS NON-OWNED AUTOS ONLY 4077887833					COMBINED SINGLE LIMIT (Ea accident)	\$
						BODILY INJURY (Per person)	\$
						BODILY INJURY (Per accident)	\$
						PROPERTY DAMAGE (Per accident)	\$
							\$
A	<input type="checkbox"/> UMBRELLA LIAB <input checked="" type="checkbox"/> EXCESS LIAB DED RETENTION \$	Y Y	S18EX01473-211	12/1/2021	12/1/2022	EACH OCCURRENCE	\$ 10,000,000
						AGGREGATE	\$ 10,000,000
							\$
	WORKERS COMPENSATION AND EMPLOYERS' LIABILITY ANY PROPRIETOR/PARTNER/EXECUTIVE OFFICER/MEMBER EXCLUDED? (Mandatory in NH) If yes, describe under DESCRIPTION OF OPERATIONS below	Y/N N/A				PER STATUTE	OTH-ER
						E.L. EACH ACCIDENT	\$
						E.L. DISEASE - EA EMPLOYEE	\$
						E.L. DISEASE - POLICY LIMIT	\$
B	Participant Accident		US1708030	12/1/2021	12/1/2022	Accident Medical	25,000

DESCRIPTION OF OPERATIONS / LOCATIONS / VEHICLES (ACORD 101, Additional Remarks Schedule, may be attached if more space is required)
 Coverage applies to the USA Triathlon sanctioned or approved event specified on this certificate.

The certificate holder is an additional insured, where required by written contract or agreement, but only with respect to the operations of the named insured, and subject to the provisions and limitations of form ECG20 600 - Additional Insured - Blanket when required by written contract, but only with respect to the USAT sanctioned or approved event specified on this certificate.

The General Liability policy is primary as per Form ECG24 520 (04/02) and the General Liability policy contains Form ECG24 522 (04/02): Waiver of Transfer of Rights of Recovery Against others to US, but only as required by written contract or agreement executed by the named insured prior to an occurrence resulting See Attached...

CERTIFICATE HOLDER**CANCELLATION**

Town of Clifton Park One Town Hall Plaza Clifton Park NY 12065	SHOULD ANY OF THE ABOVE DESCRIBED POLICIES BE CANCELLED BEFORE THE EXPIRATION DATE THEREOF, NOTICE WILL BE DELIVERED IN ACCORDANCE WITH THE POLICY PROVISIONS. AUTHORIZED REPRESENTATIVE
--	---

© 1988-2015 ACORD CORPORATION. All rights reserved.

THIS ENDORSEMENT CHANGES THE COVERAGE PART. PLEASE READ IT CAREFULLY.

ADDITIONAL INSURED – AUTOMATIC STATUS WHEN REQUIRED IN A WRITTEN AGREEMENT WITH YOU

This endorsement modifies insurance provided under the following:

COMMERCIAL GENERAL LIABILITY COVERAGE PART

- A. Section II – Who Is An Insured** is amended to include as an additional insured any person or organization with whom you have a written agreement that such person or organization be added as an additional insured on your Coverage Part. Such person or organization is an additional insured only with respect to liability for "bodily injury", "property damage" or "personal and advertising injury" but only to the extent caused, in whole or in part, by:
1. Your acts or omissions; or
 2. The acts or omissions of those acting on your behalf;
- in the performance of your operations for an additional insured.
- B.** The insurance afforded to an additional insured shall only include the insurance required by the terms of the written agreement and shall not be broader than the coverage provided within the terms of the Coverage Part.
- C.** The Limits of Insurance afforded to an additional insured shall be the lesser of the following:
1. The Limits of Insurance required by the written agreement between the parties; or
 2. The Limits of Insurance provided by this Coverage Part.
- D.** With respect to the insurance afforded to an additional insured, this insurance does not apply to "bodily injury", "property damage" or "personal and advertising injury" arising out of any act or omission of an additional insured or any of its employees.

THIS ENDORSEMENT CHANGES THE POLICY. PLEASE READ IT CAREFULLY.

AMENDMENT – OTHER INSURANCE (PRIMARY NONCONTRIBUTORY)

This endorsement modifies insurance provided under the following:

COMMERCIAL GENERAL LIABILITY COVERAGE PART

A. Paragraph a. Primary Insurance of 4. Other Insurance of SECTION IV COMMERCIAL GENERAL LIABILITY CONDITIONS is replaced by the following:

a. Primary Insurance

This insurance is primary except when b. below applies. If this insurance is primary, our obligations are not affected unless any of the other insurance is also primary. Then, we will share with all that other insurance by the method described in c. below, except that we will not seek contribution from any party with whom you have agreed in a written contract or agreement that this insurance will be primary and noncontributory, if the written contract or agreement was made prior to the subject "occurrence" or offense.

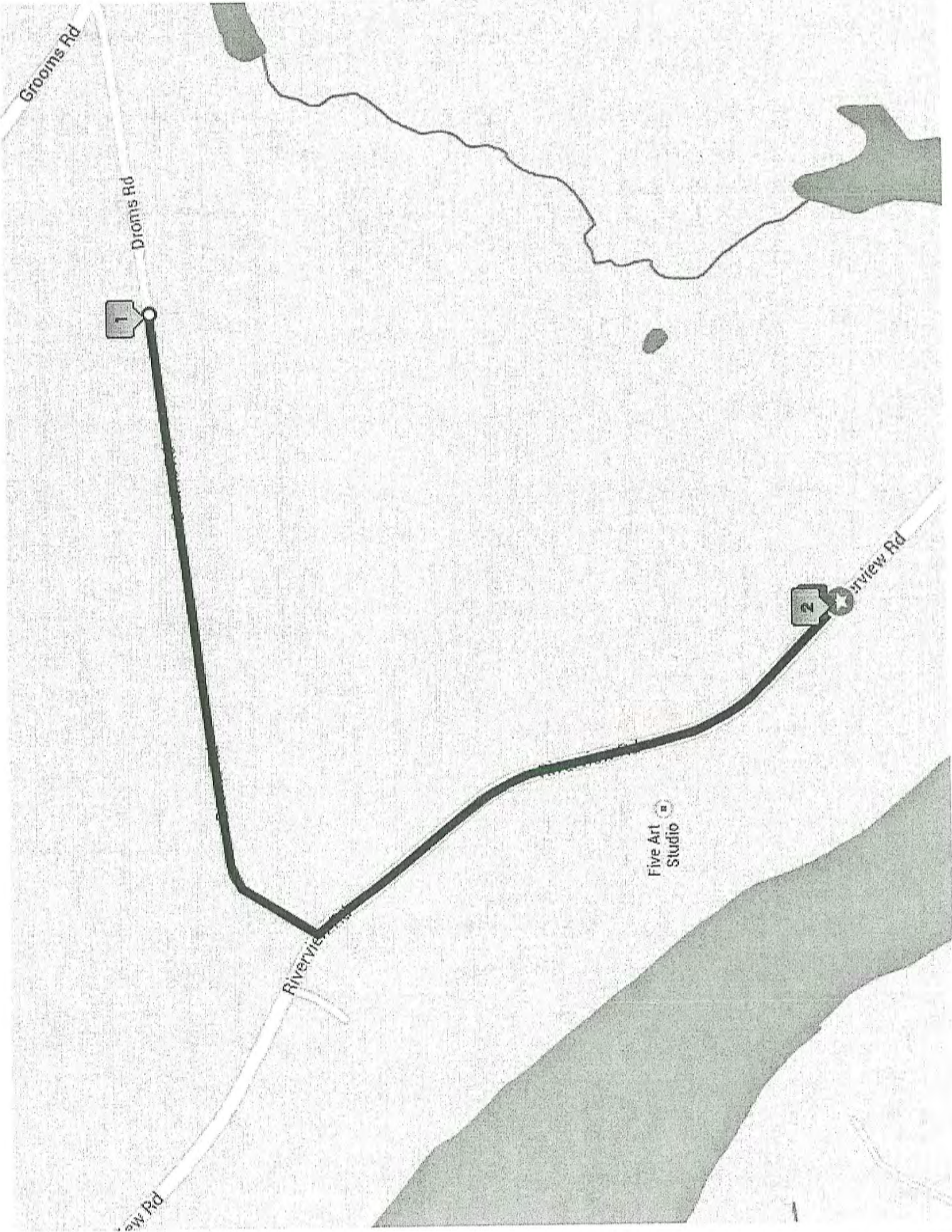

Grooms Rd

Droms Rd

1

2

Riverview Rd

Five Art Studio

Riverview Rd

New Rd

RESOLUTION
#5

Resolution No. _____ of 2022, a resolution approving the appointment of Everett Noakes to the Industrial Development Agency.

Introduced by _____, who moved its adoption, seconded by _____.

WHEREAS, a vacancy exists for a 7th member to the Industrial Development Agency, and

WHEREAS, Supervisor Barrett recommends Everett Noakes, a Clifton Park resident, to fill the position, and

WHEREAS, this appointment will confer a benefit to the Town of Clifton Park; now, therefore, be it

RESOLVED, that Everett Noakes is hereby appointed as a member for the remainder of a 3-year term, term to expire December 31, 2024.