

TOWN OF CLIFTON PARK TOWN BOARD MEETING

February 24, 2026

The Town Board meeting can be viewed live by visiting www.cliftonpark.org Scroll down to click

 **ONLINE BOARD MEETINGS**

- I. Call to Order/7:00 P. M. – Wood Room, Town Hall**
- II. Pledge to Flag**
- III. Roll Call**
- IV. Approval of Town Board Minutes**
- V. Communications/Announcements**
- VI. Open Public Privilege**
- VII. Business**
 - **Presentation by CAPTAIN Executive Director Scott DiMarco**
 - **Public Hearing- 7:02pm: Related to amendments to Town Code Ch. 17-13, Ethics Board**
 - **Resolutions for Consideration**
 - **Other Business**
- VIII. Open Public Privilege**

NOTE:

Please check www.cliftonparkny.gov for final agenda and updates. Each speaker shall state name and address prior to addressing the Board and shall be granted the floor for a single time frame of up to three minutes. The Board asks that members of the public respect the opportunity of the speaker at the podium to be heard, and asks that the public refrain from conducting side meetings within the meeting room. In an effort to ensure that the widest number of community viewpoints are heard, the Board asks members of groups or the public to withhold comment, if their viewpoints have already been presented. The Board thanks everyone in attendance for their understanding and also for their desire to actively participate in the Town decision making process.

- IX. Adjournment**

TOWN OF CLIFTON PARK
COUNTY OF SARATOGA
STATE OF NEW YORK

NOTICE OF PUBLIC HEARING TO CONSIDER A LOCAL LAW AMENDING TOWN CODE
CHAPTER 17- CODE OF ETHICS

Please take notice that the Town Board of the Town of Clifton Park will conduct a public hearing on Tuesday, February 24, 2026, at 7:02 PM in the Wood Memorial Meeting Room in the Town Office Building, located at One Town Hall Plaza, Town of Clifton Park, County of Saratoga, State of New York, whereas, the Town Board wishes to address and amend Town Code Chapter 17, Code of Ethics.

Copies of the proposed local law are posted on our website cliftonparkny.gov and is also available for review in the Town Clerk's office during normal business hours.

Caitlin Fantini,
Clifton Park Town Clerk

Proposed changes to Chapter 17 Ethics Code

§17-13 Ethics Board

C.

The [Ethics Board] Town Board shall select [its own] the Ethics Board Chairman for a one-year term.

E.

The Ethics Board members shall be appointed by [unanimous consent of] majority vote of the Town Board.

[G.]

[In the event the Town Board is unable to fill the vacancies as set forth hereinabove, then, in such case, the County Board of Ethics shall select the individuals to fill any vacancies.]

And paragraphs H. I. and J. are to be re-lettered paragraphs G. H. and I.

Resolutions for Consideration
Clifton Park Town Board Meeting
February 24, 2026

<u>SOURCE</u>	<u>RESOLUTION</u>	<u>CONTACT</u>
1. Town Board	Adopt Local Law No. __ of 2026, related to amendments to Town Code Ch. 17-13, Ethics Board	Z. Manir
2. Town Board	Authorize support of the America 250 Commemoration and authorize related expenditures	N. Bellamy
3. Town Board	Authorize reappointments to the Clifton Park Water Authority related to filings of Oaths of Office	M. Fantini
4. Town Board	Authorize reappointments to the Clifton Park Water Authority	P. Barrett
5. Town Board	Authorize the Supervisor to sign a contract with the Saratoga County Sheriff's Department for specialized law enforcement services.	P. Barrett
6. Town Board	Authorize compensatory time or adjustment to leave-with -pay time to Town employees affected by the Town Hall snow day closure on January 26, 2026	M. Fantini
7. Town Board	Authorize establishment of a Hiring Coordination and Procedure process for the Town Board	M. Fantini
8. Town Board	Authorize reduction in the public electric vehicle (EV) charging fee at Town EV chargers	M. Fantini
9. Town Board	Authorize Town Attorney to settle three (3) Town lawsuits related to Highway paving	Town Attorney
10. Senior Center	Authorize waiving of Senior Center Facility Rental Fee for Blood Cancer United's fundraiser on 2/28/2026	P. Barrett
11. Buildings & Grounds	Authorize purchase of an enclosed equipment trailer and a tilt trailer from Griffin Motorsports	P. Barrett

12. Buildings & Grounds	Authorize purchase of Mohawk TR-19, 4-post lift for the department shop	P. Barrett
13. Buildings & Grounds	Authorize acceptance of the bid from County Waste & Recycling Service, Inc. for dumpster service for various Town locations	P. Barrett
14. Buildings & Grounds	Authorize acceptance of the bid from Casella Waste Management of NY, Inc. for Transfer Station Solid Waste Disposal	P. Barrett
15. Sewer	Authorize purchase of a 2026 Ford F-350 Regular Cab Truck under NYS Vehicle mini-bid system	P. Barrett
16. Sewer	Authorize purchase of a new grinder pump service truck	P. Barrett
17. Assessor	Authorize correction to Resolution No. 73 of 2022, related to the term for a member of the Board of Assessment Review	M. Fantini
18. Highway	Authorize hiring of a Motor Equipment Operator (MEO)	D. Bull
19. Highway	Authorize a one (1) year extension of the department's contract with DLC Electric	D. Bull



RESOLUTION

#1

PHILIP C. BARRETT
Supervisor

AGATHA REID
Councilwoman

ZABED MANIR
Councilman

NANCY R. BELLAMY
Councilwoman

MARIO L. FANTINI
Councilman

Resolution No. ___ of 2026, a resolution adopting a local law to amend Town Code Chapter 17, Code of Ethics.

Introduced by _____, who moved its adoption, seconded by _____.

WHEREAS, if the Town Board of the Town of Clifton Park cannot agree on new members by unanimous consent, local law requires new members to be appointed by the County Ethics Board, as set forth in Chapter 17, Ethics code, §17-13 as last amended by Local Law No. 4 of 1994, and

WHEREAS, the County Ethics Board lacks the authority and should have no authority to appoint members of a Town's Ethics Board, and

WHEREAS, it is appropriate that the power to appoint members and the chairperson of the Town's Ethics Board be appointed by a majority vote of the Town Board, and

WHEREAS, on February 24, 2026, the Town Board held a public hearing on a proposal to consider these amendments to Town Code Chapter 17, Code of Ethics, §17-13; now, therefore, be it

RESOLVED, that Local Law No. ___ of 2026, a local law to allow appointment of Ethics Board members by a majority vote of the Town Board, as detailed in the attached; and be it further

RESOLVED, that this local law shall take effect immediately upon its adoption.

Proposed changes to Chapter 17 Ethics Code

§17-13 Ethics Board

C.

The [Ethics Board] Town Board shall select [its own] the Ethics Board Chairman for a one-year term.

E.

The Ethics Board members shall be appointed by [unanimous consent of] majority vote of the Town Board.

[G.]

[In the event the Town Board is unable to fill the vacancies as set forth hereinabove, then, in such case, the County Board of Ethics shall select the individuals to fill any vacancies.]

And paragraphs H. I. and J. are to be re-lettered paragraphs G. H. and I.



RESOLUTION

#2

PHILIP C. BARRETT
Supervisor

AGATHA REID
Councilwoman

ZABED MANIR
Councilman

NANCY R. BELLAMY
Councilwoman

MARIO L. FANTINI
Councilman

RESOLUTION NO. ___ OF 2026, A RESOLUTION OF THE TOWN OF CLIFTON PARK IN SUPPORT OF THE AMERICA 250 COMMEMORATION AND AUTHORIZING RELATED EXPENDITURES.

Introduced by _____, who moved its adoption, seconded by _____.

WHEREAS, the United States of America will commemorate its 250th anniversary on July 4, 2026, marking a historic milestone in our nation's history; and

WHEREAS, on July 4, 1776, the Second Continental Congress formally adopted the Declaration of Independence, asserting the American colonies' freedom from British rule and laying the foundation for the principles of democracy and self-governance; and

WHEREAS, the U.S. Semiquincentennial Commission, known as the America 250 Commission (america250.org), was established by Congress in 2016 to plan and coordinate the national commemoration of the 250th anniversary of the signing of the Declaration of Independence; and

WHEREAS, the New York State 250th Commemoration Commission was created to lead statewide efforts to commemorate the founding of the United States and New York's pivotal role in the nation's formation and development; and

WHEREAS, Town Law authorizes the town board to appropriate funds for the proper observance of patriotic and historical events (Town Law § 64 [12], [14]), and Arts and Cultural Affairs Law § 57.07 further authorizes local governments to appropriate and expend funds for historical purposes within their jurisdiction, including the erection of markers and monuments, the preservation of historical materials, and cooperation with local historical organizations; and

WHEREAS, these statutes provide the legal authority for towns to engage in and support commemorations that are educational, patriotic, and historical in character, including public programming, exhibits, community events, and historical preservation activities connected to America 250; and

WHEREAS, the Town of Clifton Park recognizes the importance of America 250 as an opportunity to reflect on our community's contributions to the American story, honor the achievements of past generations, and inspire renewed civic engagement.

NOW THEREFORE BE IT RESOLVED, that the Town Board of the Town of hereby expresses its support for the America 250 Commemoration and authorizes the town board and appropriate departments to plan, promote, and participate in programs and events consistent with the purposes of Town Law § 64 and Arts and Cultural Affairs Law 57.07; and

BE IT FURTHER RESOLVED, that such activities may include, but are not limited to, educational programming, historical exhibits, patriotic decorations, community celebrations, and collaborations with local schools, libraries, and historical societies, provided that all expenditures serve a proper public purpose and comply with applicable fiscal and procurement requirements.



RESOLUTION

#3

PHILIP C. BARRETT
Supervisor

AGATHA REID
Councilwoman

ZABED MANIR
Councilman

NANCY R. BELLAMY
Councilwoman

MARIO L. FANTINI
Councilman

Resolution No. _____ of 2026, a resolution authorizing reappointment of members to the Clifton Park Water Authority (CPWA) Board of Directors.

Introduced by _____, who moved its adoption, seconded by _____.

WHEREAS, that as a result of a failure to timely file an Oath of Office as is required by the Public Officers Law, that CPWA Board members Helmet Gerstenberger, who was appointed on January 6, 2025, and John Ryan, who was appointed on January 2, 2024, resulted by law in these positions being open and vacant, and

WHEREAS, the Town Board desires to fill these positions and to reappoint Helmet Gerstenberger and John Ryan to the CPWA; now, therefore, be it

RESOLVED, that Helmet Gerstenberger and John Ryan are reappointed to the Clifton Park Water Authority as of even date herewith, to serve the remainder of their respective terms, to wit: December 31, 2029, and December 31, 2028.



RESOLUTION

#4

PHILIP C. BARRETT
Supervisor

AGATHA REID
Councilwoman

ZABED MANIR
Councilman

NANCY R. BELLAMY
Councilwoman

MARIO L. FANTINI
Councilman

Resolution No. _____ of 2026, a resolution authorizing reappointment of members to the Clifton Park Water Authority (CPWA) Board of Directors.

Introduced by _____, who moved its adoption, seconded by _____.

WHEREAS, the Supervisor reappoints Helmet Gerstenberger to serve as Chairman of the CPWA, and

WHEREAS, Peter Taubkin and Kenneth Bowman are reappointed to serve as members of the CPWA, and

WHEREAS, the presence of Mr. Gerstenberger, Mr. Taubkin and Mr. Bowman on the CPWA will confer a benefit to the Town of Clifton Park; now, therefore be it

RESOLVED, that Helmet Gerstenberger, of Clifton Park, NY, is hereby reappointed as the Chairman of the Clifton Park Water Authority (CPWA) Board of Directors for a term to expire 12/31/2026, and Peter Taubkin, Clifton Park, NY and Kenneth Bowman, Rexford, NY, are hereby reappointed to the CPWA Board of Directors for five-year terms, terms to expire December 31, 2030.



RESOLUTION

#5

PHILIP C. BARRETT
Supervisor

•

AGATHA REID
Councilwoman

ZABED MANIR
Councilman

•

NANCY R. BELLAMY
Councilwoman

•

MARIO L. FANTINI
Councilman

Resolution No. _____ of 2026, a resolution authorizing the Town Supervisor to sign an agreement with the Saratoga County Sheriff's Department for Specialized Law Enforcement Services, and to transfer funds from Contingency.

Introduced by _____, who moved its adoption, seconded by _____ .

WHEREAS, the Town of Clifton Park has found it to be effective and efficient to obtain law enforcement services within the Town through the Saratoga County Sheriff's Department, and

WHEREAS, the Town Board wishes to renew the existing Agreement for Specialized Law Enforcement Services with the Saratoga County Sheriff's Department, per the attached agreement; now, therefore, be it

RESOLVED, that the Supervisor is authorized to sign the attached agreement with the Saratoga County Sheriff's Department whereby the Sheriff's Department shall provide Specialized Law Enforcement Services within the Town of Clifton Park for a one (1) year period from January 1, 2026 through December 31, 2026, for an amount not to exceed \$748,095.82, to be paid in monthly payments of \$62,341.32 from A-3120-15 (General Fund-Security-Other Contractual); and be it further

RESOLVED, that the Town Comptroller transfer from Contingency, A-01990-00015, \$10,800 to A- 03120-00015, (General Fund – Law Enforcement – Other Contractual), to cover the cost of the contract.

Cynthia Zlogar

From: Town of Clifton Park Official Website <info@cliftonpark.org>
Sent: Friday, February 6, 2026 2:31 PM
To: Cynthia Zlogar
Subject: Confirmation: New Resolution Request #2570

Your resolution request has been sent. The details of your submission are included with this confirmation email.

Department: Legal

Your Name: Cindy Zlogar

Your Email: czlogar@cliftonpark.org

Sponsor: K. Dailey

Agenda Session Date: 02/24/2026 ✓

Board Meeting Date: 02/24/2026 ✓

Alternate Date: 02/24/2026

Budget Number: A-3120-15

Budget Description: General Fund-Security-Other Contractual

Amount: \$748,095.82

Brief Description: Authorize Supervisor to execute the annual County agreement for Specialized Law Enforcement Services

Add Supporting Docs:

[fe6194d9c2906de2_2026_Specialized_Law_Services_Agreement_with_County.pdf](#)

Additional Comments/Details: N/A

Agree to Terms: Agree

[unsubscribe](#)



**OFFICE OF THE
COUNTY ATTORNEY**

GEORGE P. CONWAY, ESQ., COUNTY ATTORNEY

518.884.4770

SARATOGACOUNTY.NY.GOV

40 MC MASTER ST, BALLSTON SPA, NY 12020

First Assistant Attorney
Ann Flower E. Stitt, Esq.
Assistant Attorneys
Michael E. DiPresso, Esq.
Petra A. Holden, Esq.
Karen M. "Kate" Kelly, Esq.

SERVICE BY EMAIL NOT ACCEPTED

MEMORANDUM

DATE: January 29, 2026
TO: Jeffrey R. Brown,
Sheriff
FROM: George P. Conway *GPC*
County Attorney
SUBJECT: Town of Clifton Park - Law Enforcement Services 2026

- For Vendor Signature & Return
- Per Resolution No. 333 - 2025
- For Your Approval
- Per Our Conversation
- For Your Information
- For Your Files
- For Your Review
- For Appropriate Action
- Comments/Recommendations
- Other: _____

MESSAGE/REMARKS: Attached, please find one (1) partially executed agreement with the above-named vendor. **If this agreement meets your approval, please secure the signature of the contractor/vendor and return one (1) signed document to this office for further processing.**

AGREEMENT FOR SPECIALIZED LAW ENFORCEMENT SERVICES

THIS AGREEMENT, BY AND BETWEEN,

COUNTY OF SARATOGA, a municipal corporation duly organized under the laws of the State of New York with a principal office at 40 McMaster Street, Ballston Spa, New York 12020 (COUNTY), acting through its Sheriff's Office (SHERIFF),

-and-

TOWN OF CLIFTON PARK, a municipal corporation duly organized under the laws of the State of New York with a principal office at 1 Town Hall Plaza, Clifton Park, New York 12065 (TOWN)

1. STATEMENT OF AGREEMENT

The COUNTY and SHERIFF will provide "Specialized Protection" to the TOWN during the term of this Agreement. The TOWN agrees to pay for such services as outlined herein. Both parties wish to continue this mutually beneficial relationship.

2. LEGAL BASIS

This Agreement is authorized by 119-o of the General Municipal Law.

3. SPECIALIZED PROTECTION

Specialized Protection is that protection provided to the TOWN in excess of that normally furnished by the SHERIFF. In this case, Specialized Protection is defined as a higher quality and level of exclusive service not normally provided by regular COUNTY patrol. All references to Specialized Protection or specialized law enforcement services are those services to be delivered hereunder.

4. DELIVERY OF SERVICE

4.1 Service Area: The SHERIFF shall provide Specialized Protection within the corporate limits of the TOWN. Assigned Deputies will not leave the TOWN except in an extreme emergency and will continue the expanded presence and patrol for designated parklands and residential and secondary roadways within the TOWN.

4.2 Enforcement Responsibilities: The SHERIFF shall enforce State statutes, COUNTY ordinances, and those TOWN ordinances that are of the same type and nature as COUNTY ordinances enforced by the SHERIFF. The SHERIFF shall not be required to assume any other enforcement duty or function not consistent with those customarily performed by the SHERIFF under the laws of the State.

- 4.3 Services to be Delivered: The SHERIFF shall provide two patrols Monday through Sunday, from 8:00 a.m. to 4:00 p.m. and from 4:00 p.m. to 12:00 a.m., to patrol the TOWN at the cost of \$748,095.82, to be paid in equal monthly installments. In addition, the SHERIFF shall provide additional police services to the TOWN for added patrols or special detail assignments as shall be determined by the SHERIFF, the cost of which services shall be included within the total contract cost of \$748,095.82. The SHERIFF reserves the right to modify the foregoing schedule based on the changing needs of law enforcement in the TOWN.
- 4.4 Reporting: The SHERIFF shall provide to the TOWN a monthly report of all law enforcement services provided by the SHERIFF within the TOWN each month.
- 4.5 Service Management: The SHERIFF shall determine the planning, organization, scheduling direction, and supervision of its personnel and all other matters incident to the delivery of specialized law enforcement services to the TOWN. The SHERIFF shall retain exclusive authority over its personnel.
- 4.6 Responsiveness: The SHERIFF shall promptly consider all TOWN requests regarding the delivery of specialized law enforcement services and make every effort to comply with them in a manner consistent with good law enforcement practices and this Agreement.
- 4.7 Dispute Resolution: Any conflict regarding the extent or manner of performance of the specialized law enforcement services shall be resolved by the SHERIFF and the TOWN Supervisor. The SHERIFF's decision shall be final and conclusive.
- 4.8 Coordination: The TOWN and SHERIFF shall each designate a specific individual and alternates to coordinate and implement the delivery of specialized law enforcement services to the TOWN.

5. RESOURCES

- 5.1 COUNTY Responsibilities: Except as otherwise agreed, the COUNTY and SHERIFF shall furnish all labor, equipment, facilities, and supplies.
- 5.2 TOWN Responsibilities: The TOWN shall provide and maintain heat, lights, and phones at the facilities.

6. LIABILITY

The COUNTY shall assume liability for and secure the TOWN from claims and/or all costs for damages allegedly caused by the SHERIFF's personnel and arising out of the performance of this Agreement.

7. **PERSONNEL**

7.1 **Employee Status:** For purposes of this Agreement only, all persons employed by the SHERIFF for this Specialized Protection shall be COUNTY officers or employees, and they shall not have any benefit, status, or right of TOWN employment.

7.2 **Payment:** The TOWN shall not be liable for the direct payment of salaries, wages, workers compensation benefits, or any other compensation for COUNTY officers or employees providing specialized law enforcement services hereunder.

8. **DURATION**

The term of this Agreement shall be for one year, from January 1, 2026 through December 31, 2026.

9. **TERMINATION**

This Agreement may be terminated at any time upon ninety days (90) prior written notice to the other party.

10. **AUTHORIZATION**

This Agreement is made and executed pursuant to COUNTY Resolution 333-2025 and a resolution approved by the Town Board of Clifton Park on _____.

11. **EXECUTION**

The parties have hereunto signed this Agreement on the day and year appearing under their respective signatures.

--- SIGNATURE PAGE TO FOLLOW ---

COUNTY OF SARATOGA

TOWN OF CLIFTON PARK

By: _____
Ian Murray, Vice-Chair
Saratoga County Board of Supervisors
Pursuant to Resolution: 333-2025

By: _____
Philip C. Barrett
Town Supervisor
Pursuant to Resolution: _____-2026

Date: _____

Date: _____

By: _____
Jeffrey R. Brown
Saratoga County Sheriff

Date: _____

Approved as to form and content:

Approved as to form and content:

By: _____
George P. Conway
County Attorney

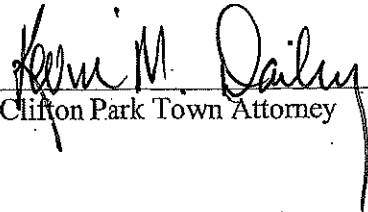
By:  _____
Clifton Park Town Attorney



BOARD OF SUPERVISORS

11/18/2025

RESOLUTION 333 – 2025

Introduced by Public Safety: Supervisors Lant, Ball, Butler, Fish, Ostrander, Wright, and Young

AUTHORIZING AN AGREEMENT WITH THE TOWN OF CLIFTON PARK FOR LAW ENFORCEMENT SERVICES IN 2026

WHEREAS, pursuant to Resolution 281 – 2024, this Board authorized an agreement with the Town of Clifton Park for the provision of law enforcement services by the Saratoga County Sheriff's Office for a term of one (1) year, commencing January 1, 2025 and expiring December 31, 2025; and

WHEREAS, the Town of Clifton Park wishes to enter into a new agreement for the provision of law enforcement services by the Sheriff's Office in 2026; and

WHEREAS, the proposed agreement, commencing January 1, 2026 and expiring December 31, 2026, includes reimbursement by the Town of Clifton Park for all County-incurred expenses, including salaries, benefits, training, patrol cars, and all associated transportation expenses; and

WHEREAS, our Public Safety Committee and the Sheriff have recommended that the County enter into an agreement with the Town of Clifton Park for the provision of law enforcement services for a term of one (1) year, commencing January 1, 2026 and expiring December 31, 2026; now, therefore, be it

RESOLVED, that the Chair of the Board of Supervisors is hereby authorized to execute an agreement with the Town of Clifton Park, in an amount of \$748,095.82, for the provision of law enforcement services for a term of one (1) year, commencing January 1, 2026 and expiring December 31, 2026, pursuant to the following:

Number of Patrols	Service Time of Patrols	Service Area	Amount
2	8:00am – 4:00pm, Monday – Sunday	The Entire Town of Clifton Park	\$ 748,095.82
2	4:00pm – 12:00am, Monday – Sunday		

; and be it further

RESOLVED, that the Sheriff's Office shall provide such law enforcement services to the Town of Clifton Park for added patrols and/or special detail assignments as determined by the Sheriff, the cost of which services shall be included within the stated amount of the agreement; and be it further

RESOLVED, that the Sheriff shall have the right to modify the foregoing schedule based upon the changing needs of law enforcement within the Town of Clifton Park; and be it further

RESOLVED, that the form and content of such agreement shall be subject to the approval of the County Attorney; and be it further

RESOLVED, that this Resolution shall take effect immediately.

BUDGET IMPACT STATEMENT: No budget impact. Funds are included in the department budget.

November 18, 2025 Regular Meeting

Motion to Adopt: Supervisor M. Veitch

Second: Supervisor Murray

AYES (144,959): Eric Connolly (11831), Joseph Grasso (4328), Philip C. Barrett (19014.5), C. Eric Butler (6500), Harry Brennan (819), Robert Anderson (1333), James D. Arnold (3525), Kevin Veitch (8004), Cynthia Young (17130), Thomas Richardson (5163), Scott Ostrander (18800), Sandra Winney (2075), Ian Murray (5808), Matthew E. Veitch (14245.5), Edward D. Kinowski (9022), John Lant (17361)

NOES (0):

ABSENT (90,550): Angela Thompson (19014.5), Arthur M. Wright (1976), Kevin Tollisen (25662), Jesse Fish (16202), Willard H. Peck (5242), Michele Madigan (14245.5), David Ball (8208)



RESOLUTION

#6

PHILIP C. BARRETT
Supervisor

AGATHA REID
Councilwoman

ZABED MANIR
Councilman

NANCY R. BELLAMY
Councilwoman

MARIO L. FANTINI
Councilman

Resolution No. _____ of 2026, a resolution to provide compensatory time or a refund of leave-with-pay time to Town employees affected by the inconsistent communication regarding a snow day closure.

Introduced by _____, who moved its adoption, seconded by _____.

WHEREAS, a text message was sent to department heads on Sunday, January 25, 2026 at approximately 2:20pm indicating that the Town Hall would be closed on Monday, January 26, 2026 due to inclement weather and instructed Town employees to stay home, and

WHEREAS, this decision was reversed at approximately 8:00am on Monday, January 26, 2026 and employees were directed to report to work at 10:00am, and

WHEREAS, many employees had already made plans regarding childcare and having their driveways plowed later in the day, and could not make it into work, and

WHEREAS, this has negatively impacted staff morale and created confusion due to inconsistent messaging, and

WHEREAS, to address the effects of this inconsistency and to maintain employee confidence in organizational communications, it is appropriate to provide consistency for those initially instructed to stay home who came to work and those who could not come to work; now, therefore, be it

RESOLVED, that for all Town employees who did not come to work on January 26, 2026, and used leave-with-pay time, the Comptroller's office will return this time, starting at 10:00am, to their leave bank; and be it further

RESOLVED, that all non-essential employees who came to work on January 26, 2026, be granted compensatory time equivalent to the time they worked; and be it further

RESOLVED, that the Town notify affected employees accordingly.

Cynthia Zlogar

From: Town of Clifton Park Official Website <info@cliftonpark.org>
Sent: Thursday, February 12, 2026 6:24 PM
To: Cynthia Zlogar; Phil Barrett; Jean Spiegel; Mark Heggen; Darlene Allen; Zabed Manir; Agatha Reid; John Scavo; Christine Pagnello; Walter Smead; Kelly Miller; Nancy Bellamy; Mario Fantini; Kevin Dailey; Caitlin Fantini
Subject: New Resolution Request #2605

A new resolution request has been submitted. The details of this resolution request are included below.

Department: Town Board

Your Name: Mario Fantini

Your Email: mfantini@cliftonpark.org

Sponsor: Mario Fantini

Agenda Session Date: 02/24/2026 ✓

Board Meeting Date: 02/24/2026 ✓

Alternate Date: 02/24/2026

Budget Number: NA

Budget Description: NA

Amount: NA

Brief Description: This resolution addresses the inconsistent messaging regarding the Town Hall closure on Monday, January 26, 2026.

A text sent Sunday, January 25 at ~2 p.m. told employees to stay home due to weather. The order was reversed at ~8:00 a.m. Monday, requiring staff to report at 10:00 a.m. Many employees had already made child-care and snow-removal plans and could not come in.

To restore fairness and morale, the resolution provides:

- Employees who stayed home will have their paid time off refunded.
- Employees who reported to work will receive compensatory time equal to the hours worked.

This only applies to employees who were initially instructed to stay home.

Add Supporting Docs:

Additional Comments/Details: NA

Agree to Terms: Agree

[unsubscribe](#)



RESOLUTION

#7

PHILIP C. BARRETT
Supervisor

AGATHA REID
Councilwoman

ZABED MANIR
Councilman

NANCY R. BELLAMY
Councilwoman

MARIO L. FANTINI
Councilman

Resolution No. of 2026, a resolution establishing a Hiring Coordination and Procedure process for the Town Board.

Introduced by _____, who moved its adoption, seconded by _____.

WHEREAS, the Town Board recognizes the importance of a consistent, transparent, and organized process for receiving employment applications, reviewing candidate materials, coordinating interviews, and ensuring that all Town Board members are informed and given the opportunity to participate in hiring discussions, and

WHEREAS, the Town Board desires to establish a uniform internal workflow for handling employment candidates in a manner that promotes preparedness, fairness, and clear communication, and

WHEREAS, past practice has at times resulted in uncertainty regarding how applications are received, how candidate materials are distributed, and how interviews are scheduled and communicated among Town Board members; now therefore be it

RESOLVED, that the Town Board hereby adopts the Town of Clifton Park Hiring Coordination and Procedure process, as set forth in Attachment A, as the standard internal workflow for positions appointed by, reporting to, or otherwise requiring involvement of the Town Board; and be it further

RESOLVED, that all employment applications, resumes, and candidate materials for such positions shall be centrally received, logged, and organized to ensure proper tracking and consistency; and be it further

RESOLVED, that candidate names, resumes, and related materials shall be circulated to all Town Board members in advance of interviews or consideration, to allow adequate review and preparation; and be it further

RESOLVED, that when interviews are to be conducted for such positions, scheduling logistics and candidate communications shall be coordinated centrally to avoid confusion or duplication, and all Town Board members shall be notified and given the opportunity to participate; and be it further

RESOLVED, that to ensure continuity and organization of this process, the logistical coordination of application receipt, material distribution, interview scheduling, and candidate communications shall be the responsibility of the Confidential Administrative Assistant to the Town Board, a role that is administrative and coordinative in nature and does not alter the duties and responsibilities of the Town Supervisor or the appointing authority of the Town Board or any department head.

ATTACHMENT A

Town of Clifton Park Hiring Coordination and Procedure

1. **Purpose:** The Town Board recognizes the importance of a consistent, transparent, and organized process for receiving employment applications, reviewing candidate materials, coordinating interviews, and ensuring that all Town Board members are informed and given the opportunity to participate in hiring discussions. This procedure is intended to establish a uniform internal workflow for handling employment candidates that promotes preparedness, fairness, and clear communication.
2. **Receipt of Applications:** All employment applications, resumes, and candidate materials submitted to the Town for positions appointed by or reporting to the Town Board shall be centrally received and logged to ensure proper tracking and organization.
3. **Distribution of Candidate Materials:** Candidate names, resumes, and related application materials shall be circulated to all Town Board members in advance of interviews or consideration to allow adequate review and preparation.
4. **Interview Coordination:** When interviews are to be conducted for positions under Town Board purview:
 - Scheduling logistics shall be coordinated centrally to avoid confusion and duplication.
 - All Town Board members shall be notified of interview dates and times and given the opportunity to participate.
 - Candidate communications regarding scheduling shall be handled in a consistent and professional manner.

Role of the Confidential Administrative Assistant to the Town Board

- To ensure continuity and organization of this process, the logistical coordination of application receipt, material distribution, interview scheduling, and candidate communications shall be facilitated through the Confidential Administrative Assistant to the Town Board.
- This role is administrative and coordinative in nature and does not alter the appointing authority of the Town Board or any department head.
- This procedure is adopted to promote clarity, preparedness, inclusivity, and orderly administration of the Town's hiring workflow and to avoid confusion regarding how employment candidates are received, reviewed, and scheduled for consideration.



RESOLUTION

#8

PHILIP C. BARRETT
Supervisor

AGATHA REID
Councilwoman

ZABED MANIR
Councilman

NANCY R. BELLAMY
Councilwoman

MARIO L. FANTINI
Councilman

Resolution No. __ of 2026, a resolution to amend the Electric Vehicle (EV) charging fee at Town EV chargers to an at-cost rate.

Introduced by _____, who moved its adoption, seconded by _____.

WHEREAS, the Town of Clifton Park has established electric vehicle charging stations operated through SWITCH, with a current charging fee of \$0.30 per kilowatt-hour, and

WHEREAS, this fee includes the Town's utility rate of approximately \$0.15 per kilowatt during peak periods, a 10% transaction fee applied by SWITCH to each charging session, and an additional \$0.15 per kilowatt to recover annual network and management service fees of \$240 per charger for the Town's twelve chargers, and

WHEREAS, New York State's Climate Leadership and Community Protection Act (CLCPA) establishes binding targets to reduce statewide greenhouse gas emissions 40 percent below 1990 levels by 2030 and 85 percent by 2050, and encourages local governments to support the transition to cleaner transportation alternatives to help achieve these goals, and

WHEREAS, many municipalities in the Capital Region, including Saratoga Springs, Voorheesville, Niskayuna, Albany, and Glen Falls, currently provide free public EV charging at government-owned facilities, and

WHEREAS, to promote the adoption of electric vehicles and sustainable transportation, it is desirable to set the charging fee at the Town's direct variable costs for electricity and transaction fees, without including recovery of fixed annual service fees; now, therefore, be it

RESOLVED, that the Town of Clifton Park's electric vehicle charging fee be amended to \$0.165 per kilowatt-hour; and be it further

RESOLVED, that these charging fees will be reviewed yearly and are subject to change based on utility costs, service fees, and the need to purchase or repair equipment; and be it further

RESOLVED, that the Director of Planning & Zoning is authorized to make the above-stated amendment and implement the revised fee.

Cynthia Zlogar

From: Town of Clifton Park Official Website <info@cliftonpark.org>
Sent: Thursday, February 12, 2026 6:51 PM
To: Cynthia Zlogar; Phil Barrett; Jean Spiegel; Mark Heggen; Darlene Allen; Zabed Manir; Agatha Reid; John Scavo; Christine Pagnello; Walter Smead; Kelly Miller; Nancy Bellamy; Mario Fantini; Kevin Dailey; Caitlin Fantini
Subject: New Resolution Request #2607

A new resolution request has been submitted. The details of this resolution request are included below.

Department: Town Board
Your Name: Mario Fantini
Your Email: mfantini@cliftonpark.org
Sponsor: Mario Fantini
Agenda Session Date: 02/24/2026 ✓
Board Meeting Date: 02/24/2026 ✓
Alternate Date: 02/24/2026
Budget Number: NA
Budget Description: NA
Amount: NA

Brief Description: This resolution lowers the public electric vehicle charging fee from \$0.30 per kWh to \$0.165 per kWh.
The new rate covers only the Town's direct electricity cost (≈ \$0.15/kWh) plus SWTCH's 10% transaction fee, removing the previous markup used to recover fixed annual network and management fees.

The change aligns with New York State's Climate Leadership and Community Protection Act (CLCPA) greenhouse-gas reduction targets and the Town's Climate Smart Community commitments by making EV charging more affordable and encouraging cleaner transportation.

A draft is below:

Amendment of Electric Vehicle Charging Fee to At-Cost Rate
Introduced by Councilman Fantini, who moved its adoption, seconded by _____.

WHEREAS, the Town of Clifton Park has established electric vehicle charging stations operated through SWTCH, with a current charging fee of \$0.30 per kilowatt-hour; and

WHEREAS, this fee includes the Town's utility rate of approximately \$0.15 per kilowatt during peak periods, a 10% transaction fee applied by SWTCH to each charging session, and an additional \$0.15 per kilowatt to recover annual network and management service fees of \$240 per charger for the Town's twelve chargers; and

WHEREAS, New York State's Climate Leadership and Community Protection Act (CLCPA) establishes binding targets to reduce statewide greenhouse gas emissions 40 percent below 1990 levels by 2030 and 85 percent by 2050, and encourages local governments to support the transition to cleaner transportation alternatives to help achieve these goals; and

WHEREAS, many municipalities in the Capital Region, including Saratoga Springs, Voorheesville, Niskayuna, Albany, and the Glen Falls, currently provide free public EV charging at government-owned facilities; and

WHEREAS, to promote the adoption of electric vehicles and sustainable transportation, it is desirable to set the charging fee at the Town's direct variable costs for electricity and transaction fees, without including recovery of fixed annual service fees; now, therefore, be it

RESOLVED, that the electric vehicle charging fee be amended to \$0.165 per kilowatt-hour; and be it further

RESOLVED, that the Director of Planning & Zoning is authorized to make the above-stated amendment and implement the revised fee.

Add Supporting Docs:

Additional Comments/Details: NA

Agree to Terms: Agree

[unsubscribe](#)



RESOLUTION

#9

PHILIP C. BARRETT
Supervisor

AGATHA REID
Councilwoman

ZABED MANIR
Councilman

NANCY R. BELLAMY
Councilwoman

MARIO L. FANTINI
Councilman

Resolution No. __ of 2026, a resolution authorizing the Town Attorney to settle three Town lawsuits related to Highway paving and authorizing the Town to make payments to the three (3) litigants involved in the matter.

Introduced by _____, who moved its adoption, seconded by _____.

WHEREAS, by Resolution No. 6 of 2026, the Town Board resolved to settle litigation in regard to the Highway Department, paving bills, and the Superintendent of Highways, Dahn Bull, and

WHEREAS, additional sums for paving are owed to Evolution Construction, which has commenced legal action against the Town, and

WHEREAS, the highway fund currently has accrued \$412,031.29 in expenditures for Callanan Industries, and \$209,764.37 for Evolution Construction; now, therefore, be it

RESOLVED, that the Town Attorney is authorized to resolve, settle and make payment to Evolution Construction; and be it further

RESOLVED, that the Town Board authorizes payment of these paving bills and reimbursement of legal expenses related to the settlement of the matters and directs the Town Comptroller to issue payment to the following entities:

1. Callanan Industries - \$445,762.05
2. Evolution Construction - \$209,764.37
3. Highway Superintendent Dahn Bull - \$13,722

,and be it further

RESOLVED, that the additional amount due Callanan Industries of \$33,730.76 and the amount due Dahn Bull, \$13,722, be paid from a transfer from Unassigned Fund Balance (A-00914) with a transfer to A-05010-00025 (General Fund – Highway Administrative – Legal Fees; and be it further

RESOLVED, that the Town Attorney is authorized to enter into Stipulations settling the litigation with the three (3) above-referenced litigants.

Resolution No. 6 of 2026, a resolution in connection with the resolution of two lawsuits.

Introduced by Councilman Manir who moved its adoption, seconded by Councilwoman Bellamy.

WHEREAS, Callanan Industries, Inc., and Dolomite Products Company, Inc. (hereinafter referred to as Callanan) provided materials and paving services for the Town of Clifton Park costing approximately \$417,000, pursuant to valid 284 Agreement which had been approved by the Town of Clifton Park; and

WHEREAS, Clifton Park Town Supervisor Philip Barrett has refused to pay Callanan without legal justification; and

WHEREAS, Callanan has filed a lawsuit against the Town of Clifton Park seeking to be paid; and

WHEREAS, the Town of Clifton Park directed the Town Attorney to file a Third-Party Complaint against Clifton Park Town Highways Superintendent Dahn Bull; and

WHEREAS, there was no legal justification for filing the Third-Party Complaint; and

WHEREAS, the Town of Clifton Park wishes to resolve both lawsuits, now be it

RESOLVED, that the Clifton Park Town Attorney is hereby directed to take the steps necessary to withdraw the Town's Third-Party lawsuit against Clifton Park Town Highways Superintendent Dahn Bull; and be it further

RESOLVED, that the Clifton Park Town Highways Superintendent Dahn Bull is to be reimbursed by the Town for his reasonable attorney fees pursuant to Section 18 of the Public Officer's Law upon submission and review of the legal fees; and be it

RESOLVED, that the Clifton Park Town Attorney is hereby directed to take the steps necessary to settle the aforesaid lawsuit filed against the Town by Callanan.

ROLL CALL VOTE

Ayes: Councilwoman Bellamy, Councilman Fantini, Councilman Manir

Noes: Councilwoman Reid, Supervisor Barrett

DECLARED ADOPTED

January 6, 2026

Caitlin Fantini, Town Clerk



RESOLUTION

#10

PHILIP C. BARRETT
Supervisor

AGATHA REID
Councilwoman

ZABED MANIR
Councilman

NANCY R. BELLAMY
Councilwoman

MARIO L. FANTINI
Councilman

Resolution No. _____ of 2026, a resolution authorizing Blood Cancer United to hold a fundraiser at the Clifton Park Senior Community Center.

Introduced by _____, who moved its adoption, seconded by _____.

WHEREAS, Gautham Reddy Sagili, a sophomore at Shenendehowa High School and a member of Blood Cancer United's student visionary campaign, has requested permission to hold a bingo fundraiser on February 28, 2026, at the Senior Center, and

WHEREAS, Sue Leonard, Director of the Clifton Park Senior Community Center, has requested permission to waive the facility rental fee for Blood Cancer United's fundraiser event; now, therefore, be it

RESOLVED, that Gautham Reddy Sagili and Blood Cancer United are authorized to hold a bingo fundraiser on February 28, 2026, from 5:00pm-8:00pm, at the Clifton Park Senior Community Center: and be it further

RESOLVED, that the Senior Center Facility Rental Fee of \$60.00/hr is hereby waived.

Cynthia Zlogar

From: Town of Clifton Park Official Website <info@cliftonpark.org>
Sent: Wednesday, February 18, 2026 9:49 AM
To: Cynthia Zlogar; Phil Barrett; Jean Spiegel; Mark Heggen; Darlene Allen; Zabed Manir; Agatha Reid; John Scavo; Christine Pagnielo; Walter Smead; Kelly Miller; Nancy Bellamy; Mario Fantini; Kevin Dailey; Caitlin Fantini
Subject: New Resolution Request #2613

A new resolution request has been submitted. The details of this resolution request are included below.

Department: Senior Center
Your Name: Stacie Agostino
Your Email: sagostino@cliftonpark.org
Sponsor: P. Barrett
Agenda Session Date: 02/24/2026 ✓
Board Meeting Date: 02/24/2026 ✓
Alternate Date: 02/24/2026
Budget Number: NA
Budget Description: NA
Amount: NA
Brief Description: Request to waive rental fee for Gautham Reddy Sagili, Shen High School 10th grader hoping to hold fundraiser in the Community Room:

My name is Gautham Reddy Sagili and I am a 10th grader at Shenendehowa. I am a part of Blood Cancer United's student visionary campaign which runs for 7 weeks starting from January 15th to March 5th. During this campaign period, the goal is to raise as much money as possible all while raising awareness for different types of blood cancer. Our goal is to make sure no family has to face this terrible disease alone and that they know about the services that blood cancer united has to offer. All the money that we raise during this campaign period goes straight to helping patients pay for chemotherapy bills as well as transportation to hospitals.

Add Supporting Docs:

[0805789a8b0a917b_Gautham_fundraiser_2026_Rental_Agreement.pdf](#)

Additional Comments/Details: Rental agreement attached.

Agree to Terms: Agree

[unsubscribe](#)

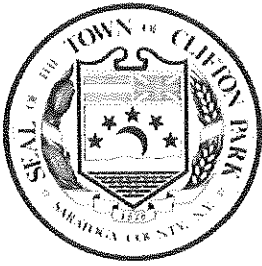

TOWN OF CLIFTON PARK

Clifton Park Senior Community Center

6 Clifton Common Court, Clifton Park, New York 12065 || ph: 518-383-1343

Facility Rental Agreement

Name of Organization: _____ Today's date: 2/18/26

Contact Person: Gautham Reddy Sagili

Address: _____ City: _____

Phone (home): _____ (cell) _____

Email: _____

Date of Rental: 2/28/26 Start Time: 5:00pm End Time: 8:00pm

Purpose of Event: Blood Cancer United: Bingo fundraiser

Number of Attendees: 50 Is your organization a 501(c)(3)? (proof required) _____

Rental is not guaranteed until payment and signed Agreement is received

Carry in, carry out policy in effect for all events. Checks made payable to: **Town of Clifton Park.**

Contact Information—Day of Rental—Town Security 518-369-6651

*Please complete and leave 1/2 sheet Rental Checklist on front desk (attached)

Description	Regular Rate	Non-Profit <small>*Must have a 501(c)(3)</small>	# of Hours	Fee
Security Deposit	\$100	\$100	-	
Community Room - Full Room	\$90 per hour	\$60 per hour	3	\$0
Community Room - Half Room	\$60 per hour	\$40 per hour		
Studio/Activity Room	\$60 per hour	\$40 per hour		
Creative Design Room	\$35 per hour	\$25 per hour		
Kitchen—advanced training required if using the stove or oven	\$90 per day	\$90 per day	-	
Room Set-up/ Break-down Fee (may be available upon request)	\$100 (if available)	\$100 (if available)	-	
Alcohol Permit	\$25	\$25	-	
Special Instructions:	Total Due:			
	Amount Paid:			
	Balance:			

Facility Rental Permit is governed by the following conditions:

- Permits valid for agreed upon date or dates, restricted to area/room (*the lobby is not rentable*), and number of participants as indicated on permit.
- All renters must provide a \$100 security deposit to be paid in full, with a separate check from the rental fee, **at the time of reservation**. The security deposit will be applied to any cleaning, theft, damages upon completion of the event and will be held in escrow and refunded upon completion of the rental. In the event of misconduct or the misuse of the facility by the lessee, the Town of Clifton Park may take action and require the renter to reimburse the Town for damages suffered or extra expenses incurred including, but not limited to, the forfeiture of a portion or the entire deposit.
- Cancellation requests less than 2 weeks of rental date will result in forfeiture of \$100 Security Deposit.
- Area and facility must be left clean and in the same condition in which it was found. Any damage incurred is the responsibility of the renter.
- Renter are not to use any rooms/areas of the building except what was rented, excluding restrooms.
- **All food/drink shall be removed at the conclusion of the event. The Town has a carry in carry out policy on garbage. All garbage shall be removed and placed in the proper receptacle located in the back of the building.**
- Smoking is not allowed in any part of the building. There is to be no open flames, i.e. candles, lanterns, allowed for use.
- On site supervision **is required** for all youth groups/events.
- At no time is the building/room occupancy to be exceeded and all fire doors and emergency exits must remain unblocked.
- Use of kitchen must be agreed upon in advance, requires an additional fee and training stove/oven.
- Town of Clifton Park rules shall be adhered to. Immediate termination of the event and removal from the premises may occur by an authorized representative of the Town if in violation of these rules and regulations.
- Obnoxious behavior or excessive noise will not be permitted.
- Renter must retain Rental Agreement and make available upon request by park or police official.
- Open containers of alcoholic beverages are prohibited in the building, unless a permit has been issued which allows for the consumption of alcoholic beverages on the premises for which the permit has been issued. Such permits are authorized solely by the Town Board via resolution. A separate "Special Alcohol Use Permit Request" form must be submitted with this form.
- Use of Center equipment (i.e. projectors, PA system, televisions, coffee maker, dishwasher, speakers, etc.) is strictly prohibited.
- Renters must clean up all spills and sweep debris from floors. Do not touch/play musical instruments without prior permission and do not handle the shades/blinds as they are delicate.
- Permit holder may be required to obtain and show proof of insurance naming Town of Clifton Park as an "Additional Insured".

I have read the Town of Clifton Park rules and the above special conditions and agree to abide by them. I understand there is a no refund policy on this rental. The Town will work with me on rescheduling when possible, if needed.

Indemnity:

_____ (Renter's Name) agrees to indemnify and hold the Town, it's officers, employees, representatives and/or agents harmless with respect to any and all claims, causes of action, suits, proceedings, damages, liabilities, losses, costs and expenses, including third party claims or actions and attorneys' fees, in connection with loss of life, personal injury and/or any loss of life, personal injury and/or property damage which may arise from and as a result of the negligent acts or omissions of _____ (Renter's Name) or others associated in some way therewith, during or arising out of the use of any park facility located in the Town of Clifton Park, County of Saratoga, State of New York on _____ (Rental Date).

SIGNED: _____ APPROVED: _____ DATE: _____
Permit Applicant



RESOLUTION

#11

PHILIP C. BARRETT
Supervisor

AGATHA REID
Councilwoman

ZABED MANIR
Councilman

NANCY R. BELLAMY
Councilwoman

MARIO L. FANTINI
Councilman

Resolution No. of 2026, a resolution authorizing the purchase of a 16-foot aluminum equipment trailer and a 12-foot tilt deck trailer for use by the Buildings & Grounds Department.

Introduced by _____, who moved its adoption, seconded by _____.

WHEREAS, Daniel Clemens, Director of Buildings, Parks and Recreation, solicited quotes for the purchase of a 16-foot enclosed aluminum trailer and a 12-foot tilt deck trailer, both for general use by the Buildings & Grounds department, and

WHEREAS, quotes were received from three sources for each trailer, and Griffin Motorsports submitted the lowest quote for the both pieces of equipment, and

WHEREAS, Mr. Clemens has advised that the 2026 16-foot Stealth Trailer enclosed hauler and the 2026 12-foot single axle tilt 7.8k trailer will meet the needs of the Buildings & Grounds department and are currently available from Griffin Motorsports, Schenectady, NY; now, therefore, be it

RESOLVED, that the Director of Buildings, Parks and Recreation is hereby authorized to purchase a 2026 Stealth Trailer enclosed aluminum hauler, model #C8.5X16SCH-XLT-P, in an amount not to exceed \$10,716, and a 12-foot single axle tilt trailer, model #ST-TSA7812-078, in an amount not to exceed \$6,198, both to be paid from A-7112-200 (General Fund – Clifton Common – Equipment).

Cynthia Zlogar

From: Town of Clifton Park Official Website <info@cliftonpark.org>
Sent: Thursday, January 22, 2026 11:24 AM
To: Cynthia Zlogar; Phil Barrett; Jean Spiegel; Mark Heggen; Darlene Allen; Zabed Manir; Agatha Reid; John Scavo; Christine Pagniello; Walter Smead; Kelly Miller; Nancy Bellamy; Mario Fantini; Kevin Dailey; Caitlin Fantini
Subject: New Resolution Request #2488

A new resolution request has been submitted. The details of this resolution request are included below.

Department: Buildings & Grounds

Your Name: Daniel Clemens

Your Email: dclemens@cliftonpark.org

Sponsor: P. Barrett

Agenda Session Date: 02/03/2026 ✓

Board Meeting Date: 02/24/2026 ✓

Alternate Date: 03/03/2026

Budget Number: A-7112-200

Budget Description: General Fund - Clifton Common - Equipment

Amount: 10,716.00

Brief Description: purchase (1) 8.5-foot x 16-foot enclosed equipment trailer from Griffin Motorsports.

Add Supporting Docs:

[0e2558c2b95f54fa_16-foot_enclosed_trailer_res_packet_1.22.26.pdf](#)

Additional Comments/Details: We have been looking at getting one enclosed trailer for the last few years. It will have many valuable uses in the department.

Agree to Terms: Agree

[unsubscribe](#)

Town of Clifton Park
Buildings & Grounds

Quote Cover Sheet

Date: January 22, 2026

Description: 8.5 x 16 - foot enclosed trailer

Vendor #1: Griffin Motorsports - \$10,716.00 ✱

Vendor #2: Outdoor Motor Sports & Trailer Sales - \$13,710.93

Vendor #3: Versatile Trailers - \$13,850.00

Vendor #4:

Vendor #5:

Vendor #6:

Comments:

Decision: Griffin Motorsports - \$10,716.00

GRIFFIN MOTORSPORTS

3909 State Street Schenectady, New York 12304
(518) 381-4883 • fax (518) 381-1029
www.griffinmotorsports.com

WORKSHEET / PROPOSAL

Facility #7068616

Tax ID #141771548

Enclosed 2

PURCHASER <i>Town of Clifton Park</i>			HOME PHONE	BUSINESS PHONE	DATE
STREET			DRIVER'S LIC. NO	BIRTH DATE	
CITY	STATE	ZIP	COUNTY		

DESCRIPTION OF PURCHASE				DESCRIPTION OF TRADE-IN		
<input type="checkbox"/> NEW <input checked="" type="checkbox"/> USED	<i>Stealth</i>	<i>8 1/2 X 16</i>	YEAR <i>26</i>	MAKE	MODEL	YEAR
SERIAL NO.				SERIAL NO.		
COLOR		ODOMETER		COLOR	ODOMETER	LIC OR TITLE NO.

ACCESSORIES			PURCHASE AGREEMENT		
				SALE PRICE	
				CLERICAL FEE	
				DEALER PREP	
				ACCESSORIES	
				EXTENDED SERVICE AGREEMENT	
				SUB-TOTAL	<i>10720</i>
				TRADE-IN ALLOWANCE	
				TAXABLE DIFFERENCE	
				_____ PERCENT SALES TAX	
				PAYOFF ON TRADE	
				DOCUMENTATION FEES	
				INSPECTION FEE	<i>6</i>
				WASTE TIRE MANAGEMENT FEE	<i>10</i>
				REGISTRATION	
				TOTAL PRICE	<i>10716 -</i>
				DOWN PAYMENT	
				BALANCE DUE	

"IF THIS MOTOR VEHICLE IS CLASSIFIED AS A USED MOTOR VEHICLE, THE ABOVE NAMED SELLER CERTIFIES THAT THE ENTIRE VEHICLE IS IN CONDITION AND REPAIR TO RENDER, UNDER NORMAL USE, SATISFACTORY AND ADEQUATE SERVICE UPON THE PUBLIC HIGHWAY AT THE TIME OF DELIVERY."

The customer certifies that he is 18 years of age or over and warrants that he is the true and lawful owner of the trade-in and that it is free of all encumbrances whatsoever except as noted above.

NOTE: All applicable sales tax has been collected.

This order is accepted subject to any and all price increases made by the factory before delivery.

Charges over \$1,000 on MasterCard, Visa, Discover subject to 2 percent surcharge.

Vehicle not returnable under any circumstances.

SALESPERSON _____

PURCHASER _____

DEALER ACCEPTANCE _____

CO-PURCHASER _____

1	1	EACH	C8.5X16SC H-XLT-P	<p>STEALTH 8.5X16 Car Hauler XLT Pro Series</p> <p>All-Aluminum Construction Integrated Frame One-Piece Aluminum Roof Beavertail Construction 2"x5" Subframe Tubing 16" O/C Walls, Roof & Floor Studs Box Length: 16' Box Width: 99" Interior Height: 82" Rear Door Opening WxH: 91"x79" 36" V-Nose Construction *** NO ANODIZED NOSE CONE *** 24" Stoneguard 5000# Center Jack Axles: 2-3500# Braked Leaf Spring w/ 4" Drop GVWR: 7000# Tire:15" Gloss Black Mods 205/75R15 (4) HD 5,000# Recessed D-Rings Car Hauler Grade Rear Ramp w/Spring Assist, Starter Flap & Aluminum Hardware 32"x72" Side Access Door w/ Paddle Handle & Piano Hinge Plastic Salem Vents (1) Interior Dome Light near SAD (No Wall Switch) LED Slimline Stop/Turn/Tail Lights LED ID Marker Light Bar (Top/Center Bulkhead) Exterior LED Lighting 3/4" Water Resistant Decking 3/8" Water Resistant Interior Walls Interior Cove Trim Package 2-5/16" Coupler w/ (2) Safety Chains .030 Screwless Skin, Bonded on Seams 3" Exterior Trim 4-Year Limited Warranty SIDE DOOR: CURBSIDE FRONT COLOR: ??????</p>
---	---	------	----------------------	---

10700
**PLEASE REVIEW

Order App



Quote



1355 Oak Hill Rd
Mountain Top, PA 18707
P: 570-474-1280
F: 570-474-1285

Table with 2 columns: Sold To, Ship To. Both columns list Versatile Trailers, 786 Rte 9, Gansevoort, NY 12831.

Table with 3 columns: Item, Model, Qty. Item: 8.5 x 16 Element SE Flat Top Sloped V-Nose Car Hauler 14K(White). Model: K-SEC10216-140. Qty: 1.

Standard Features Per Trailer:

- Frame: 8" x 2" Steel Tube
Crossmembers: Formed Steel, 16" On-Center
Tongue: 8" x 2" Steel Tube with Center Drawbar
Integrated Step(s): Interior Recessed
Coupler: 2-5/16" A-Frame
Safety Chains: DOT Compliant
Tongue Jack: 5K Coupler Mounted
Wall Studs: Steel Tube, 16" On-Center
Roof Bows: Steel Tube, 16" On-Center
Front Profile: 30" Sloped V-Nose with 6" Drop
Beavertail: 32"
Ramp(s): 4000 lb. with Assist
Ramp(s): 16" Extension
Side Door: 36" Wide Flush Lock
Side Door: Cast Aluminum Holdback
Vents: Sidewall Airflow
Axle: (2) 7000 lb. Drop Spring Brake
Hubs: Easy Lube
Breakaway: Battery, Switch, and Lanyard
Tires: ST235/80R16E 10-PR
Wheels: 16", 8-Hole Steel
Wheels: Stainless Center Caps
Exterior Finish: Piedmont .080" Composite Panels
Undercoating: Asphalt Emulsion
Exterior Fastening: Screwless Sidewalls
Exterior Trim: 2.7" Top Extrusion
Exterior Trim: 2.7" Bottom Extrusion
Exterior Trim: ATP Nose Cap
Exterior Trim: Brite Aluminum Corners
Exterior Trim: Brite Aluminum Rear Hoop
Stone Guard: 24" ATP
Roof: Translucent Roof
Interior Walls: Engineered Wood
Interior Trim: Aluminum H-Channel Wall Transitions
Flooring: 3/4" Engineered Wood
Interior Lights: (2) LED
Switches: (1) Dome Light, 12V
Cargo Control: (4) 5000 lb. Recessed D-Rings
Connector Plug: Round 7-pin Blade
Exterior Lights: Full LED, DOT Compliant
Exterior Lights: Integrated Backup/Taillights
Warranty: Limited 3-Year Warranty
Standard Interior Height: 84"

Table with 4 columns: Standard Interior Height, Interior Width, Rear Opening Height, Rear Opening Width. Values: 84.00, 97.00, 85.00, 93.50.

Selected Options Per Trailer:

Table with 3 columns: Option Name, Code, Qty. Options include Color, White; Upgrade Crossmembers; Double Existing 3/4" Engineered Wood Flooring; Ramp Door Upgrade; Aluminum Tread Plate; D-Ring (5000lb) w/ Steel Plate.

For Total of 6 D-rings
2 Front, 2 Center, 2 Rear

Surcharge - Mountain Top, PA (8%)

SURCHARGE-LMT

Handwritten notes: 13950 - plus tax MD/PA fees

2025 HIGH COUNTRY 102"X16' XPRESS ENCLOSED CARGO

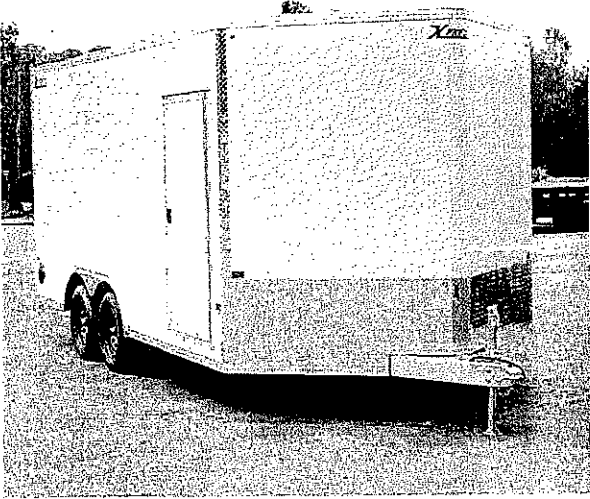

Vin

5WFBE1629SW151128

Salesperson

tom lee

UNIT INFO

Category: Enclosed Cargo

Year: 2025

Brand: High Country

Model: 102"X16' XPRESS

Stock #: 151128

Condition: New

Color: WHITE

Length: 16ft0in

Width: 0ft102in

Weight: 1981

GVWR: 7000

Pull Type: Bumper Pull

All prices and financial promotions are subject to change without notice. Trade-in values are estimates only and are subject to final inspection and approval. While we strive for accuracy, this sales sheet may contain errors or omissions. We are not responsible for any inaccuracies and disclaim any liability for damages resulting from reliance on this information. This price is only good for today, December 22, 2025.

MSRP:	\$12,799.00
Freight:	+\$0.00
Delivery Fee:	+\$0.00
Trade-In:	-\$0.00
Accessories:	+\$0.00
Subtotal A:	\$12,799.00
Tax (7%):	+\$895.93
Subtotal B:	\$13,694.93
NYS Reg:	+\$0.00
Doc Fee:	+\$0.00
Inspection:	+\$6.00
NYS Tire Tax:	+\$10.00
Pre-Rebate Total:	\$13,710.93
Rebate:	-\$0.00
Out The Door Price:	\$13,710.93

OUTDOOR MOTOR SPORTS & TRAILER SALES

3953 NY-30, Amsterdam, NY

Call or Text: 518-842-8812

Outdoor-Motor-Sports.com

NOTES

Cynthia Zlogar

From: Town of Clifton Park Official Website <info@cliftonpark.org>
Sent: Thursday, January 22, 2026 11:29 AM
To: Cynthia Zlogar; Phil Barrett; Jean Spiegel; Mark Heggen; Darlene Allen; Zabed Manir; Agatha Reid; John Scavo; Christine Pagniello; Walter Smead; Kelly Miller; Nancy Bellamy; Mario Fantini; Kevin Dailey; Caitlin Fantini; hd
Subject: New Employee Resolution Request #2489

A new employee resolution request has been submitted. The details of this resolution request are included below.

Department: Buildings & Grounds
Your Name: Daniel Clemens
Your Email: dclemens@cliftonpark.org
Sponsor: P. Barrett
Agenda Session Date: 02/03/2026 ✓
Board Meeting Date: 02/24/2026 ✓
Alternate Date: 03/03/2026
Budget Number: A-7112-200
Budget Description: General Fund - Clifton Common - Equipment
Amount: \$6,198.00
Brief Description: purchase (1) 6.5-foot x 12-foot tilt deck trailer from Griffin Motorsports
Add Supporting Docs:

[cb299ab541683c92_12-foot_tilt_trailer_res_packet_1.22.26.pdf](#)

Additional Comments/Details: We will use this when a small crew is out with small equipment. For example, using a Dingo or Blower. Also will be used to transport our scissor lift.

Agree to Terms: Agree

[unsubscribe](#)

Town of Clifton Park
Buildings & Grounds

Quote Cover Sheet

Date: January 22, 2026

Description: 12-foot tilt trailer

Vendor #1: Griffin Motorsports - \$6,198.00 *

Vendor #2: Anderson Boats - \$6970.00

Vendor #3: Versatile Trailers - \$8,615.00 (14-foot - 12 not available)

Vendor #4:

Vendor #5:

Vendor #6:

**Comments: This will be used to transport our small machines
for example: Dingo, Hurricane blower, Mud buggy, side by side**

Decision: Griffin Motorsports - \$6,198.00

GRIFFIN MOTORSPORTS

3909 State Street Schenectady, New York 12304
(518) 381-4883 • fax (518) 381-1029
www.griffinmotorsports.com

WORKSHEET / PROPOSAL

Facility #7068616
Tax ID #141771548

T.H. 1

PURCHASER <u>Town of Clifton Park</u>			HOME PHONE	BUSINESS PHONE	DATE
STREET			DRIVER'S LIC. NO	BIRTH DATE	
CITY	STATE	ZIP	COUNTY		

DESCRIPTION OF PURCHASE				DESCRIPTION OF TRADE-IN		
NEW OR USED	MAKE	MODEL	YEAR	MAKE	MODEL	YEAR
	<u>Subaru</u>	<u>Outback</u>	<u>06</u>			
SERIAL NO. <u>T.H.</u>				SERIAL NO.		
COLOR		ODOMETER		COLOR	ODOMETER	LIC OR TITLE NO.

ACCESSORIES			PURCHASE AGREEMENT		
<u>28k</u>				SALE PRICE	
				CLERICAL FEE	
				DEALER PREP	
				ACCESSORIES	
				EXTENDED SERVICE AGREEMENT	
				SUB-TOTAL	<u>6187</u>
				TRADE-IN ALLOWANCE	
				TAXABLE DIFFERENCE	
				_____ PERCENT SALES TAX	
				PAYOFF ON TRADE	
				DOCUMENTATION FEES	
				INSPECTION FEE	<u>6</u>
				WASTE TIRE MANAGEMENT FEE	<u>5</u>
				REGISTRATION	
				TOTAL PRICE	<u>6198</u>
				DOWN PAYMENT	
				BALANCE DUE	

"IF THIS MOTOR VEHICLE IS CLASSIFIED AS A USED MOTOR VEHICLE, THE ABOVE NAMED SELLER CERTIFIES THAT THE ENTIRE VEHICLE IS IN CONDITION AND REPAIR TO RENDER, UNDER NORMAL USE, SATISFACTORY AND ADEQUATE SERVICE UPON THE PUBLIC HIGHWAY AT THE TIME OF DELIVERY."

The customer certifies that he is 18 years of age or over and warrants that he is the true and lawful owner of the trade-in and that it is free of all encumbrances whatsoever except as noted above.

This order is accepted subject to any and all price increases made by the factory before delivery.

Charges over \$1,000 on MasterCard, Visa, Discover subject to 2 percent surcharge.

Vehicle not returnable under any circumstances.

NOTE: All applicable sales tax has been collected.

[Signature]
SALESPERSON

PURCHASER

DEALER ACCEPTANCE

CO-PURCHASER

Customer Quote



Quote :	DQT326898
Entry Date :	01/08/2026
Sales Rep :	Bob Griffin
Email :	bgriffin@griffinmotorsports.com

Quote By	Quote To
Griffin Motorsports 3909 State St. Schenectady NY, USA 12304 F: 1-518-381-1029 P: 518-381-4883	Town of Clifton Park

Item	Model	Qty
6.5 x 12 Single Axle Tilt 7.8K	ST-TSA7812-078	1

Standard Features

Frame : 5" x 2" Steel Tube	Fenders : Square Rolled Steel Tread Plate	Decking : 2" Pressure Treated Pine
Crossmembers : 3" Steel Channel, 16" On-Center	Axle : 7000 lb. Torsion Brake	Tie Downs : (4) 1/2" D-Rings
Tongue : 5" x 2" Steel Tube	Hubs : Easy Lube	Tie Downs : Stake Pockets and Rub Rail
Coupler : 2-5/16" Adjustable	Breakaway : Battery, Switch, and Lanyard	Exterior Storage : A-Frame Steel Lockable Toolbox
Safety Chains : DOT Compliant	Tires : ST235/80R16E 10-PR	Connector Plug : Round 7-pin Blade
Tongue Jack : 7K Drop Leg, Set-Back	Wheels : 16", 8-Hole Steel	Exterior Lights : Full LED, DOT Compliant
Bulkhead : HD Tube	Exterior Finish : Industrial Grade Polymer Finish	Hydraulic Components : Hydraulic Cushion Load Cylinder
Ramp(s) : HD Diamond Plate Knife Edge Tail		

Selected Options

Color Standard, Black	UPGBLK	1
-----------------------	--------	---

\$6187



LIKE OUR FB PAGE TO SEE OUR DAILY SPECIALS!

FACEBOOK
(HTTPS://WWW.FACEBOOK.COM/ANDERSENBOATNY/)



883 ROUTE 50
BURNT HILLS, NY 12019
(HTTPS://MAPS.APP.GOO.GL/VHJ05QMHAUCB)

(https://andersenboat.com/)

HOME SALES SERVICE PARTS FINANCING WARRANTY DOCKS DEALER INFO

CAR/EQUIPMENT TRAILER (HTTPS://ANDERSENBOAT.COM/TRAILER-TYPE/CAR-HAULER/) / 2025 K-TRAIL GALVANIZED TILT TRAILERS GT12 7'X12' 7KLBS

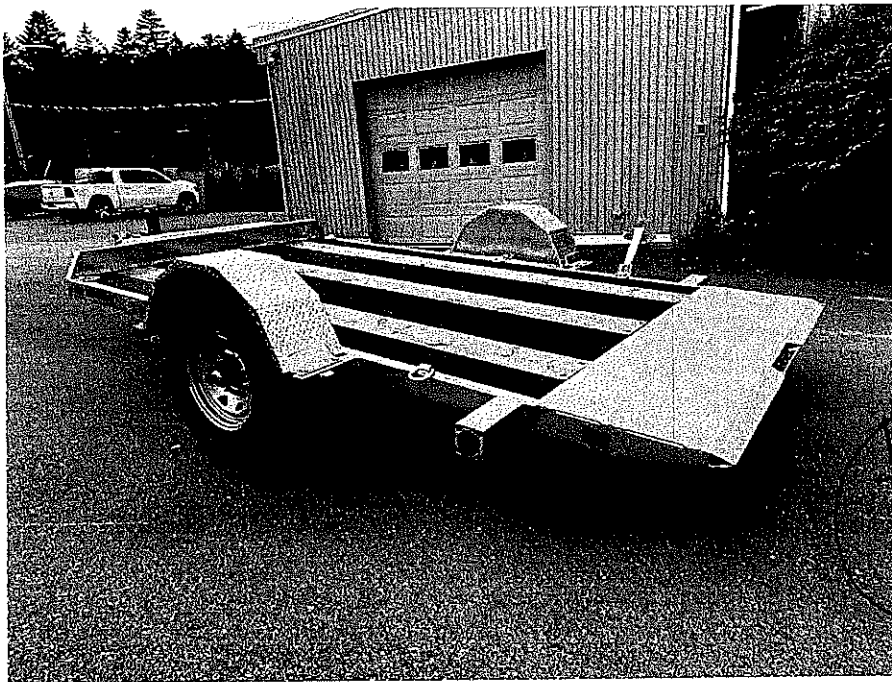

~~8990~~
#6500
#175
#295
②
#6970



ANDERSEN BOATS IN BURNT HILLS, NY

(518) 399-5003 (tel:+15183995003)

CAR/EQUIPMENT TRAILER (HTTPS://ANDERSENBOAT.COM/TRAILER-TYPE/CAR-HAULER/), TILT DECK (HTTPS://ANDERSENBOAT.COM/TRAILER-TYPE/TILT-DECK/)

CALL FOR PRICING

Financing from \$127 / mo. ⁱ

Instant - No credit impact

GET PREQUALIFIED (HTTPS://ANDERSENBOAT.COM/CREDIT-FINANCING-BOATS-DEALERSHIP-FINANCING/?STOCKNUMBER=42551&PRICE=6500)

Contact Us

REQUEST MORE INFORMATION

x

CONTACT US

First Name: Last Name:
First Name: Last Name:
Email: Phone:
Email: Phone:

Preferred Contact Method:
 Text Email Both
Preferred Contact Method:
 Message Email Both

Message:

I agree to receive text messages from Andersen/A&S Sales and Service. Message and data rates may apply. Reply STOP to unsubscribe.

I agree to receive text messages from Andersen/A&S Sales and Service. Message and data rates may apply. Reply STOP to unsubscribe.

SEND MESSAGE

SEND MESSAGE

Condition:		New
Width (FT):		6
Length (FT):		12
Status:	AVAILABLE	
Stock Number:	42551	
VIN:	2RYKBTE19SM042551	
Color:	GALVANIZED	
Axles:	1	
Payload:	5000 lbs	
GVWR:	7000 lbs	

[Unit Details](#) [Unit Specs](#) [Calculate Payments](#) [Value Your Trade](#)

the perfect K-Trail Tilt Trailers for you in our showroom near Albany, NY. Visit Andersen Boats, Trailers & Powersports, New York's premier K-Trail dealership.

ANDERSEN BOATS, TRAILERS & POWERSPORTS

Address: 883 Route 50, Burnt Hills, NY 12027

(<https://www.google.com/maps/place/Andersen+Boats,+Trailers+%26+Powersports/@42.9221612,-73.8836508,15z/data=!4m2!3m1!1s0x0:0xc1128d96cd554bfc?sa=X&ved=1t:2428&hl=en&ictx=111>)

Phone: (518) 399-5003 ([https://www.google.com/search?](https://www.google.com/search?sa=X&sca_esv=01ac707ed031b98c&sca_upv=1&rlz=1C1CHBF_enUS878US878&sxsr=ADLYWIL3OS7onqo9_JOraDElpMEd5G)

[sa=X&sca_esv=01ac707ed031b98c&sca_upv=1&rlz=1C1CHBF_enUS878US878&sxsr=ADLYWIL3OS7onqo9_JOraDElpMEd5G](https://www.google.com/search?sa=X&sca_esv=01ac707ed031b98c&sca_upv=1&rlz=1C1CHBF_enUS878US878&sxsr=ADLYWIL3OS7onqo9_JOraDElpMEd5G))

MULTIPLE FINANCING OPTIONS

CLICK HERE TO FIND THE ONE THAT'S RIGHT FOR YOU! ([HTTPS://ANDERSENBOAT.COM/CREDIT-FINANCING-BOATS-DEALERSHIP-FINANCING/](https://ANDERSENBOAT.COM/CREDIT-FINANCING-BOATS-DEALERSHIP-FINANCING/))

Customer Quote



Vince

Quote By

Versatile Trailers
 786 Rt 9
 Gansevoort NY, United States 12831
 F: (518)584-4379
 P: 518-584-6960

Quote To

Item

7 x 14 Tilt 11K

Model

P-FTT8214-110

Qty

1

Standard Features

Frame : 6" x 4" x 5/16" Steel Angle
 Crossmembers : 3" Steel Channel
 Tongue : 5" Steel Channel
 Coupler : 2-5/16" Adjustable
 Tongue Jack : 7K Drop Leg, Set-Back
 Ramp(s) : HD Diamond Plate Knife Edge Tail
 Fenders : Double Break Tread Plate

Axle : (2) 5200 lb. Slipper Spring Brake
 Hubs : Easy Lube
 Breakaway : Zip™ Cable and Switch, Battery, and Solar Charger
 Tires : ST225/75R15D 8-PR
 Wheels : 15", 6-Hole Steel
 Exterior Finish : Industrial Grade Polymer Finish
 Decking : 2" Pressure Treated Pine

Tie Downs : (4) 5/8" D-Rings
 Tie Downs : Banjo Tie-Downs
 Exterior Storage : Spare Tire Carrier
 Connector Plug : Round 7-pin Blade
 Exterior Lights : Full LED, DOT Compliant
 Hydraulic Components : Hydraulic Cushion Load Cylinder with Stop Valve

Selected Options

Color, Black

PUPGBLK

1

Quote may change.

\$ 3615 - plus tax + EMV fees.



RESOLUTION

#12

PHILIP C. BARRETT
Supervisor

•

AGATHA REID
Councilwoman

ZABED MANIR
Councilman

•

NANCY R. BELLAMY
Councilwoman

•

MARIO L. FANTINI
Councilman

Resolution No. _____ of 2026, a resolution authorizing the purchase of a Mohawk TR-19, 19,000 lb. 4-post lift from Mohawk Lifts LLC.

Introduced by _____, who moved its adoption, seconded by _____.

WHEREAS, Daniel Clemens, Director of Buildings, Parks and Recreation, advises of the need for a 4-post lift to replace the department's older 2-post lift, and that the 4-post lift will be able to handle every department truck, as well as the Senior Van buses, when repairing and servicing these vehicles, and

WHEREAS, Mr. Clemens has recommended the equipment be purchased from Mohawk Lifts LLC, under NYS Contract #PC7072858, in an amount not to exceed \$51,928; now, therefore, be it

RESOLVED, that the Town Board hereby authorizes the Director of Buildings, Parks and Recreation to purchase the 4-post lift from Mohawk Lifts, LLC, under NYS Contract #PC7072858, in a total amount not to exceed \$51,928, to be paid with a transfer from A-7112-200 (General Fund – Clifton Common – Equipment) to A-7110-200 (General Fund – Buildings & Grounds – Equipment).

Cynthia Zlogar

From: Town of Clifton Park Official Website <info@cliftonpark.org>
Sent: Wednesday, January 28, 2026 1:48 PM
To: Cynthia Zlogar; Phil Barrett; Jean Spiegel; Mark Heggen; Darlene Allen; Zabed Manir; Agatha Reid; John Scavo; Christine Pagniello; Walter Smead; Kelly Miller; Nancy Bellamy; Mario Fantini; Kevin Dailey; Caitlin Fantini
Subject: New Resolution Request #2523

A new resolution request has been submitted. The details of this resolution request are included below.

Department: Buildings & Grounds

Your Name: Daniel Clemens

Your Email: dclemens@cliftonpark.org

Sponsor: P. Barrett

Agenda Session Date: 02/03/2026 ✓

Board Meeting Date: 02/24/2026 ✓

Alternate Date: 03/03/2026

Budget Number: A-7110-200

Budget Description: General Fund - Buildings & Grounds - Equipment

Amount: \$51,928

Brief Description: Purchase (1) Mohawk TR-19 19,000 lb. 4-post lift and have it installed in the B&G shop to replace the old 2-post 10,000 lb. lift. This lift will handle every truck we have and the senior busses, which our 2-post can not.

Add Supporting Docs:

[03e68eb2cab1b7b5_4-post_Mohawk_lift_res._packet_1.28.26.pdf](#)

Additional Comments/Details: will need to include a budget transfer for this please.

From A-7112-200 Clifton Common - Equipment to A-7110-200 Buildings & Grounds - Equipment

Agree to Terms: Agree

[unsubscribe](#)

TERMS AND CONDITIONS

- 1) This order is subject to the Terms and Conditions of New York Contract #PC7072858
- 2) A fork truck must be supplied at the offload site to unload the equipment from the freight carrier and, if applicable, for installation.
- 3) The Customer is responsible for inspecting all Products at the time of delivery and before signing the delivery receipt, freight bill, or bill of lading. Should the customer determine at the time of delivery that any items are damaged or missing the Customer must note the item, discrepancy, or condition on the delivery receipt, freight bill, or bill of lading. Mohawk is not responsible for missing or damaged products when the Customer has signed the delivery receipt, freight bill, or bill of lading in good condition. If equipment is refused at time of delivery or returned as undeliverable, shipping costs and restocking fees may apply. Standard commercial packaging applies.
- 4) Quoted installation does not include electrical hook-up or any concrete work which may be required. Electrical and any concrete work that may be required must be performed prior to installer's appointment date.
- 5) Quoted Installation does not include any unforeseen circumstances such as plumbing, electrical, in floor heat, rebar, steel structures, drain, or drain slopes in the existing floor. Installation price is subject to change if the lift is unable to be installed at the time of scheduled appointment, if the shop condition is not ready for installation (lack of adequate concrete, no electrical service, etc), or any other condition which would require additional return trips by the installer.
- 6) Price does not include Sales tax (unless applicable), duties, brokerage, or any other fees. Down Payments are Non-refundable.
- 7) Any and all permits, licenses, fees, etc. are the Customers' responsibility.
- 8) If installation cannot be performed at the time of delivery, then equipment must be paid within terms specified from invoice date. Installation charge to be paid when service is performed.

DUNS: 117797939 / CAGE CODE: 8VDK6 / UEI: F9QME4G11RT5 / FEIN: 85-3221959 / SMALL BUSINESS SAM REGISTERED

Quote# Clifton.Park.BG.DC.NYSOGS.RP.1.19.26

v12.25

To place your order using this quotation, please fill in the following required information:

BILLING INFORMATION

SHIPPING INFORMATION

Same as

Name: _____	Name: _____
Address: _____ _____	Address: _____ _____
Contact: _____	Contact: _____
Phone: _____	Phone: _____
Email: _____	Email: _____
Delivery Hours/Instructions: _____	

Acknowledged and Accepted by:

Authorized Buyers Name (PRINT)

Authorized Buyers Signature

Title

Date

Phone

Email

Remit orders to:

MOHAWK LIFTS LLC

PO Box 110, Amsterdam, NY 12010

ORDERS@MOHAWKLIFTS.COM

BUY ONCE. BUY RIGHT. BUY A MOHAWK!

MODEL TR-25

25,000 LB 4 POST RUNWAY LIFT



*Because Quality Lifts
Last a Lifetime*

Americas Best Lift Investment...

MOHAWK LIFTS



MOHAWK LIFTS MODEL TR-25

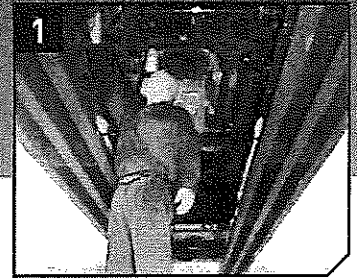

▲ Full under-vehicle access with no obstructions. Rolling jacks allow tires to raise off runways.

The Big Red One

For All Your Shop's Lifting Needs



Still proudly designed, welded and manufactured in the U.S.A.

MOHAWK ABOVE GROUND DESIGN

- Surface mounted operation avoids the environmental liabilities and service problems associated with in-ground lifts.
- Indoor or outdoor installation is quick & easy.
- Four post design allows complete under-vehicle access for all types of repair without side obstructions like scissors and parallelogram lifts.
- Clear floor unobstructed design allows tool boxes, jacks, and other shop equipment to roll freely between the posts.
- Standard 24" wide runways allow greater access for under-vehicle repair **giving 48" of clear span access.**
- Diamond plate covered approach ramps and runways assure additional traction and infinitely longer service life than traction "coated" textured paint.

COMPARE DESIGN FEATURES & CONSTRUCTION

- 16'9", 20', 25' or 30' runways are made from two or three parallel 8" steel I beams. (Three I beams on 30' model).
- Heavy duty 7" x 5" structural steel cross rails.
- Large 10" x 6" top rail is reversible to either driver or passenger side.
- Chain drive - no stretch or fray like cable lifts.
- Specially designed, double sealed, self-lubricating, hardened steel rollers at all chain pivot points.
- Full 3 year warranty (excluding motor/pump)

PROUDLY MADE IN THE USA SINCE 1981

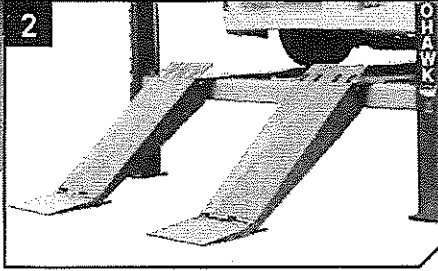

▲ Shallow angle approach ramps are 24" wide for easy drive on with the ability to accommodate a wide variety of vehicles (including low floor busses.) Shorter/longer or moveable ramps upon request.

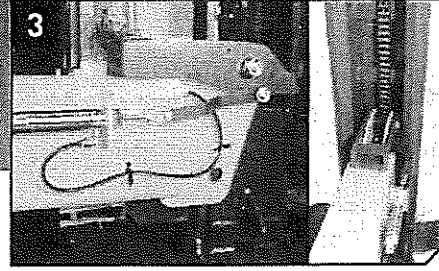

▲ Mohawk's all-position safety locks engage every 6" and continue to full lifting height.

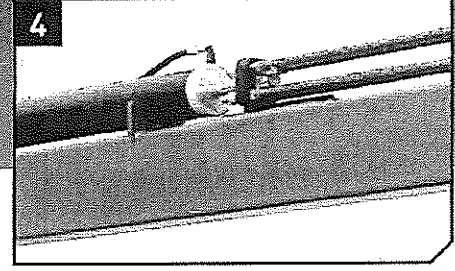

▲ Large 5" chrome plated cylinder with leaf chain drive system eliminates stretch, fray, pulleys and maintenance associated with cable driven lifts.

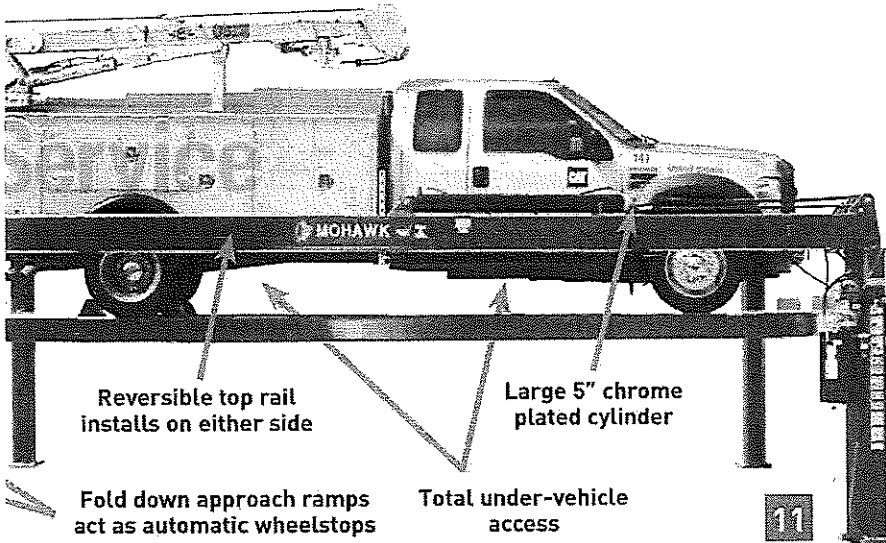

Reversible top rail installs on either side

Large 5" chrome plated cylinder

Fold down approach ramps act as automatic wheelstops

Total under-vehicle access

11

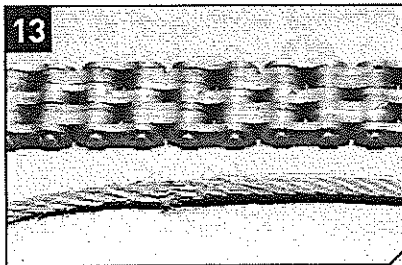

▲ #646 HIGH STRENGTH leaf chain compared to the competitive cables which fray

FEATURES

- 24" wide runways allow full service to all types of cars, vans, trucks, and busses, without having to adjust the tracks.
- Full 5'9" lifting height at top of tracks for tall technicians.
- Adjustable runways accommodate any vehicle up to 25,000 lbs.
- Optional 15,000 or 25,000 lb. capacity wheels free jack locks in place upon positioning.

SUPERIOR SAFETY SYSTEMS

- Multi-position mechanical locks in all four positions.
- Hydraulic safeties using pressure-compensated flow control valves and tamper-proof velocity fuses.
- Single position, two hand air operated release for safe lowering.
- Mechanical chain synchronization.
- The heaviest construction of any competitive lift. Just compare!

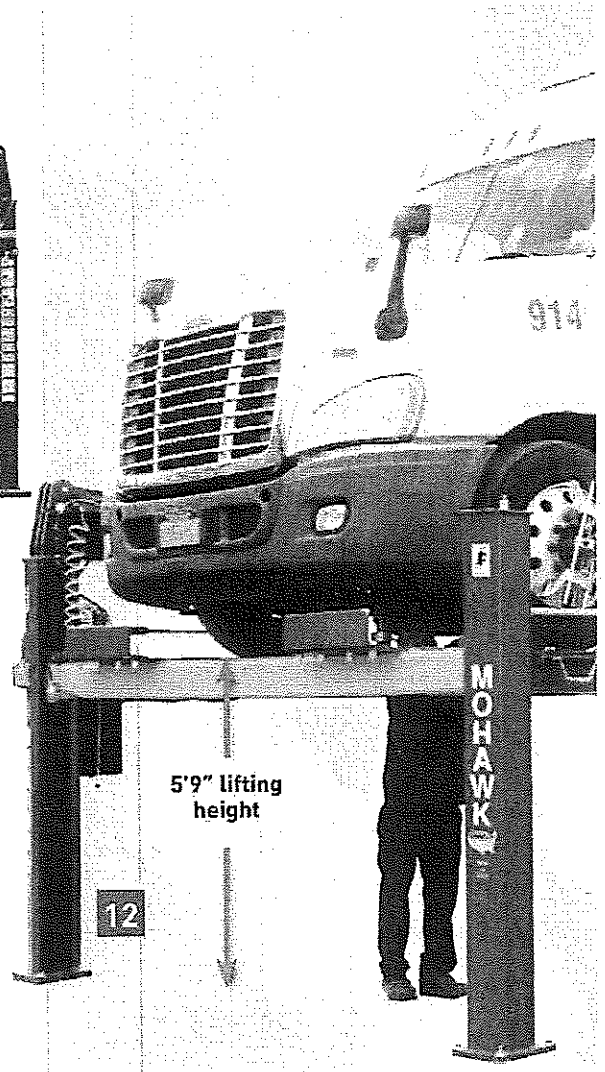

5'9" lifting height

12

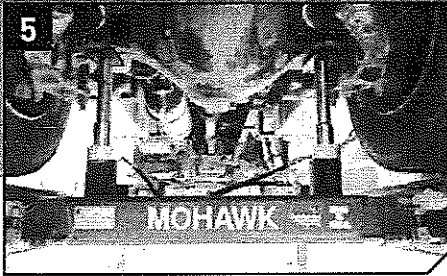

5 Mohawk's Rolling Jack: 15,000 or 25,000 lb. capacity rolling electric/hydraulic low profile jacks for "wheel free" tire and brake service. Jacks roll the full length of the runway, or use two jacks to raise the entire vehicle off of the runways. Mohawk's rolling jacks lock in place when loaded.

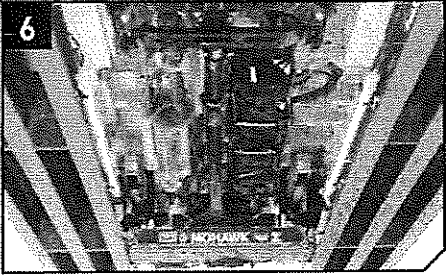

6 Shatter Proof LED Track Lighting: Optional shatter proof track lighting to brighten up the darkest vehicle undercarriages.

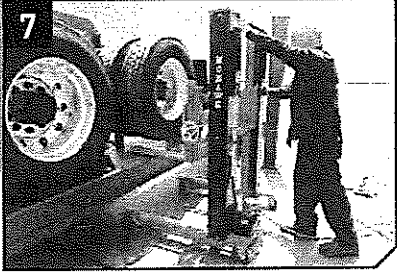

7 Tire Dolly Model TD-1800 or TD-2000: 1,000 or 2,000 lb. capacity for use with any above or in-ground lift, high 46" lifting height and 6" side shifting ability makes alignment simple.

ALIGNMENT COMPATIBLE

To verify alignment at any working height.



Shallow profile approach ramps assures easy access for even the lowest-riding vehicles

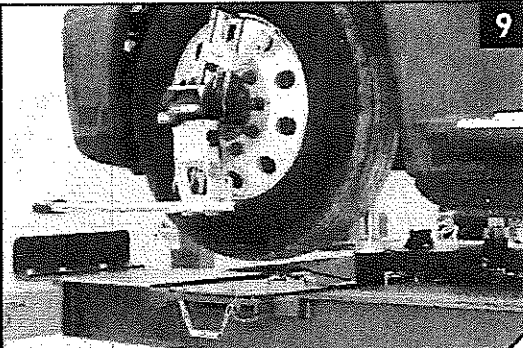

TR-25 alignment lift shown with alignment plates and tires raised off of runways

HOW DO YOU LIKE YOUR LIFT MADE?

- Chains, not cables
- I- Beams Tracks, not sheet metal
- Bearings, not bushings
- Diamond plate, not textured paint

14

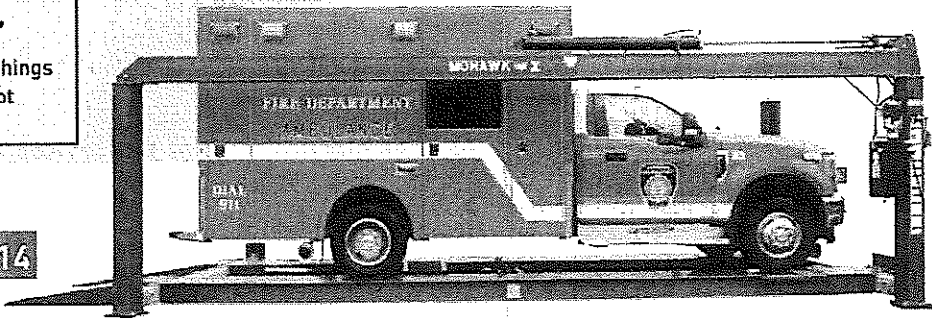

MOHAWK TR-SERIES FOUR POST LIFT OPTIONS

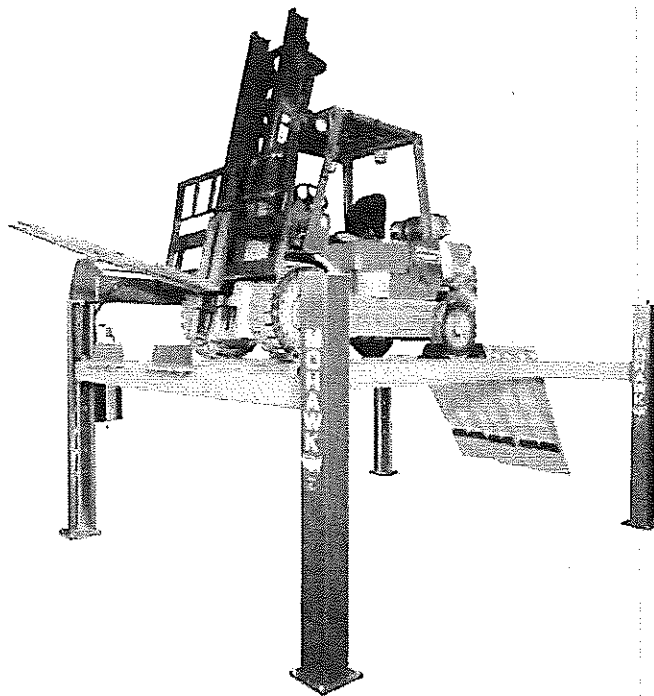
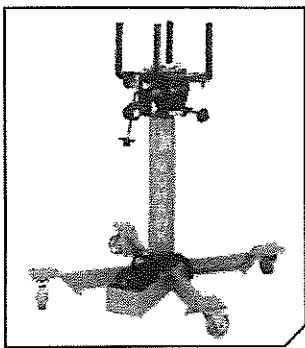
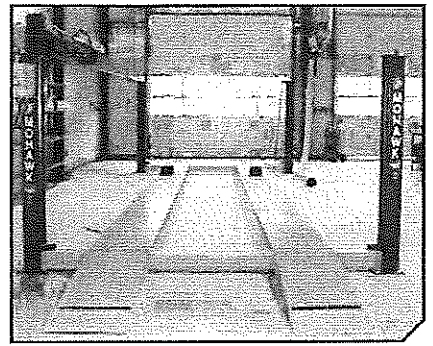
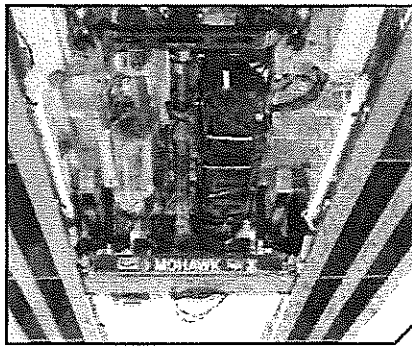
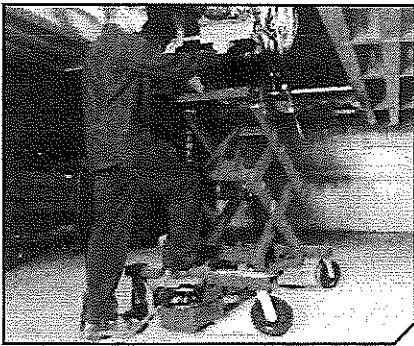
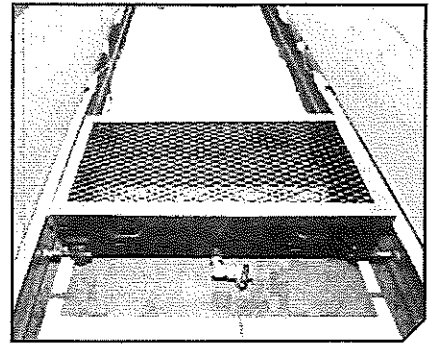
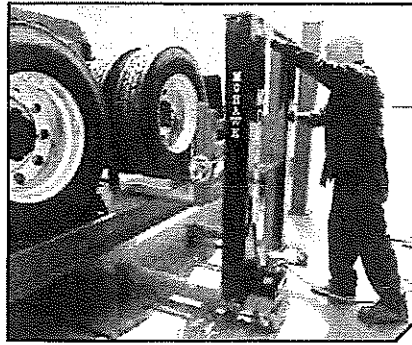
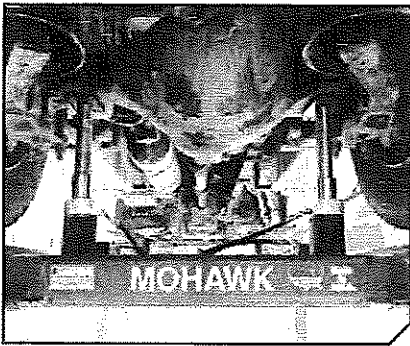

MODEL TR-25 SPECIFICATIONS

Capacity:	25,000 lbs.
Lifting Speed:	120 seconds
Motor Rating:	2 HP/220 V Single-Phase (3 phase optional)
Lifting Mechanism:	5" Hydraulic Cylinder Attached to (4) #646 Leaf Chains
Overall Length:	27'-3" (with 20' runways)
Track Length:	16'9", 20' 25' or 30'
Overall Width:	12' 6"
Lifting Stroke:	5'
Height @ Full Stroke:	5' 9 5/16" (top of runways)
Track Width:	24"
Track Adjustment:	4' to 8'
Clearance Between Posts:	11' Standard (Wider Available)
Mechanical Safety Release:	Single Point
Mechanical Safety Locks:	Multi-Positions
Back-Up Hydraulic Safety Systems:	Pressure Compensated Flow Controls & Velocity Fuses
Concrete requirements:	4000 PSI concrete 4 1/2" thick floor
Warranty:	3 years; (Excluding Motor/Pump)
Lift Weight:	5250 lbs (with 20' tracks)

Available Options

- 3' track extensions: front, rear, or both
- 3 phase power:
208/230 3 phase 60 hz/460 volt 3 phase 60 hz
380 volt 3 phase 50 hz/575 volt 3 phase 60 hz
- Alignment turntable cut outs in tracks
- Rolling hydraulic jacking beam
- Rolling jacking platform
- Air lines plumbed into tracks
- Obstacle sensor package
- 115 volt duplex outlet
- Runway lighting
- Lockable main switch
- Electric solenoid down valve
- Audible descent alarm
- Drive through ramps
- 25 gallon rolling oil drain pan

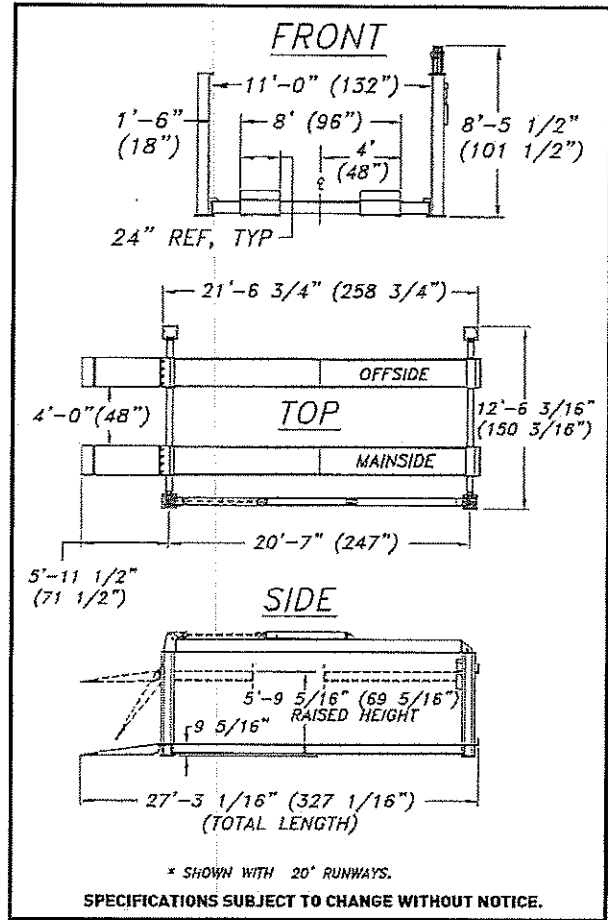

National Stock Number 4910-01-424-8934 (NSN)
 AS SEEN IN GSA ADVANTAGE

SIN #253-23 • CAGE CODE-OC714 • DUNS #10-128-9916

Mohawk builds the best products with the finest materials, to the highest standards. Just compare our lifts. Our staff will assist you with a fleet evaluation, design assistance and answer any technical questions you have. We invite your calls.

MOHAWK LIFTS

Mohawk Lifts, LLC.
 P.O. Box 110

AVAILABLE UNDER DISCOUNTED GOVERNMENT
 CONTRACT IN ALL 50 STATES



DISTRIBUTED BY:

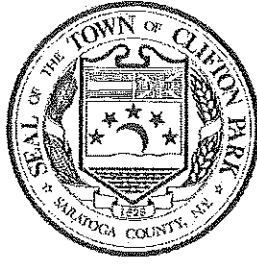

RESOLUTION

#13

PHILIP C. BARRETT
Supervisor

AGATHA REID
Councilwoman

ZABED MANIR
Councilman

NANCY R. BELLAMY
Councilwoman

MARIO L. FANTINI
Councilman

Resolution No. _____ of 2026, a resolution awarding the contract to supply dumpsters and provide dumpster service at fourteen (14) Town locations to County Waste & Recycling Service.

Introduced by _____, who moved its adoption, seconded by _____.

WHEREAS, Daniel Clemens, Director of Buildings, Parks and Recreation, solicited bids for dumpster supply and dumping services at fourteen (14) locations throughout Town, for two (2) years with a possible one (1) year extension, and

WHEREAS, sealed bids were opened on January 29, 2026, and

WHEREAS, County Waste and Recycling Service, Inc. submitted the lowest responsive bid per unit and total amount; now, therefore, be it

RESOLVED that the bid of County Waste and Recycling Service, Inc for dumpster supply and dumpster servicing at fourteen (14) Town locations is accepted, with the required transfers as detailed in the attached Schedule B; and be it further

RESOLVED that the Supervisor is authorized to sign a two (2) year agreement, with a possible one (1) year extension, with County Waste and Recycling, Inc., for the Town dumpster service.

Cynthia Zlogar

From: Town of Clifton Park Official Website <info@cliftonpark.org>
Sent: Friday, February 6, 2026 12:57 PM
To: Cynthia Zlogar; Phil Barrett; Jean Spiegel; Mark Heggen; Darlene Allen; Zabed Manir; Agatha Reid; John Scavo; Christine Pagnello; Walter Smead; Kelly Miller; Nancy Bellamy; Mario Fantini; Kevin Dailey; Caitlin Fantini
Subject: New Resolution Request #2567

A new resolution request has been submitted. The details of this resolution request are included below.

Department: Buildings & Grounds

Your Name: Daniel Clemens

Your Email: dclemens@cliftonpark.org

Sponsor: P. Barrett

Agenda Session Date: 02/24/2026 ✓

Board Meeting Date: 02/24/2026 ✓

Alternate Date: 02/24/2026

Budget Number: see schedule A

Budget Description: see schedule A

Amount: see schedule A

Brief Description: accept the bid from County Waste & Recycling Service, Inc. for dumpster service at 14 locations throughout town.

Add Supporting Docs:

[52ac86cb97ba1dcc_dumpster_service_res_packet_2.5.26.pdf](#)

[37d324fff75d57b4_2026_dumpster_service_Schedule_A.pdf](#)

Additional Comments/Details: requesting same day town board meeting - current contract expires February 28, 2026

Agree to Terms: Agree

[unsubscribe](#)

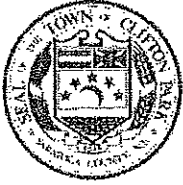

Town of Clifton Park Buildings & Grounds

One Town Hall Plaza • Clifton Park, New York 12065 • (518) 371-6651 Ext. 251 • Fax: (518) 371-1136

The Town of Clifton Park, through the Buildings & Grounds Department, seeks sealed bids from qualified entities for the supply of dumpsters and weekly service located in Clifton Park, NY, 12065.

Scope of work is as follows but not limited to:

- Supply varying sizes and types of dumpsters/containers at approximately 14 locations throughout town. Exact locations and dumpster sizes to be determined upon award.
- Provide weekly disposal service for dumpsters/containers.
- The term of the agreement will be two (2) years with the option to extend one (1) year upon the mutual agreement between the Town and contractor.

Specifications are available in the Town Clerk's Office, One Town Hall Plaza, Clifton Park, NY 12065 or by emailing Town Clerk Caitlin Fantini at cfantini@cliftonpark.org

Please use attached bid form

Sealed bids must be received at the Town Clerk's Office at One Town Hall Plaza, Clifton Park, NY, 12065, by 2:15 PM on January 29, 2026, at which time bids will be opened. Please identify your bid as "Dumpster Service".

The Town requires proof of Liability Insurance with One Million Dollars naming the Town as an additional insured, as well as appropriate Workers Compensation Insurance and automobile insurance.

Prevailing wage rate as described by New York State must be paid. The Town of Clifton Park reserves the right to reject any and all quotes.

The Town of Clifton Park reserves the right to require a performance bond of 5% of the bid price.

For information contact Dan Clemens, Director of Buildings, Parks, and Recreation at dclemens@cliftonpark.org 518-371-6651 ext. 248.

Supply of Dumpsters and Weekly Service BID Results 1/29/2026 @ 2:15pm

COMPANY NAME	Bid Amount
County Waste	4 yard \$94.00 per month 6 yard \$141.00 per month 96 gallon \$21.75 per month
Casella	4 yard \$130.00 per month year 1 MSW 4 yard \$136.50 per month year 2 MSW 4 yard \$100.00 per month year 1 Recycling 4 yard \$105.00 per month year 2 Recycling 6 yard \$195.00 per month year 1 MSW 6 yard \$204.75 per month year 2 MSW 96 gallon \$20.00 per month year 1 Recycling 96 gallon \$22.00 per month year 2 Recycling



Town of Clifton Park

Buildings & Grounds

One Town Hall Plaza • Clifton Park, New York 12065 • (518) 371-6651 Ext. 251 • Fax: (518) 371-1136

BID FORM

Date: 1/29/26

Company Name: County Waste & Recycling Service, Inc.

Bid Name: Dumpster Service

4-yard dumpster, cost per month: \$ 94.⁰⁰

6-yard dumpster, cost per month: \$ 141.⁰⁰

96-gallon container, cost per month: \$ 21.75

Name/Title: Chris Harrison, District Manager

Signature: Chris Harrison

2026 Dumpster Service

Schedule A

Location	Account	Waste Service	Recycling Service	Monthly Cost
Public Safety Building	A-1621-13	(1) 6-yard	(1) 4-yard	\$ 235.00
Senior Center	A-1624-13	(1) 4-yard	(1) 96 gal	\$ 115.75
Locust Ln	A-1625-13	(1) 4-yard		\$ 94.00
Arena	A-7112-13	(1) 6-yard		\$ 141.00
Town Hall B&G	A-1620-13 A-7110-13	(1) 6-yard		\$70.50 \$70.50
Burning Bush	A-1626-13	(1) 6-yard		\$ 141.00
Sewer	G7-8111-13	(1) 4-yard		\$ 94.00
Highway	A-5132-13	(1) 6-yard		\$ 141.00
Seasonal (April 1 - November 1)				
Collins Park	A-7113-13	(1) 4-yard		\$ 94.00
Softball	A-7112-13-40	(1) 4-yard		\$ 94.00
Baseball	A-7112-13-30	(1) 4-yard		\$ 94.00
Soccer	A-7112-13-10	(1) 4-yard		\$ 94.00
Barney Pool	A-7150-13	(1) 4-yard		\$ 94.00
Golf Course	A-7190-13	(1) 4-yard		\$ 94.00

Schedule B

Town of Clifton Park
Budget Adjustment for Refuse Removal

Location	Amount Needed	From A/C Number	To A/C Number
Town Hall	\$ 985.00	A-01620-00024	A-01620-00013
Public Safety Building	\$ 1,180.00	A-01621-00024	A-01621-00013
Clifton Park Senior Center	\$ 478.00	A-01624-00024	A-01624-00013
Locust Lane Clubhouse	\$ 90.00	A-01625-00024	A-01625-00013
Burning Bush Clubhouse	\$ 560.00	A-01626-00024	A-01626-00013
Highway Department	\$ 560.00	A-05132-00024	A-05132-00013
Building & Grounds	\$ 985.00	A-07110-00024	A-07110-00013
Clifton Park Sewer District #1	\$ 260.00	G7-08111-00024	G7-08111-00013
Clifton Common	\$ 664.00	A-07112-00024	A-07112-00013
Collins Park	\$ 148.00	A-07113-00024	A-07113-00013
Barney Road Pool	\$ 58.00	A-07150-00045	A-07150-00013
Barney Road Golf Course	\$ 1,128.00	A-07190-00024	A-07190-00013



CERTIFICATE OF LIABILITY INSURANCE

DATE (MM/DD/YYYY)
1/26/2026

THIS CERTIFICATE IS ISSUED AS A MATTER OF INFORMATION ONLY AND CONFERS NO RIGHTS UPON THE CERTIFICATE HOLDER. THIS CERTIFICATE DOES NOT AFFIRMATIVELY OR NEGATIVELY AMEND, EXTEND OR ALTER THE COVERAGE AFFORDED BY THE POLICIES BELOW. THIS CERTIFICATE OF INSURANCE DOES NOT CONSTITUTE A CONTRACT BETWEEN THE ISSUING INSURER(S), AUTHORIZED REPRESENTATIVE OR PRODUCER, AND THE CERTIFICATE HOLDER.

IMPORTANT: If the certificate holder is an ADDITIONAL INSURED, the policy(ies) must have ADDITIONAL INSURED provisions or be endorsed. If SUBROGATION IS WAIVED, subject to the terms and conditions of the policy, certain policies may require an endorsement. A statement on this certificate does not confer rights to the certificate holder in lieu of such endorsement(s).

PRODUCER NFP Prop & Casualty Serv Inc. 3620 American River Drive Suite 125 Sacramento CA 95864	CONTACT NAME: PHONE (A/C, No, Ext): FAX (A/C, No): E-MAIL: ADDRESS: wcnuscoirequest@nfp.com	
	INSURER(S) AFFORDING COVERAGE	
INSURED County Waste and Recycling Service, Inc. 3 Waterway Square Place, Suite #110 The Woodlands, TX 77386	INSURER A: ACE American Insurance Company NAIC # 22667	
	INSURER B: ACE Property & Casualty Insurance Company 20699	
	INSURER C: Ironshore Specialty Insurance Company 25445	
	INSURER D: Chubb Indemnity Insurance Company 12777	
	INSURER E:	
	INSURER F:	

COVERAGES **CERTIFICATE NUMBER: 2124643616** **REVISION NUMBER:**

THIS IS TO CERTIFY THAT THE POLICIES OF INSURANCE LISTED BELOW HAVE BEEN ISSUED TO THE INSURED NAMED ABOVE FOR THE POLICY PERIOD INDICATED. NOTWITHSTANDING ANY REQUIREMENT, TERM OR CONDITION OF ANY CONTRACT OR OTHER DOCUMENT WITH RESPECT TO WHICH THIS CERTIFICATE MAY BE ISSUED OR MAY PERTAIN, THE INSURANCE AFFORDED BY THE POLICIES DESCRIBED HEREIN IS SUBJECT TO ALL THE TERMS, EXCLUSIONS AND CONDITIONS OF SUCH POLICIES. LIMITS SHOWN MAY HAVE BEEN REDUCED BY PAID CLAIMS.

INSR LTR	TYPE OF INSURANCE	ADDL INSD	SUBR WVD	POLICY NUMBER	POLICY EFF (MM/DD/YYYY)	POLICY EXP (MM/DD/YYYY)	LIMITS
A	<input checked="" type="checkbox"/> COMMERCIAL GENERAL LIABILITY <input type="checkbox"/> CLAIMS-MADE <input checked="" type="checkbox"/> OCCUR GEN'L AGGREGATE LIMIT APPLIES PER: <input checked="" type="checkbox"/> POLICY <input type="checkbox"/> PRO-JECT <input type="checkbox"/> LOC OTHER:		Y	HDO G49353066	8/1/2026	8/1/2026	EACH OCCURRENCE \$2,000,000 DAMAGE TO RENTED PREMISES (Ea occurrence) \$1,000,000 MED EXP (Any one person) \$10,000 PERSONAL & ADV INJURY \$2,000,000 GENERAL AGGREGATE \$6,000,000 PRODUCTS - COMP/OP AGG \$4,000,000 \$
A	AUTOMOBILE LIABILITY <input checked="" type="checkbox"/> ANY AUTO <input type="checkbox"/> OWNED AUTOS ONLY <input type="checkbox"/> SCHEDULED AUTOS NON-OWNED AUTOS ONLY <input type="checkbox"/> HIRED AUTOS ONLY			ISAH10755517	8/1/2025	8/1/2026	COMBINED SINGLE LIMIT (Ea accident) \$10,000,000 BODILY INJURY (Per person) \$ BODILY INJURY (Per accident) \$ PROPERTY DAMAGE (Per accident) \$ \$
B	<input checked="" type="checkbox"/> UMBRELLA LIAB <input checked="" type="checkbox"/> OCCUR <input type="checkbox"/> EXCESS LIAB <input type="checkbox"/> CLAIMS-MADE <input type="checkbox"/> DED <input checked="" type="checkbox"/> RETENTION \$ Per Policy			XEU G27614620 011	8/1/2025	8/1/2026	EACH OCCURRENCE \$5,000,000 AGGREGATE \$5,000,000 Prod/Comp Opp Agg \$5,000,000
D	WORKERS COMPENSATION AND EMPLOYERS' LIABILITY ANY PROPRIETOR/PARTNER/EXECUTIVE OFFICER/MEMBER EXCLUDED? (Mandatory in NH) If yes, describe under DESCRIPTION OF OPERATIONS below		Y/N N	WLR C72796573	8/1/2025	8/1/2026	<input checked="" type="checkbox"/> PER STATUTE <input type="checkbox"/> OTH-ER E.L. EACH ACCIDENT \$1,500,000 E.L. DISEASE - EA EMPLOYEE \$1,500,000 E.L. DISEASE - POLICY LIMIT \$1,500,000
C	Pollution Liability			ISPILLSB650R003	2/13/2024	2/13/2026	Per Occurrence \$5,000,000 Aggregate \$5,000,000

DESCRIPTION OF OPERATIONS / LOCATIONS / VEHICLES (ACORD 101, Additional Remarks Schedule, may be attached if more space is required)

Waiver of Subrogation applies to the General Liability if required by written contract.

CERTIFICATE HOLDER

CANCELLATION

Town of Clifton Park One Town Hall Plaza Clifton Park, NY 12065	SHOULD ANY OF THE ABOVE DESCRIBED POLICIES BE CANCELLED BEFORE THE EXPIRATION DATE THEREOF, NOTICE WILL BE DELIVERED IN ACCORDANCE WITH THE POLICY PROVISIONS. AUTHORIZED REPRESENTATIVE
---	---

© 1988-2015 ACORD CORPORATION. All rights reserved.

POLICY NUMBER: HDO G49353066

1
Endorsement Number: 172

COMMERCIAL GENERAL LIABILITY
CG 24 04 12 19

THIS ENDORSEMENT CHANGES THE POLICY. PLEASE READ IT CAREFULLY.

**WAIVER OF TRANSFER OF RIGHTS OF RECOVERY
AGAINST OTHERS TO US (WAIVER OF SUBROGATION)**

This endorsement modifies insurance provided under the following:

COMMERCIAL GENERAL LIABILITY COVERAGE PART
ELECTRONIC DATA LIABILITY COVERAGE PART
LIQUOR LIABILITY COVERAGE PART
POLLUTION LIABILITY COVERAGE PART DESIGNATED SITES
POLLUTION LIABILITY LIMITED COVERAGE PART DESIGNATED SITES
PRODUCTS/COMPLETED OPERATIONS LIABILITY COVERAGE PART
RAILROAD PROTECTIVE LIABILITY COVERAGE PART
UNDERGROUND STORAGE TANK POLICY DESIGNATED TANKS

SCHEDULE

Name Of Person(s) Or Organization(s): Any person or organization against whom you have agreed to waive your right of recovery in a written contract, provided such contract was executed prior to the date of loss.
--

Information required to complete this Schedule, if not shown above, will be shown in the Declarations.
--

The following is added to Paragraph 8. **Transfer Of Rights Of Recovery Against Others To Us** of Section IV – Conditions:

We waive any right of recovery against the person(s) or organization(s) shown in the Schedule above because of payments we make under this Coverage Part. Such waiver by us applies only to the extent that the insured has waived its right of recovery against such person(s) or organization(s) prior to loss. This endorsement applies only to the person(s) or organization(s) shown in the Schedule above.



Town of Clifton Park

Buildings & Grounds

One Town Hall Plaza • Clifton Park, New York 12065 • (518)371-6651 Ext. 251 • Fax: (518)371-1136

BID FORM

Date: January 29, 2026

Company Name: Casella Waste Management of NY, Inc.

Bid Name: Dumpster Service

4-yard dumpster, cost per month: \$ 130.00 year 1 MSW; \$136.50 year 2 MSW
\$ 100.00 year 1 Recycling ; \$105 year 2 Recycling

6-yard dumpster, cost per month: \$ 195.00 year 1 MSW; \$204.75 year 2 MSW

96-gallon container, cost per month: \$ 20 year 1 Recycling; \$21 year 2 Recycling

Name/Title: Martin Golubski Market Area Manager & Duly Authorized Agent

Signature: 

2026 Dumpster Service

Schedule A

Year 1

Location	Account	Waste Service	Recycling Service	Monthly Cost
Public Safety Building	A-1621-13	(1) 6-yard	(1) 4-yard	295
Senior Center	A-1624-13	(1) 4-yard	(1) 96 gal	150
Locust Ln	A-1625-13	(1) 4-yard		130
Arena	A-7112-13	(1) 6-yard		195
Town Hall B&G	A-1620-13 A-7110-13	(1) 6-yard		195
Burning Bush	A-1626-13	(1) 6-yard		195
Sewer	G7-8111-13	(1) 4-yard		130
Highway	A-5132-13	(1) 6-yard		195
Seasonal (April 1 - November 1)				
Collins Park	A-7113-13	(1) 4-yard		130
Softball	A-7112-13-40	(1) 4-yard		130
Baseball	A-7112-13-30	(1) 4-yard		130
Soccer	A-7112-13-10	(1) 4-yard		130
Barney Pool	A-7150-13	(1) 4-yard		130
Golf Course	A-7190-13	(1) 4-yard		130

CERTIFICATE OF AUTHORITY
Casella Waste Management of N.Y., Inc.

At a duly authorized meeting of the Board of Directors of Casella Waste Management of N.Y., Inc., it was voted that Edmond R. Coletta, President, and/or Shelley E. Sayward, Vice President & Secretary, and/or Martin Golubski Jr., Market Area Manager, are each authorized to independently execute any and all bid documents related to the Town of Clifton Park, New York's Request for Bids for "Solid Waste Disposal & Dumpster Service" as well as any and all contract related documents in the event of an award of the foregoing to Casella Waste Management N.Y., Inc.

It was also voted that Edmond R. Coletta, President, and/or Shelley E. Sayward, Vice President & Secretary, are each authorized to execute any and all bond related documents in connection with the Town of Clifton Park's Bid Proposal, including but not limited to bid bonds and performance bonds.

In the name of and on behalf of Casella Waste Management N.Y., Inc.; and affix its corporate seal hereto; and such execution of any contract obligation in this company's name and on its behalf; said obligation to be valid and binding upon Casella Waste Management N.Y., Inc.

A True Copy Attested,

Company Name: Casella Waste Management N.Y., Inc.
Address: 411 Route 146
Clifton Park, NY 12065
Name & Title of Signatory: Shelley E. Sayward, Vice President & Secretary
Date: January 29, 2026

I hereby certify that I am the Secretary of Casella Waste Management N.Y., Inc., and the above vote has not been amended or rescinded and remains in full force and effect as of the date of this certificate.

Signature:

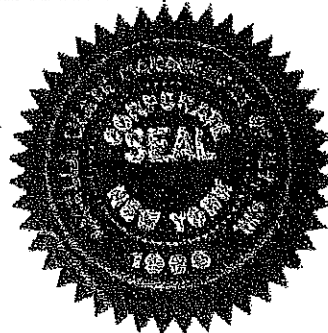



Workers' Compensation Board

CERTIFICATE OF NYS WORKERS' COMPENSATION INSURANCE COVERAGE

<p>1a. Legal Name & Address of Insured (use street address only)</p> <p>Casella Waste Management of NY, Inc. 411 Roue 146 Clifton Park, NY 12065</p> <p><i>Work Location of Insured (Only required if coverage is specifically limited to certain locations in New York State, i.e., a Wrap-Up Policy)</i></p>	<p>1b. Business Telephone Number of Insured 518-491-5292</p> <p>1c. NYS Unemployment Insurance Employer Registration Number of Insured 50-75293</p> <p>1d. Federal Employer Identification Number of Insured or Social Security Number 01-0329311</p>
<p>2. Name and Address of the Entity Requesting Proof of Coverage (Entity Being Listed as the Certificate Holder)</p> <p>Town of Clifton Park Buildings & Grounds One Town Hall Plaza Clifton Park, NY 12065</p>	<p>3a. Name of Insurance Carrier Old Republic Insurance Company</p> <p>3b. Policy Number of entity listed in box "1a" MWC 311994 26</p> <p>3c. Policy effective period 01/01/2026 to 01/01/2027</p> <p>3d. The Proprietor, Partners or Executive Officers are <input checked="" type="checkbox"/> included. (Only check box if all partners/officers included) <input type="checkbox"/> all excluded or certain partners/officers excluded.</p>

This certifies that the insurance carrier indicated above in box "3" insures the business referenced above in box "1a" for workers' compensation under the New York State Workers' Compensation Law. (To use this form, New York (NY) must be listed under **Item 3A** on the INFORMATION PAGE of the workers' compensation insurance policy). The Insurance Carrier or its licensed agent will send this Certificate of Insurance to the entity listed above as the certificate holder in box "2".

Will the carrier notify the certificate holder within 10 days of a policy being cancelled for non-payment of premium or within 30 days if cancelled for any other reason or if the insured is otherwise eliminated from the coverage indicated on this certificate prior to the end of the policy effective period? YES NO

This certificate is issued as a matter of information only and confers no rights upon the certificate holder. This certificate does not amend, extend or alter the coverage afforded by the policy listed, nor does it confer any rights or responsibilities beyond those contained in the referenced policy.

This certificate may be used as evidence of a Workers' Compensation contract of insurance only while the underlying policy is in effect.

Please Note: Upon cancellation of the workers' compensation policy indicated on this form, if the business continues to be named on a permit, license or contract issued by a certificate holder, the business must provide that certificate holder with a new Certificate of Workers' Compensation Coverage or other authorized proof that the business is complying with the mandatory coverage requirements of the New York State Workers' Compensation Law.

Under penalty of perjury, I certify that I am an authorized representative or licensed agent of the insurance carrier referenced above and that the named insured has the coverage as depicted on this form.

Approved by: Audrey Macie
(Print name of authorized representative or licensed agent of Insurance carrier)

Approved by: Audrey L Macie 01/27/2026
(Signature) (Date)

Title: Licensed Agent for Old Republic Insurance Company

Telephone Number of authorized representative or licensed agent of insurance carrier: (802) 223-7735

Please Note: Only insurance carriers and their licensed agents are authorized to issue Form C-105.2. Insurance brokers are NOT authorized to issue it.

Workers' Compensation Law

Section 57. Restriction on issue of permits and the entering into contracts unless compensation is secured.

1. The head of a state or municipal department, board, commission or office authorized or required by law to issue any permit for or in connection with any work involving the employment of employees in a hazardous employment defined by this chapter, and notwithstanding any general or special statute requiring or authorizing the issue of such permits, shall not issue such permit unless proof duly subscribed by an insurance carrier is produced in a form satisfactory to the chair, that compensation for all employees has been secured as provided by this chapter. Nothing herein, however, shall be construed as creating any liability on the part of such state or municipal department, board, commission or office to pay any compensation to any such employee if so employed.
2. The head of a state or municipal department, board, commission or office authorized or required by law to enter into any contract for or in connection with any work involving the employment of employees in a hazardous employment defined by this chapter, notwithstanding any general or special statute requiring or authorizing any such contract, shall not enter into any such contract unless proof duly subscribed by an insurance carrier is produced in a form satisfactory to the chair, that compensation for all employees has been secured as provided by this chapter.



RESOLUTION

#14

PHILIP C. BARRETT
Supervisor

AGATHA REID
Councilwoman

ZABED MANIR
Councilman

NANCY R. BELLAMY
Councilwoman

MARIO L. FANTINI
Councilman

Resolution No. _____ of 2026, a resolution awarding the contract for Transfer Station Solid Waste Disposal.

Introduced by _____, who moved its adoption, seconded by _____.

WHEREAS, Daniel Clemens, Director of Buildings, Parks & Recreation, requested that bids be solicited for the renewal of a two (2) year agreement, with a possible one (1) year extension, for Solid Waste Disposal for the Transfer Station, and

WHEREAS, bids were opened on January 29, 2026; and

WHEREAS, two bids were received and after careful consideration of each, Mr. Clemens recommends the acceptance of the bid from Casella Waste Management, as explained in his correspondence dated February 5, 2026, attached; now, therefore, be it

RESOLVED that the bid of Casella Waste Management for residential waste hauling at the Town of Clifton Park Transfer Station is accepted; and be it further

RESOLVED, that the Supervisor is authorized to sign a two (2) year agreement, with a possible one (1) year extension, with Casella Waste Management for the Transfer Station Solid Waste Disposal.

Cynthia Zlogar

From: Town of Clifton Park Official Website <info@cliftonpark.org>
Sent: Friday, February 6, 2026 1:05 PM
To: Cynthia Zlogar; Phil Barrett; Jean Spiegel; Mark Heggen; Darlene Allen; Zabed Manir; Agatha Reid; John Scavo; Christine Pagniello; Walter Smead; Kelly Miller; Nancy Bellamy; Mario Fantini; Kevin Dailey; Caitlin Fantini
Subject: New Resolution Request #2568

A new resolution request has been submitted. The details of this resolution request are included below.

Department: Buildings & Grounds

Your Name: Daniel Clemens

Your Email: dclemens@cliftonpark.org

Sponsor: P. Barrett

Agenda Session Date: 02/24/2026 ✓

Board Meeting Date: 02/24/2026 ✓

Alternate Date: 02/24/2026

Budget Number: A-8160-013

Budget Description: General Fund - Solid Waste Management - Refuse Removal

Amount: \$117.00 per ton plus \$220 per haul year (1) \$125.19 per ton plus \$210 per haul year 2

Brief Description: accept the bid from Casella Waste Management of NY, Inc. for a 2-year agreement for solid waste disposal at the transfer station.

Add Supporting Docs:

[c2cf567f8484bf0e_solid_waste_bid_-_Casella_memo_2.5.26.docx](#)

[63f4f614d72222a2_solid_waste_disposal_res_packet_2.5.26.pdf](#)

Additional Comments/Details: request same day town board meeting. Current contract expires February 28, 2026

Agree to Terms: Agree

[unsubscribe](#)



Town of Clifton Park

Buildings & Grounds

One Town Hall Plaza • Clifton Park, New York 12065 • (518) 371-6651 Ext. 251 • Fax: (518) 371-1136

The Town of Clifton Park, through the Buildings & Grounds Department, seeks sealed bids from qualified entities for solid waste disposal located in Clifton Park, NY, 12065.

INFORMATION FOR BIDDERS

The Town of Clifton Park owns and operates a solid waste transfer station on Vischer Ferry Road for use by residents of the Town. According to 2025 records, the following quantities of solid waste were generated at this facility:

2024: 1623.75 tons MSW	940.03 tons CDD
2025: 1622.22 tons MSW	1235.08 tons CDD

Bidders are advised that quantities will vary, and payment will be based on actual tonnage certified at the receiving facility.

The Town is seeking proposals from qualified contractors to provide the following services:

A) Contractor hauling to an approved solid waste facility

The bidder shall be responsible for both hauling solid waste from the transfer station, and for disposal fees at an approved NYSDEC solid waste facility. The bidder shall provide all equipment, including roll-off boxes, tractor trailers, drivers, and other equipment and labor for the complete hauling and disposal, for the duration of the contract.

B) The bidder should provide all permits and governmental approvals demonstrating capacity to perform contract as bid.

C) The bidder may be required to disconnect and bib a compactor box before hauling and/or reconnect the box and put the empty compactor box back into service on occasion.

SPECIAL NOTES

- The terms of the contract will be for a period of two (2) years starting at the date of contract execution by both parties. The contract can be extended for a maximum of one (1) year with mutual agreement by both parties.
- The Town reserves the right to reject any and all bids
- Bidders are encouraged to visit the Town's Transfer Station facility to view the operation and compaction equipment. Visits can be arranged by contacting Daniel Clemens at dclemens@cliftonpark.org or (518) 371-6651.
- The Town agrees to pay the selected bidder monthly for the quantities of solid waste brought to a NYSDEC solid waste facility based on certified weight measurements at the facilities scales.
- The successful bidder shall commit to pick up all solid waste at the Town facility on 24-hour notice, per telephone notification, Monday through Saturday throughout the contract period.

Specifications are available in the Town Clerk's Office, One Town Hall Plaza, Clifton Park, NY 12065 or by emailing Town Clerk Caitlin Fantini at cfantini@cliftonpark.org

Please use attached bid form

Sealed bids must be received at the Town Clerk's Office at One Town Hall Plaza, Clifton Park, NY, 12065, by 2:00 PM on Thursday January 29, 2026, at which time bids will be opened. Please identify your bid as "Solid Waste Disposal".

The Town requires proof of Liability Insurance with One Million Dollars naming the Town as an additional insured, as well as appropriate Workers Compensation Insurance and automobile insurance.

Prevailing wage rate as described by New York State must be paid.

The Town of Clifton Park reserves the right to require a performance bond of 5% of the bid price.

For information contact Dan Clemens, Director of Buildings, Parks, and Recreation at dclemens@cliftonpark.org 518-371-6651 ext. 248.

Solid Waste Disposal BID Results 1/29/2026 @ 2pm

COMPANY NAME	Bid Amount
Country Waste	\$117.25 per Ton MSW \$117.25 per Ton CDD \$218.50 per Haul
Casella	\$117.00 per Ton MSW Year 1 \$125.19 per Ton MSW Year 2 \$117.00 per Ton Recycling Year 1 \$125.19 per Ton Recycling Year 2 \$200 per Haul Year 1 \$210 per Haul Year 2



Town of Clifton Park

Buildings & Grounds

One Town Hall Plaza • Clifton Park, New York 12065 • (518) 371-6651 Ext. 251 • Fax: (518) 371-1136

TO: Supervisor Barrett and Town Board members

CC: Kevin Dailey, Mark Heggen

FROM: Daniel J. Clemens, Director of Buildings, Parks, and Recreation

DATE: February 5, 2026

SUBJECT: Solid Waste Disposal bid results

Sealed bids for solid waste disposal were opened on January 29, 2026, at 2pm. We had two bids, County Waste and Casella. The bids were very close, and Casella submitted one price for year one and a higher price for year 2 of the advertised two-year agreement. I spent quite a bit of time with Mark Heggen analyzing the bids and trying to calculate who is lower. Not knowing how many tons will be hauled and how many hauls it will take added to the challenge. What we did was use 2025 tonnage and hauls based on our invoices and calculated the total amount for each bidder for the 2-years. Casella is lower for 2026 hauling but slightly higher in 2027. County Waste 2-year total is lower by less than 1 percent, .6853274% to be exact. Based on my experience working with both companies I prefer to stay with Casella for this service. Casella has always had all the boxes required and responds almost instantly when called for a pick-up. We never have full boxes of garbage sitting there. They know to come every Monday and there will be a couple of full compactor boxes and 2-3 CDD boxes. Customer service is outstanding; reps always answer the phone. Billing is spot on and the accounting department is also great to work with. I cannot say the same for County Waste, who hauls for the recycling center that the Town manages. They rarely have enough boxes to cover the five stations. When we call them for pick-up it is days until they come leaving us with full boxes on a Friday afternoon. When this happens, it is not possible to keep all the buildings open and causes major congestion and inconvenience for residents. Based on policy 4 of the Town's procurement policy I request you accept the bid from Casella for solid waste disposal at the transfer station.

2026 County Waste/Casella Comparison
Based on 2025 Hauls & Tons

	2026 County Waste	2026 Casella
January		
Hauls	40 \$ 8,740.00	\$ 8,000.00
Tons	199.89 \$ 23,437.10	\$ 23,387.13
2026 Totals	\$ 32,177.10	\$ 31,387.13

	2026 County Waste	2026 Casella
February		
Hauls	28 \$ 6,118.00	\$ 5,600.00
Tons	151.81 \$ 17,799.72	\$ 17,761.77
2026 Totals	\$ 23,917.72	\$ 23,361.77

	2026 County Waste	2026 Casella
March		
Hauls	49 \$ 10,706.50	\$ 9,800.00
Tons	219.63 \$ 25,751.62	\$ 25,696.71
2026 Totals	\$ 36,458.12	\$ 35,496.71

	2026 County Waste	2026 Casella
April		
Hauls	43 \$ 9,395.50	\$ 8,600.00
Tons	208 \$ 24,388.00	\$ 24,336.00
2026 Totals	\$ 33,783.50	\$ 32,936.00

	2026 County Waste	2026 Casella
May		
Hauls	32 \$ 6,992.00	\$ 6,400.00
Tons	259.16 \$ 30,386.51	\$ 30,321.72
2026 Totals	\$ 37,378.51	\$ 36,721.72

	2026 County Waste	2026 Casella
June		
Hauls	61 \$ 13,328.50	\$ 12,200.00
Tons	309.21 \$ 36,254.87	\$ 36,177.57
2026 Totals	\$ 49,583.37	\$ 48,377.57

	2026 County Waste	2026 Casella
July		
Hauls	59 \$ 12,891.50	\$ 11,800.00
Tons	270.53 \$ 31,719.64	\$ 31,652.01
2026 Totals	\$ 44,611.14	\$ 43,452.01

	2026 County Waste	2026 Casella
August		
Hauls	62 \$ 13,547.00	\$ 12,400.00
Tons	276.86 \$ 32,461.84	\$ 32,392.62
2026 Totals	\$ 46,008.84	\$ 44,792.62

	2026 County Waste	2026 Casella
Sept		
Hauls	51 \$ 11,143.50	\$ 10,200.00
Tons	229.23 \$ 26,877.22	\$ 26,819.91
2026 Totals	\$ 38,020.72	\$ 37,019.91

	2026 County Waste	2026 Casella
Oct		
Hauls	65 \$ 14,202.50	\$ 13,000.00
Tons	300.65 \$ 35,251.21	\$ 35,176.05
2026 Totals	\$ 49,453.71	\$ 48,176.05

	2026 County Waste	2026 Casella
Nov		
Hauls	44 \$ 9,614.00	\$ 8,800.00
Tons	212.67 \$ 24,935.56	\$ 24,882.39
2026 Totals	\$ 34,549.56	\$ 33,682.39

	2026 County Waste	2026 Casella
Dec		
Hauls	44 \$ 9,614.00	\$ 8,800.00
Tons	219.66 \$ 25,755.14	\$ 25,700.22
2026 Totals	\$ 35,369.14	\$ 34,500.22

Hauls: 570 \$461,311.43
\$449,904.10

2027 County Waste/Casella Comparison
Based on 2025 Hauls & Tons

	2027 County Waste	2027 Casella
January		
Hauls	40 \$ 8,740.00	\$ 8,400.00
Tons	199.89 \$ 23,437.10	\$ 25,024.23
2027 Totals	\$ 32,177.10	\$ 33,424.23

	2027 County Waste	2027 Casella
February		
Hauls	28 \$ 6,118.00	\$ 5,880.00
Tons	151.81 \$ 17,799.72	\$ 19,005.09
2027 Totals	\$ 23,917.72	\$ 24,885.09

	2027 County Waste	2027 Casella
March		
Hauls	49 \$ 10,706.50	\$ 10,290.00
Tons	219.63 \$ 25,751.62	\$ 27,495.48
2027 Totals	\$ 36,458.12	\$ 37,785.48

	2027 County Waste	2027 Casella
April		
Hauls	43 \$ 9,395.50	\$ 9,030.00
Tons	208 \$ 24,388.00	\$ 26,039.52
2027 Totals	\$ 33,783.50	\$ 35,069.52

	2027 County Waste	2027 Casella
May		
Hauls	32 \$ 6,992.00	\$ 6,720.00
Tons	259.16 \$ 30,386.51	\$ 32,444.24
2027 Totals	\$ 37,378.51	\$ 39,164.24

	2027 County Waste	2027 Casella
June		
Hauls	61 \$ 13,328.50	\$ 12,810.00
Tons	309.21 \$ 36,254.87	\$ 38,710.00
2027 Totals	\$ 49,583.37	\$ 51,520.00

	2027 County Waste	2027 Casella
July		
Hauls	59 \$ 12,891.50	\$ 12,390.00
Tons	270.53 \$ 31,719.64	\$ 33,867.65
2027 Totals	\$ 44,611.14	\$ 46,257.65

	2027 County Waste	2027 Casella
August		
Hauls	62 \$ 13,547.00	\$ 13,020.00
Tons	276.86 \$ 32,461.84	\$ 34,660.10
2027 Totals	\$ 46,008.84	\$ 47,680.10

	2027 County Waste	2027 Casella
Sept		
Hauls	51 \$ 11,143.50	\$ 10,710.00
Tons	229.23 \$ 26,877.22	\$ 28,697.30
2027 Totals	\$ 38,020.72	\$ 39,407.30

	2027 County Waste	2027 Casella
Oct		
Hauls	65 \$ 14,202.50	\$ 13,650.00
Tons	300.65 \$ 35,251.21	\$ 37,638.37
2027 Totals	\$ 49,453.71	\$ 51,288.37

	2027 County Waste	2027 Casella
Nov		
Hauls	44 \$ 9,614.00	\$ 9,240.00
Tons	212.67 \$ 24,935.56	\$ 26,624.16
2027 Totals	\$ 34,549.56	\$ 35,864.16

	2027 County Waste	2027 Casella
Dec		
Hauls	44 \$ 9,614.00	\$ 9,240.00
Tons	219.66 \$ 25,755.14	\$ 27,499.24
2027 Totals	\$ 35,369.14	\$ 36,739.24

HAULS: 578 **# 461, 311.43** **\$ 477,085.38**

2 YEAR TOTAL - \$922,622.86 **\$ 920,989.48**

DIFFERENCE
\$ 6,360.62 **< 1%**
0.0532745



Town of Clifton Park

Buildings & Grounds

One Town Hall Plaza • Clifton Park, New York 12065 • (518) 371-6651 Ext. 251 • Fax: (518) 371-1136

BID FORM

Date: 1/29/26

Company Name: County Waste & Recycling Service, Inc.

Bid Name: Solid Waste Disposal

Cost of MSW per ton: \$ 117.25

Cost of CDD per ton: \$ 117.25

Cost per haul: \$ 218.50

Name/Title: Chris Harrison, District Manager

Signature: Chris Harrison



CERTIFICATE OF LIABILITY INSURANCE

DATE (MM/DD/YYYY)

1/26/2026

THIS CERTIFICATE IS ISSUED AS A MATTER OF INFORMATION ONLY AND CONFERS NO RIGHTS UPON THE CERTIFICATE HOLDER. THIS CERTIFICATE DOES NOT AFFIRMATIVELY OR NEGATIVELY AMEND, EXTEND OR ALTER THE COVERAGE AFFORDED BY THE POLICIES BELOW. THIS CERTIFICATE OF INSURANCE DOES NOT CONSTITUTE A CONTRACT BETWEEN THE ISSUING INSURER(S), AUTHORIZED REPRESENTATIVE OR PRODUCER, AND THE CERTIFICATE HOLDER.

IMPORTANT: If the certificate holder is an ADDITIONAL INSURED, the policy(ies) must have ADDITIONAL INSURED provisions or be endorsed. If SUBROGATION IS WAIVED, subject to the terms and conditions of the policy, certain policies may require an endorsement. A statement on this certificate does not confer rights to the certificate holder in lieu of such endorsement(s).

PRODUCER NFP Prop & Casualty Serv Inc. 3620 American River Drive Suite 125 Sacramento CA 95864	CONTACT NAME: PHONE (A/C No. Ext): _____ FAX (A/C No.): _____ E-MAIL ADDRESS: wcnuscoirequest@nfp.com		
	INSURER(S) AFFORDING COVERAGE		
INSURED County Waste and Recycling Service, Inc. 3 Waterway Square Place, Suite #110 The Woodlands, TX 77386	WASTCON-03	INSURER A: ACE American Insurance Company INSURER B: ACE Property & Casualty Insurance Company INSURER C: Ironshore Specialty Insurance Company INSURER D: Chubb Indemnity Insurance Company INSURER E: INSURER F:	NAIC # 22667 20699 25445 12777

COVERAGES

CERTIFICATE NUMBER: 2124643616

REVISION NUMBER:

THIS IS TO CERTIFY THAT THE POLICIES OF INSURANCE LISTED BELOW HAVE BEEN ISSUED TO THE INSURED NAMED ABOVE FOR THE POLICY PERIOD INDICATED. NOTWITHSTANDING ANY REQUIREMENT, TERM OR CONDITION OF ANY CONTRACT OR OTHER DOCUMENT WITH RESPECT TO WHICH THIS CERTIFICATE MAY BE ISSUED OR MAY PERTAIN, THE INSURANCE AFFORDED BY THE POLICIES DESCRIBED HEREIN IS SUBJECT TO ALL THE TERMS, EXCLUSIONS AND CONDITIONS OF SUCH POLICIES. LIMITS SHOWN MAY HAVE BEEN REDUCED BY PAID CLAIMS.

INSR LTR	TYPE OF INSURANCE	ADDL INSD	SUBR WVD	POLICY NUMBER	POLICY EFF (MM/DD/YYYY)	POLICY EXP (MM/DD/YYYY)	LIMITS	
A	<input checked="" type="checkbox"/> COMMERCIAL GENERAL LIABILITY <input type="checkbox"/> CLAIMS-MADE <input checked="" type="checkbox"/> OCCUR GEN'L AGGREGATE LIMIT APPLIES PER: <input checked="" type="checkbox"/> POLICY <input type="checkbox"/> PRO-JECT <input type="checkbox"/> LOC OTHER:		Y	HDO G49353066	8/1/2025	8/1/2026	EACH OCCURRENCE \$ \$2,000,000 DAMAGE TO RENTED PREMISES (Ea occurrence) \$ \$1,000,000 MED EXP (Any one person) \$ \$10,000 PERSONAL & ADV INJURY \$ \$2,000,000 GENERAL AGGREGATE \$ \$5,000,000 PRODUCTS - COMP/OP AGG \$ \$4,000,000 \$	
A	AUTOMOBILE LIABILITY <input checked="" type="checkbox"/> ANY AUTO <input type="checkbox"/> OWNED AUTOS ONLY <input type="checkbox"/> SCHEDULED AUTOS NON-OWNED AUTOS ONLY <input type="checkbox"/> HIRED AUTOS ONLY			ISAH10755517	8/1/2025	8/1/2026	COMBINED SINGLE LIMIT (Ea accident) \$ \$10,000,000 BODILY INJURY (Per person) \$ BODILY INJURY (Per accident) \$ PROPERTY DAMAGE (Per accident) \$ \$	
B	<input checked="" type="checkbox"/> UMBRELLA LIAB <input checked="" type="checkbox"/> OCCUR <input type="checkbox"/> EXCESS LIAB <input type="checkbox"/> CLAIMS-MADE <input type="checkbox"/> DED <input checked="" type="checkbox"/> RETENTION \$ Per Policy			XEU G27614620 011	8/1/2025	8/1/2026	EACH OCCURRENCE \$ \$5,000,000 AGGREGATE \$ \$5,000,000 Prod/Comp Opp Agg \$ \$5,000,000	
D	WORKERS COMPENSATION AND EMPLOYERS' LIABILITY ANY PROPRIETOR/PARTNER/EXECUTIVE OFFICER/MEMBER EXCLUDED? (Mandatory in NH) If yes, describe under DESCRIPTION OF OPERATIONS below		Y/N N	WLR C72796673	8/1/2025	8/1/2026	<input checked="" type="checkbox"/> PER STATUTE <input type="checkbox"/> OTHER EL, EACH ACCIDENT \$ \$1,500,000 EL, DISEASE - EA EMPLOYEE \$ \$1,500,000 EL, DISEASE - POLICY LIMIT \$ \$1,500,000	
C	Pollution Liability			ISPILLSB650R003	2/13/2024	2/13/2026	Per Occurrence \$5,000,000 Aggregate \$5,000,000	

DESCRIPTION OF OPERATIONS / LOCATIONS / VEHICLES (ACORD 101, Additional Remarks Schedule, may be attached if more space is required)

Waiver of Subrogation applies to the General Liability if required by written contract.

CERTIFICATE HOLDER**CANCELLATION**

Town of Clifton Park One Town Hall Plaza Clifton Park, NY 12065	SHOULD ANY OF THE ABOVE DESCRIBED POLICIES BE CANCELLED BEFORE THE EXPIRATION DATE THEREOF, NOTICE WILL BE DELIVERED IN ACCORDANCE WITH THE POLICY PROVISIONS. AUTHORIZED REPRESENTATIVE
---	---

© 1988-2015 ACORD CORPORATION. All rights reserved.

POLICY NUMBER: HDO G49353066

1
Endorsement Number: 172

COMMERCIAL GENERAL LIABILITY
CG 24 04 12 19

THIS ENDORSEMENT CHANGES THE POLICY. PLEASE READ IT CAREFULLY.

WAIVER OF TRANSFER OF RIGHTS OF RECOVERY AGAINST OTHERS TO US (WAIVER OF SUBROGATION)

This endorsement modifies insurance provided under the following:

COMMERCIAL GENERAL LIABILITY COVERAGE PART
ELECTRONIC DATA LIABILITY COVERAGE PART
LIQUOR LIABILITY COVERAGE PART
POLLUTION LIABILITY COVERAGE PART DESIGNATED SITES
POLLUTION LIABILITY LIMITED COVERAGE PART DESIGNATED SITES
PRODUCTS/COMPLETED OPERATIONS LIABILITY COVERAGE PART
RAILROAD PROTECTIVE LIABILITY COVERAGE PART
UNDERGROUND STORAGE TANK POLICY DESIGNATED TANKS

SCHEDULE

Name Of Person(s) Or Organization(s): Any person or organization against whom you have agreed to waive your right of recovery in a written contract, provided such contract was executed prior to the date of loss.

Information required to complete this Schedule, if not shown above, will be shown in the Declarations.

The following is added to Paragraph 8. **Transfer Of Rights Of Recovery Against Others To Us** of Section IV – Conditions:

We waive any right of recovery against the person(s) or organization(s) shown in the Schedule above because of payments we make under this Coverage Part. Such waiver by us applies only to the extent that the Insured has waived its right of recovery against such person(s) or organization(s) prior to loss. This endorsement applies only to the person(s) or organization(s) shown in the Schedule above.



Town of Clifton Park

Buildings & Grounds

One Town Hall Plaza • Clifton Park, New York 12065 • (518) 371-6651 Ext. 251 • Fax: (518) 371-1136

BID FORM

Date: January 29th, 2026

Company Name: Casella Waste Management of NY, Inc.

Bid Name: Solid Waste Disposal

Cost of MSW per ton: \$ 117.00 year 1 \$ 125.19 year 2

Cost of CDD per ton: \$ 117.00 year 1 \$ 125.19 year 2

Cost per haul: \$ 200.00 year 1 \$ 210.00 year 2

Name/Title: Martin Golubski Market Area Manager & Duly Authorized Agent

Signature: _____

CERTIFICATE OF AUTHORITY
Casella Waste Management of N.Y., Inc.

At a duly authorized meeting of the Board of Directors of Casella Waste Management of N.Y., Inc., it was voted that Edmond R. Coletta, President, and/or Shelley E. Sayward, Vice President & Secretary, and/or Martin Golubski Jr., Market Area Manager, are each authorized to independently execute any and all bid documents related to the Town of Clifton Park, New York's Request for Bids for "Solid Waste Disposal & Dumpster Service" as well as any and all contract related documents in the event of an award of the foregoing to Casella Waste Management N.Y., Inc.

It was also voted that Edmond R. Coletta, President, and/or Shelley E. Sayward, Vice President & Secretary, are each authorized to execute any and all bond related documents in connection with the Town of Clifton Park's Bid Proposal, including but not limited to bid bonds and performance bonds.

In the name of and on behalf of Casella Waste Management N.Y., Inc.; and affix its corporate seal hereto; and such execution of any contract obligation in this company's name and on its behalf; said obligation to be valid and binding upon Casella Waste Management N.Y., Inc.

A True Copy Attested,

Company Name: Casella Waste Management N.Y., Inc.
Address: 411 Route 146
Clifton Park, NY 12065
Name & Title of Signatory: Shelley E. Sayward, Vice President & Secretary
Date: January 29, 2026

I hereby certify that I am the Secretary of Casella Waste Management N.Y., Inc., and the above vote has not been amended or rescinded and remains in full force and effect as of the date of this certificate.

Signature:





CERTIFICATE OF LIABILITY INSURANCE

DATE (MM/DD/YYYY)
01/27/2026

THIS CERTIFICATE IS ISSUED AS A MATTER OF INFORMATION ONLY AND CONFERS NO RIGHTS UPON THE CERTIFICATE HOLDER. THIS CERTIFICATE DOES NOT AFFIRMATIVELY OR NEGATIVELY AMEND, EXTEND OR ALTER THE COVERAGE AFFORDED BY THE POLICIES BELOW. THIS CERTIFICATE OF INSURANCE DOES NOT CONSTITUTE A CONTRACT BETWEEN THE ISSUING INSURER(S), AUTHORIZED REPRESENTATIVE OR PRODUCER, AND THE CERTIFICATE HOLDER.

IMPORTANT: If the certificate holder is an ADDITIONAL INSURED, the policy(ies) must have ADDITIONAL INSURED provisions or be endorsed. If SUBROGATION IS WAIVED, subject to the terms and conditions of the policy, certain policies may require an endorsement. A statement on this certificate does not confer rights to the certificate holder in lieu of such endorsement(s).

PRODUCER Alera Group, Inc. 119 River Street Montpelier VT 05602	CONTACT NAME: Audrey Macle	
	PHONE (A/C, No, Ext): (802) 223-7735 FAX (A/C, No): (802) 223-7515 E-MAIL ADDRESS: casella@rwjinsurance.com	
INSURED Casella Waste Management of NY, Inc. 411 Route 146 Clifton Park NY 12065	INSURER(S) AFFORDING COVERAGE	NAIC #
	INSURER A: Westchester Fire Insurance Company	10030
	INSURER B: Old Republic Insurance Co.	24147
	INSURER C: The Cincinnati Casualty Company	28665
	INSURER D:	
	INSURER E:	

COVERAGES CERTIFICATE NUMBER: CWMNY Clifton Park REVISION NUMBER:

THIS IS TO CERTIFY THAT THE POLICIES OF INSURANCE LISTED BELOW HAVE BEEN ISSUED TO THE INSURED NAMED ABOVE FOR THE POLICY PERIOD INDICATED. NOTWITHSTANDING ANY REQUIREMENT, TERM OR CONDITION OF ANY CONTRACT OR OTHER DOCUMENT WITH RESPECT TO WHICH THIS CERTIFICATE MAY BE ISSUED OR MAY PERTAIN, THE INSURANCE AFFORDED BY THE POLICIES DESCRIBED HEREIN IS SUBJECT TO ALL THE TERMS, EXCLUSIONS AND CONDITIONS OF SUCH POLICIES. LIMITS SHOWN MAY HAVE BEEN REDUCED BY PAID CLAIMS.

INSR LTR	TYPE OF INSURANCE	ADDL INSD	SUBR WVD	POLICY NUMBER	POLICY EFF (MM/DD/YYYY)	POLICY EXP (MM/DD/YYYY)	LIMITS
A	<input checked="" type="checkbox"/> COMMERCIAL GENERAL LIABILITY <input type="checkbox"/> CLAIMS-MADE <input checked="" type="checkbox"/> OCCUR <input checked="" type="checkbox"/> XCU is Included GENL AGGREGATE LIMIT APPLIES PER: <input type="checkbox"/> POLICY <input checked="" type="checkbox"/> PRO-JECT <input type="checkbox"/> LOC OTHER:	Y		G48824560 001	10/20/2025	04/30/2026	EACH OCCURRENCE \$ 2,000,000 DAMAGE TO RENTED PREMISES (Ea occurrence) \$ 1,000,000 MED EXP (Any one person) \$ 15,000 PERSONAL & ADV INJURY \$ 2,000,000 GENERAL AGGREGATE \$ 4,000,000 PRODUCTS - COM/PROP AGG \$ 4,000,000 \$
B	AUTOMOBILE LIABILITY <input checked="" type="checkbox"/> ANY AUTO <input checked="" type="checkbox"/> OWNED AUTOS ONLY <input type="checkbox"/> SCHEDULED AUTOS <input checked="" type="checkbox"/> HIRED AUTOS ONLY <input checked="" type="checkbox"/> NON-OWNED AUTOS ONLY <input checked="" type="checkbox"/> MCS-90 <input checked="" type="checkbox"/> CA 9948 Incl	Y		MWTB 311995 26	01/01/2026	01/01/2027	COMBINED SINGLE LIMIT (Ea accident) \$ 5,000,000 BODILY INJURY (Per person) \$ BODILY INJURY (Per accident) \$ PROPERTY DAMAGE (Per accident) \$ \$
B	<input checked="" type="checkbox"/> UMBRELLA LIAB <input checked="" type="checkbox"/> OCCUR <input checked="" type="checkbox"/> EXCESS LIAB <input type="checkbox"/> CLAIMS-MADE DED RETENTION \$			MWZX 315503 25	04/30/2025	04/30/2026	EACH OCCURRENCE \$ 2,000,000 AGGREGATE \$ Excess Auto Liability \$
B	WORKERS COMPENSATION AND EMPLOYERS' LIABILITY ANY PROPRIETOR/PARTNER/EXECUTIVE OFFICER/MEMBER EXCLUDED? (Mandatory in NH) If yes, describe under DESCRIPTION OF OPERATIONS below	Y/N N	N/A	MWC 311994 26	01/01/2026	01/01/2027	<input checked="" type="checkbox"/> PER STATUTE <input type="checkbox"/> OTHER E.L. EACH ACCIDENT \$ 1,000,000 E.L. DISEASE - EA EMPLOYEE \$ 1,000,000 E.L. DISEASE - POLICY LIMIT \$ 1,000,000
C	Excess Auto Liability			EXS0575546	04/30/2025	04/30/2026	\$3M XS \$7M Auto Liab \$3,000,000

DESCRIPTION OF OPERATIONS / LOCATIONS / VEHICLES (ACORD 101, Additional Remarks Schedule, may be attached if more space is required)

The Town of Clifton Park is Additional Insured under the General Liability and Auto Liability Policies on a Primary and Non-Contributory basis where required by written contract subject to the terms and conditions of each policy.

CERTIFICATE HOLDER	CANCELLATION
Town of Clifton Park Buildings & Grounds One Town Hall Plaza Clifton Park NY 12065	SHOULD ANY OF THE ABOVE DESCRIBED POLICIES BE CANCELLED BEFORE THE EXPIRATION DATE THEREOF, NOTICE WILL BE DELIVERED IN ACCORDANCE WITH THE POLICY PROVISIONS. AUTHORIZED REPRESENTATIVE 

© 1988-2015 ACORD CORPORATION. All rights reserved.



Workers' Compensation Board

CERTIFICATE OF NYS WORKERS' COMPENSATION INSURANCE COVERAGE

<p>1a. Legal Name & Address of Insured (use street address only)</p> <p>Casella Waste Management of NY, Inc. 411 Roue 146 Clifton Park, NY 12065</p> <p>Work Location of Insured (Only required if coverage is specifically limited to certain locations in New York State, i.e., a Wrap-Up Policy)</p>	<p>1b. Business Telephone Number of Insured 518-491-5292</p> <p>1c. NYS Unemployment Insurance Employer Registration Number of Insured 50-75293</p> <p>1d. Federal Employer Identification Number of Insured or Social Security Number 01-0329311</p>
<p>2. Name and Address of the Entity Requesting Proof of Coverage (Entity Being Listed as the Certificate Holder)</p> <p>Town of Clifton Park Buildings & Grounds One Town Hall Plaza Clifton Park, NY 12065</p>	<p>3a. Name of Insurance Carrier Old Republic Insurance Company</p> <p>3b. Policy Number of entity listed in box "1a" MWC 311994 26</p> <p>3c. Policy effective period 01/01/2026 to 01/01/2027</p> <p>3d. The Proprietor, Partners or Executive Officers are <input checked="" type="checkbox"/> included. (Only check box if all partners/officers included) <input type="checkbox"/> all excluded or certain partners/officers excluded.</p>

This certifies that the insurance carrier indicated above in box "3" insures the business referenced above in box "1a" for workers' compensation under the New York State Workers' Compensation Law. (To use this form, New York (NY) must be listed under Item 3A on the INFORMATION PAGE of the workers' compensation insurance policy). The Insurance Carrier or its licensed agent will send this Certificate of Insurance to the entity listed above as the certificate holder in box "2".

Will the carrier notify the certificate holder within 10 days of a policy being cancelled for non-payment of premium or within 30 days if cancelled for any other reason or if the insured is otherwise eliminated from the coverage indicated on this certificate prior to the end of the policy effective period? YES NO

This certificate is issued as a matter of information only and confers no rights upon the certificate holder. This certificate does not amend, extend or alter the coverage afforded by the policy listed, nor does it confer any rights or responsibilities beyond those contained in the referenced policy.

This certificate may be used as evidence of a Workers' Compensation contract of insurance only while the underlying policy is in effect.

Please Note: Upon cancellation of the workers' compensation policy indicated on this form, if the business continues to be named on a permit, license or contract issued by a certificate holder, the business must provide that certificate holder with a new Certificate of Workers' Compensation Coverage or other authorized proof that the business is complying with the mandatory coverage requirements of the New York State Workers' Compensation Law.

Under penalty of perjury, I certify that I am an authorized representative or licensed agent of the insurance carrier referenced above and that the named insured has the coverage as depicted on this form.

Approved by: Audrey Macie
(Print name of authorized representative or licensed agent of insurance carrier)

Approved by: Audrey Macie 01/27/2026
(Signature) (Date)

Title: Licensed Agent for Old Republic Insurance Company

Telephone Number of authorized representative or licensed agent of insurance carrier: (802)223-7735

Please Note: Only insurance carriers and their licensed agents are authorized to issue Form C-105.2. Insurance brokers are NOT authorized to issue it.

Workers' Compensation Law

Section 57. Restriction on issue of permits and the entering into contracts unless compensation is secured.

1. The head of a state or municipal department, board, commission or office authorized or required by law to issue any permit for or in connection with any work involving the employment of employees in a hazardous employment defined by this chapter, and notwithstanding any general or special statute requiring or authorizing the issue of such permits, shall not issue such permit unless proof duly subscribed by an insurance carrier is produced in a form satisfactory to the chair, that compensation for all employees has been secured as provided by this chapter. Nothing herein, however, shall be construed as creating any liability on the part of such state or municipal department, board, commission or office to pay any compensation to any such employee if so employed.
2. The head of a state or municipal department, board, commission or office authorized or required by law to enter into any contract for or in connection with any work involving the employment of employees in a hazardous employment defined by this chapter, notwithstanding any general or special statute requiring or authorizing any such contract, shall not enter into any such contract unless proof duly subscribed by an insurance carrier is produced in a form satisfactory to the chair, that compensation for all employees has been secured as provided by this chapter.



PERMIT
Under the Environmental Conservation Law (ECL)

Permittee and Facility Information

Permit Issued To: CASELLA WASTE MANAGEMENT OF N.Y., INC. 25 GREENS HILL LN RUTLAND, VT 05701 (802) 775-0325	Facility: Tabor Road Transfer Station 12 Tabor Rd Halfmoon, NY 12151
---	--

Facility Location: in HALFMOON in SARATOGA COUNTY
Facility Principal Reference Point: NYTM-E: 600.170361400313 NYTM-N:
4751.3504622693

Latitude: 42°54'29.5" Longitude: 73°46'22.4"

Authorized Activity: The continued operation of a 890 tons per day Transfer Facility. This is a modification of the facility's permit to accept non-hazardous industrial/special waste specifically approved in writing by the Department.

Permit Authorizations

Solid Waste Management - Under Article 27, Title 7
Permit ID 5-4138-00263/00001

New Permit	Effective Date: <u>12/27/2019</u>	Expiration Date: <u>12/26/2029</u>
Modification # 1	Effective Date: <u>7/14/2021</u>	Expiration Date: <u>12/26/2029</u>
Modification # 2	Effective Date: <u>9/26/2023</u>	Expiration Date: <u>12/26/2029</u>
Modification # 3	Effective Date: <u>6/24/2024</u>	Expiration Date: <u>12/26/2029</u>

NYSDEC Approval

By acceptance of this permit, the permittee agrees that the permit is contingent upon strict compliance with the ECL, all applicable regulations, and all conditions included as part of this permit.

Permit Administrator: BETH A MAGEE, Deputy Regional Permit Administrator
Address: NYSDEC Region 5 Warrensburg Sub-Office
232 Golf Course Rd
Warrensburg, NY 12885

Authorized Signature: *Beth A Magee* Digitally signed by Beth A. Magee
Date: 2024.06.24 10:06:58 -0400 Date 6 / 24 / 24



Permit Components

SOLID WASTE MANAGEMENT PERMIT CONDITIONS

GENERAL CONDITIONS, APPLY TO ALL AUTHORIZED PERMITS

NOTIFICATION OF OTHER PERMITTEE OBLIGATIONS

SOLID WASTE MANAGEMENT PERMIT CONDITIONS

1. **Conformance With Plans** All activities authorized by this permit must be in strict conformance with the permit application, plans and materials prepared by Daigler Engineering, P.C.; titled "NYS DEC Solid Waste Management Facility Permit Application Tabor Road Transfer Station"; last revised December 2019; and received by the DEC Division of Environmental Permits on on December 20, 2019, as well as the permit modification application and updated Facility Manual received on June 10, 2024. See Condition 4 for further detail..
2. **Submission Requirements** Unless otherwise specified, all submissions required by this permit shall be made to the Region 5 Office of the Department of Environmental Conservation (232 Golf Course Road, Warrensburg, NY 12885-1172), to the attention of the Division of Materials Management. The Department encourages electronic submittals.
3. **Regulations** All references to the 6 NYCRR Part 360 series in this permit refers to the regulations effective July 22, 2023.
4. **Operation Documents** The operation of the facility shall be in strict conformance with the provisions of this permit, the 6 NYCRR Part 360 series and the facility's documentation received by the Department on December 20, 2019, prepared by Daigler Engineering, P.C., as well as the permit modification application and updated Facility Manual received on June 10, 2024. The provisions of Part 360 shall take precedence over any facility document in instances where discrepancies may exist. The facility's documentation must be updated no less frequently than at each time an application to renew a permit under Part 360 is submitted.
5. **Comprehensive Recycling Analysis ("CRA")** Solid waste cannot be accepted which has been generated within a municipality that has either not completed a comprehensive recycling analysis or is not included in another municipality's comprehensive recycling analysis satisfying the requirements of Section 360.11 which has been approved by the Department and implemented the recyclables recovery program determined to be feasible by the analysis.
6. **Mandatory Source Separation** The Permittee must not accept solid waste that originates from a municipality that has not implemented a mandatory source separation law for recyclables.



7. **Design Capacity** The Permittee is authorized to accept a maximum of 890 tons per day combined C&D debris, MSW, recyclables and non-hazardous industrial/special waste specifically approved in writing by the Department.

8. **Material Storage** Storage, processing and management of waste and recyclables shall occur only in respective designated areas as described in the aforementioned facility documentation.

9. **Annual Report** An annual report must be submitted to the Department's Central Office in Albany and Region 5 Office by March 1 of each year. The permittee shall use forms provided by the Department.

10. **Third-Party Operators** The permittee shall require that any contractor, project engineer, or other person responsible for the overall operation and/or supervision of this facility reads, understands and complies with this permit, including all conditions to prevent environmental degradation.

11. **Financial Assurance** A revised closure cost estimate must be submitted annually as part of the annual report, including supporting justification to account for inflation and changes in facility conditions. If the closure cost changes, the financial assurance instrument must be adjusted accordingly and documentation demonstrating such must be included with the annual report.

GENERAL CONDITIONS - Apply to ALL Authorized Permits:

1. **Facility Inspection by The Department** The permitted site or facility, including relevant records, is subject to inspection at reasonable hours and intervals by an authorized representative of the Department of Environmental Conservation (the Department) to determine whether the permittee is complying with this permit and the ECL. Such representative may order the work suspended pursuant to ECL 71-0301 and SAPA 401(3).

The permittee shall provide a person to accompany the Department's representative during an inspection to the permit area when requested by the Department.

A copy of this permit, including all referenced maps, drawings and special conditions, must be available for inspection by the Department at all times at the project site or facility. Failure to produce a copy of the permit upon request by a Department representative is a violation of this permit.

2. **Relationship of this Permit to Other Department Orders and Determinations** Unless expressly provided for by the Department, issuance of this permit does not modify, supersede or rescind any order or determination previously issued by the Department or any of the terms, conditions or requirements contained in such order or determination.

3. **Applications For Permit Renewals, Modifications or Transfers** The permittee must submit a separate written application to the Department for permit renewal, modification or transfer of this



permit. Such application must include any forms or supplemental information the Department requires. Any renewal, modification or transfer granted by the Department must be in writing. Submission of applications for permit renewal, modification or transfer are to be submitted to:

Regional Permit Administrator
NYSDEC Region 5 Warrensburg Sub-Office
232 Golf Course Rd
Warrensburg, NY12885

4. Submission of Renewal Application The permittee must submit a renewal application at least 180 days before permit expiration for the following permit authorizations: Solid Waste Management.

5. Permit Modifications, Suspensions and Revocations by the Department The Department reserves the right to exercise all available authority to modify, suspend or revoke this permit. The grounds for modification, suspension or revocation include:

- a. materially false or inaccurate statements in the permit application or supporting papers;
- b. failure by the permittee to comply with any terms or conditions of the permit;
- c. exceeding the scope of the project as described in the permit application;
- d. newly discovered material information or a material change in environmental conditions, relevant technology or applicable law or regulations since the issuance of the existing permit;
- e. noncompliance with previously issued permit conditions, orders of the commissioner, any provisions of the Environmental Conservation Law or regulations of the Department related to the permitted activity.

6. Permit Transfer Permits are transferrable unless specifically prohibited by statute, regulation or another permit condition. Applications for permit transfer should be submitted prior to actual transfer of ownership.

NOTIFICATION OF OTHER PERMITTEE OBLIGATIONS
--

Item A: Permittee Accepts Legal Responsibility and Agrees to Indemnification

The permittee, excepting state or federal agencies, expressly agrees to indemnify and hold harmless the Department of Environmental Conservation of the State of New York, its representatives, employees, and agents ("DEC") for all claims, suits, actions, and damages, to the extent attributable to the permittee's acts or omissions in connection with the permittee's undertaking of activities in connection with, or operation and maintenance of, the facility or facilities authorized by the permit whether in compliance or not in compliance with the terms and conditions of the permit. This indemnification does not extend to any claims, suits, actions, or damages to the extent attributable to DEC's own negligent or intentional acts or omissions, or to any claims, suits, or actions naming the DEC and arising under Article 78 of the New York Civil Practice Laws and Rules or any citizen suit or civil rights provision under federal or state laws.



Item B: Permittee's Contractors to Comply with Permit

The permittee is responsible for informing its independent contractors, employees, agents and assigns of their responsibility to comply with this permit, including all special conditions while acting as the permittee's agent with respect to the permitted activities, and such persons shall be subject to the same sanctions for violations of the Environmental Conservation Law as those prescribed for the permittee.

Item C: Permittee Responsible for Obtaining Other Required Permits

The permittee is responsible for obtaining any other permits, approvals, lands, easements and rights-of-way that may be required to carry out the activities that are authorized by this permit.

Item D: No Right to Trespass or Interfere with Riparian Rights

This permit does not convey to the permittee any right to trespass upon the lands or interfere with the riparian rights of others in order to perform the permitted work nor does it authorize the impairment of any rights, title, or interest in real or personal property held or vested in a person not a party to the permit.

NEW YORK STATE DEPARTMENT OF ENVIRONMENTAL CONSERVATION
DIVISION OF MATERIALS MANAGEMENT

PART 364
WASTE TRANSPORTER REGISTRATION NO. 5A-954

Pursuant to Article 27, Titles 3 and 15 of the Environmental Conservation Law and 6 NYCRR 364

REGISTRATION ISSUED TO:

CASELLA WASTE MANAGEMENT OF NY, INC.
(CLIFTON PARK HAULING)
1626 ROUTE 9
CLIFTON PARK, NY 12065

REGISTRATION TYPE:

- NEW
 RENEWAL
 MODIFICATION

CONTACT NAME: MICHAEL STEHMAN/SHANNON SCHAEFER
COUNTY: SARATOGA
TELEPHONE NO: (518)937-2350

EFFECTIVE DATE: 12/01/20
EXPIRATION DATE: 11/30/20

WASTE TYPES TO BE TRANSPORTED

The Registrant is Authorized to Transport the Following Waste Type(s):

Commercial Solid Waste [364-3.1(c)]

Waste Tires [364-3.1(f)]

Household Hazardous Waste [364-3.1(b)]

Construction and Demolition Debris [364-3.1(d)]

6 NYCRR Part 364 Registrations do not specify vehicles or receiving facilities.

NOTE: By acceptance of this registration, the registrant agrees that the registration is contingent upon strict compliance with the Environmental Conservation Law, and all applicable regulations.

ADDRESS:

New York State Department of Environmental Conservation
Division of Materials Management - Waste Transporter Program
625 Broadway, 9th Floor
Albany, NY 12233-7251

AUTHORIZED SIGNATURE: Laura Stevens Digitally signed by Laura Stevens
Date: 2025.12.02 09:26:56 -0500 Date: / /

PAGE

NEW YORK STATE DEPARTMENT OF ENVIRONMENTAL CONSERVATION
DIVISION OF MATERIALS MANAGEMENT

PART 364
WASTE TRANSPORTER REGISTRATION NO. 5A-954

Pursuant to Article 27, Titles 3 and 15 of the Environmental Conservation Law and 6 NYCRR 364

REGISTRATION ISSUED TO:

CASELLA WASTE MANAGEMENT OF NY, INC.
(CLIFTON PARK HAULING)
1626 ROUTE 9
CLIFTON PARK, NY 12065

REGISTRATION TYPE:

- NEW
 RENEWAL
 MODIFICATION

CONTACT NAME:
COUNTY:
TELEPHONE NO:

MICHAEL STEHMAN/SHANNON SCHAEFER
SARATOGA
(518)937-2350

EFFECTIVE DATE: 12/01/2025
EXPIRATION DATE: 11/30/2026

WASTE TYPES TO BE TRANSPORTED

The Registrant Is Authorized to Transport the Following Waste Type(s):

Commercial Solid Waste [364-3.1(c)]

Waste Tires [364-3.1(f)]

Household Hazardous Waste [364-3.1(b)]

Construction and Demolition Debris [364-3.1(d)]

6 NYCRR Part 364 Registrations do not specify vehicles or receiving facilities.

NOTE: By acceptance of this registration, the registrant agrees that the registration is contingent upon strict compliance with the Environmental Conservation Law, and all applicable regulations.

ADDRESS:

New York State Department of Environmental Conservation
Division of Materials Management - Waste Transporter Program
825 Broadway, 9th Floor
Albany, NY 12233-7251

AUTHORIZED SIGNATURE: Laura Stevens Digitally signed by Laura Stevens
Date: 2025.12.02 09:56:56 -0500 Date: ____/____/____

NEW YORK STATE DEPARTMENT OF ENVIRONMENTAL CONSERVATION
DIVISION OF MATERIALS MANAGEMENT

PART 364
WASTE TRANSPORTER PERMIT NO. 5A-954

Pursuant to Article 27, Titles 3 and 15 of the Environmental Conservation Law and 6 NYCRR 364

PERMIT ISSUED TO:

CASELLA WASTE MANAGEMENT OF NY, INC.
1626 ROUTE 9
CLIFTON PARK, NY 12065

PERMIT TYPE:

- NEW
 RENEWAL
 MODIFICATION

CONTACT NAME: MICHAEL STEHMAN
COUNTY: SARATOGA
TELEPHONE NO: (518)937-2350

EFFECTIVE DATE: 08/21/2025
EXPIRATION DATE: 08/20/2026
US EPA ID NUMBER:

AUTHORIZED WASTE TYPES BY DESTINATION FACILITY:

The Permittee is Authorized to Transport the Following Waste Type(s) to the Destination Facility listed :

Destination Facility	Location	Waste Type(s)	Note
Chemung County Sanitary Landfill	Chemung , NY	Non-Hazardous Industrial/Commercial	
Clinton County Landfill	Morrisonville , NY	Non-Hazardous Industrial/Commercial	
CWM-LATHAM TRANSFER STATION	LATHAM , NY	Non-Hazardous Industrial/Commercial	
Green Ridge RDF	Gansevoort , NY	Non-Hazardous Industrial/Commercial	
Hiram Hollow Regeneration Corp	Gansevoort , NY	Non-Hazardous Industrial/Commercial	
Menands Transfer Station	Menands , NY	Non-Hazardous Industrial/Commercial	
Ontario County Sanitary Landfill	Stanley , NY	Non-Hazardous Industrial/Commercial	
Tabor Road Transfer Station	Halfmoon , NY	Non-Hazardous Industrial/Commercial Waste Tires	
Wheelabrator Hudson Falls	Hudson Falls , NY	Waste Tires	

NOTE: By acceptance of this permit, the permittee agrees that the permit is contingent upon strict compliance with the Environmental Conservation Law, all applicable regulations, and the General Conditions printed on the back of this page.

ADDRESS:

New York State Department of Environmental Conservation
Division of Materials Management - Waste Transporter Program
626 Broadway, 9th Floor
Albany, NY 12233-7251

AUTHORIZED SIGNATURE: Patricia A. Leonardo Digitally signed by Patricia A. Leonardo
Date: 2025.08.17 13:02:48 -0400 Date: / /

NEW YORK STATE DEPARTMENT OF ENVIRONMENTAL CONSERVATION
DIVISION OF MATERIALS MANAGEMENT

PART 364
WASTE TRANSPORTER PERMIT NO. 5A-954

Pursuant to Article 27, Titles 3 and 15 of the Environmental Conservation Law and 6 NYCRR 364

PERMIT ISSUED TO:

CASELLA WASTE MANAGEMENT OF NY, INC.
1626 ROUTE 9
CLIFTON PARK, NY 12065

PERMIT TYPE:

- NEW
 RENEWAL
 MODIFICATION

CONTACT NAME: MICHAEL STEHMAN
COUNTY: SARATOGA
TELEPHONE NO: (518)937-2350

EFFECTIVE DATE: 08/21/2025
EXPIRATION DATE: 08/20/2026
US EPA ID NUMBER:

AUTHORIZED VEHICLES:

The Permittee is Authorized to Operate the Following Vehicles to Transport Waste:

(Vehicles enclosed in <>'s are authorized to haul Residential Raw Sewage and/or Septage only)

29 (Twenty Nine) Permitted Vehicle(s)

NY 15521BR
NY 15522BR
NY 15523BR
NY 15524BR
NY 20175BR
NY 20176BR
NY 20178BR
NY 20179BR
NY 20181BR
NY 20182BR
NY 2983D9
NY 2984D9
NY 2986D9
NY 2987D9
NY 2988D9
NY 2989D9
NY 2990D9
NY 2991D9
NY 2992D9
NY 2993D9
NY 2997D9
NY 2998D9
NY 2999D9
NY 3000D9
NY 3023D9
NY 3024D9
NY 3039D9
NY 41464PF
NY 41468PF
End of List

NEW YORK STATE DEPARTMENT OF ENVIRONMENTAL CONSERVATION
DIVISION OF MATERIALS MANAGEMENT

PART 364
WASTE TRANSPORTER PERMIT NO. 4A-756

Pursuant to Article 27, Titles 3 and 15 of the Environmental Conservation Law and 6 NYCRR 364

PERMIT ISSUED TO:

CASELLA WASTE MANAGEMENT, INC.
136 SICKER ROAD
LATHAM, NY 12110

PERMIT TYPE:

- NEW
 RENEWAL
 MODIFICATION

CONTACT NAME:
COUNTY:
TELEPHONE NO:

JOHN CASELLA/SHANNON SCHAEFER
ALBANY
(518)556-8756

EFFECTIVE DATE:
EXPIRATION DATE:
US EPA ID NUMBER:

09/24/2025
09/23/2026

AUTHORIZED WASTE TYPES BY DESTINATION FACILITY:

The Permittee is Authorized to Transport the Following Waste Type(s) to the Destination Facility listed :

Destination Facility	Location	Waste Type(s)	Note
Agri-Cycle of Washington County Inc	Buskirk , NY	Non-Hazardous Industrial/Commercial	
Albany (City) SWMF	Albany , NY	Non-Hazardous Industrial/Commercial	
Amsterdam Transfer Station	Amsterdam , NY	Non-Hazardous Industrial/Commercial Waste Tires Sludge from Sewage or Water Supply Treatment Plant	
BBC Aggregate Recycling (Albany)	Albany , NY	Non-Hazardous Industrial/Commercial	
CD Man LLC Transfer Station	Albany , NY	Non-Hazardous Industrial/Commercial	
Clifton Park Transfer Station	Clifton Park , NY	Non-Hazardous Industrial/Commercial Waste Tires	
Clinton County Landfill	Morrisonville , NY	Non-Hazardous Industrial/Commercial	
Colonie (T) SWMF	Colonie , NY	Non-Hazardous Industrial/Commercial	
County Waste Transfer Corp. - Troy TS	Troy , NY	Non-Hazardous Industrial/Commercial	
CWM-LATHAM TRANSFER STATION	LATHAM , NY	Non-Hazardous Industrial/Commercial	
Fulton County Landfill	Johnstown , NY	Non-Hazardous Industrial/Commercial	
Green Ridge RDF	Gansevoort , NY	Non-Hazardous Industrial/Commercial	
Hiram Hollow Regeneration Corp	Gansevoort , NY	Non-Hazardous Industrial/Commercial	
Menands Transfer Station	Menands , NY	Non-Hazardous Industrial/Commercial	
Murphy Rolloff Inc	Latham , NY	Non-Hazardous Industrial/Commercial	
Ontario County Sanitary Landfill	Stanley , NY	Non-Hazardous Industrial/Commercial Sludge from Sewage or Water Supply Treatment Plant	

*** AUTHORIZED WASTE TYPES BY DESTINATION FACILITY LISTING (continued on next page) ***

NOTE: By acceptance of this permit, the permittee agrees that the permit is contingent upon strict compliance with the Environmental Conservation Law, all applicable regulations, and the General Conditions printed on the back of this page.

ADDRESS:

New York State Department of Environmental Conservation
Division of Materials Management - Waste Transporter Program
625 Broadway, 9th Floor
Albany, NY 12233-7251

AUTHORIZED SIGNATURE: _____

Patricia Leonardo
Digitally signed by Patricia Leonardo
Date: 2025.09.23 13:57:01 -0400

Date: ____/____/____

NEW YORK STATE DEPARTMENT OF ENVIRONMENTAL CONSERVATION
 DIVISION OF MATERIALS MANAGEMENT

PART 364
WASTE TRANSPORTER PERMIT NO. 4A-756

Pursuant to Article 27, Titles 3 and 15 of the Environmental Conservation Law and 6 NYCRR 364

PERMIT ISSUED TO:

CASELLA WASTE MANAGEMENT, INC.
 136 SICKER ROAD
 LATHAM, NY 12110

PERMIT TYPE:

- NEW
 RENEWAL
 MODIFICATION

CONTACT NAME: JOHN CASELLA/SHANNON SCHAEFER
 COUNTY: ALBANY
 TELEPHONE NO: (518)556-6756

EFFECTIVE DATE: 09/24/2025
 EXPIRATION DATE: 09/23/2026
 US EPA ID NUMBER:

AUTHORIZED WASTE TYPES BY DESTINATION FACILITY: (Continued)

The Permittee is Authorized to Transport the Following Waste Type(s) to the Destination Facility listed :

Destination Facility	Location	Waste Type(s)	Note
Schenectady (City) Transfer Station	Schenectady , NY	Non-Hazardous Industrial/Commercial	
SM Gallivan Aggregates LLC	Watervliet , NY	Non-Hazardous Industrial/Commercial	
Tabor Road Transfer Station	Halfmoon , NY	Non-Hazardous Industrial/Commercial	
W.M. Biers Compost Facility	Albany , NY	Non-Hazardous Industrial/Commercial	
Washington County Compost Facility	Hudson Falls , NY	Non-Hazardous Industrial/Commercial Sludge from Sewage or Water Supply Treatment Plant	
Waste Management of New York POA Transfer Station	Albany , NY	Non-Hazardous Industrial/Commercial	
Waste Management of NY (Poestenkill)	Poestenkill , NY	Non-Hazardous Industrial/Commercial	
Wheelabrator Hudson Falls	Hudson Falls , NY	Non-Hazardous Industrial/Commercial Waste Tires	

NEW YORK STATE DEPARTMENT OF ENVIRONMENTAL CONSERVATION
DIVISION OF MATERIALS MANAGEMENT

PART 364
WASTE TRANSPORTER PERMIT NO. 4A-756

Pursuant to Article 27, Titles 3 and 15 of the Environmental Conservation Law and 6 NYCRR 364

PERMIT ISSUED TO:

CASELLA WASTE MANAGEMENT, INC.
136 SICKER ROAD
LATHAM, NY 12110

PERMIT TYPE:

- NEW
 RENEWAL
 MODIFICATION

CONTACT NAME: JOHN CASELLA/SHANNON SCHAEFER
COUNTY: ALBANY
TELEPHONE NO: (518)556-6756

EFFECTIVE DATE: 09/24/2025
EXPIRATION DATE: 09/23/2026
US EPA ID NUMBER:

AUTHORIZED VEHICLES:

The Permittee is Authorized to Operate the Following Vehicles to Transport Waste:

(Vehicles enclosed in <>'s are authorized to haul Residential Raw Sewage and/or Septage only)

30 (Thirty) Permitted Vehicle(s)

NY 25737MM
NY 26100MN
NY 26101MN
NY 26102MN
NY 26103MN
NY 26105MN
NY 26123MN
NY 26231MN
NY 26235MN
NY 26237MN
NY 26238MN
NY 26239MN
NY 32829PF
NY 34849MN
NY 38406NC
NY 39207NA
NY 40344PF
NY 48042NG
NY 53677NE
NY 62175NA
NY 68476NF
NY 70403NC
NY 81940NE
NY 85653PC
NY 85731PC
NY 85732PC
NY 92011ND
NY 92259ND
NY 96512NA
NY 98582NE
End of List



RESOLUTION

#15

PHILIP C. BARRETT
Supervisor

AGATHA REID
Councilwoman

ZABED MANIR
Councilman

NANCY R. BELLAMY
Councilwoman

MARIO L. FANTINI
Councilman

Resolution No. _____ of 2026, a resolution authorizing the purchase of one 2026 Ford F-350 pickup truck with snowplow and salter, for use by the Sewer Department, from an existing New York State (NYS) mini bid.

Introduced by _____, who moved its adoption, seconded by _____.

WHEREAS, Mike O'Brien, Collection Systems Manager, has recommended the purchase of a 2026 Ford F-350 Regular Cab truck with plow and salter to replace the department's 2016 Ford F-250 truck and salter, and

WHEREAS, the prices quoted are extended from NYS Mini Bid 1126-022, OGS Solicitation 23166, under the provisions of NYS General Municipal Law Section 103 which allows one municipality to utilize existing contracts of another municipality as long as that contract was pursuant to competitive bidding consistent with state law and made available for use by other government entities, and

WHEREAS, General Municipal Law Section 103(16) allows the extension of equipment configurations and awarded pricing discounts to all political subdivisions in New York State based upon qualified bid responses to a municipal entity, with notice, and

WHEREAS, Mr. O'Brien advises that the lowest responsive bid pricing for the truck and attachments is from Scorpio Motors LLC, DBA Greenwich Ford, and recommends accepting this bid for a total amount not to exceed \$65,156; now, therefore, be it

RESOLVED, that the Sewer Department is authorized to purchase one 2026 Ford F-350 pickup truck with plow and salter, as detailed in the attached; and be it further

RESOLVED, that the Town Board authorizes the purchase under NYS Mini Bid 1126-022, OGS Solicitation #23166, in an amount not to exceed \$65,156, to be paid through municipal lease.

Cynthia Zlogar

From: Town of Clifton Park Official Website <info@cliftonpark.org>
Sent: Tuesday, January 27, 2026 9:37 AM
To: Cynthia Zlogar; Phil Barrett; Jean Spiegel; Mark Heggen; Darlene Allen; Zabed Manir; Agatha Reid; John Scavo; Christine Pagniello; Walter Smead; Kelly Miller; Nancy Bellamy; Mario Fantini; Kevin Dailey; Caitlin Fantini
Subject: New Resolution Request #2513

A new resolution request has been submitted. The details of this resolution request are included below.

Department: Sewer

Your Name: Michael O'Brien

Your Email: mobrien@cliftonpark.org

Sponsor: Barrett

Agenda Session Date: 02/03/2026 ✓

Board Meeting Date: 02/24/2026 ✓

Alternate Date: 02/03/2026

Budget Number: G11-8111-200

Budget Description: Equip And Build

Amount: \$65,155.44

Brief Description: Purchase new 2026 F350 Reg Cab truck with Boss V-Plow and Boss Salter for the Town Sewer Dept. This truck will replace the 2016 F250 and Salter both. Bids procured via NYS Vehicle Market Place Mini Bid system. Greenwich Ford was the lowest bidder meeting Town Spec. Town will utilize municipal leasing options

Add Supporting Docs:

[92d79ff78ee01351_award-23166-response-ranking-tool-single-oem-2025-04-29-11_3.xlsx](#)

[75b47559e5ec67ad_OGS_23166 - 1126-022 - 1_Full Size Pickup Truck - 4x4 -](#)

[_Town of Clifton Park Sewer Dept. - Specs.docx](#)

[e555b0c158dc142a_Greenwich_F350.xlsx](#)

Additional Comments/Details: As budgeted

Agree to Terms: Agree

[unsubscribe](#)

1/15/26

Town of Clifton Park Sewer Department 2025/26 Truck Spec. F-350

2025/2026 Ford Super Duty F-350 XL Regular Cab, 8' Box.

6.2-liter Flex Fuel V8

Torq Shift Heavy Duty 6 Speed Transmission

3.73 Locking Axle Ratio

4x4 SRW

White

Snowplow Prep

10,000/9,900 GVWR

Rear window Defog

Extending Mirrors w/heat

Skid Plates

Aluminum Body and Bed

LED ROOF Markers/Clearance lights

Upfitter switches

240 Amp Alternator

Mud flaps front and rear

Exterior back up alarm

Platform running boards

40/20/40 seats vinyl

Integrated trailer Brake Controller

110 Volt / 400-Watt Ac Outlet

Am/FM stereo (sync)

Air Conditioning

176" Wheelbase

Aftermarket items Installed.

Boss 8'2V DXT with Down Force, Deflector, Installed

Boss VBX+ 2 Yard Pintle, Product Number: VBS26210 installed

Bedliner Spray in

Narrow Crossover Style - Aluminum – Tool Box. 12” wide (front to back)

LED roof Mount Light Bar (Whelen Responder HD Amber) wired to Upfitter switches

Group 40440-23166, VEHICLES, Class 1-8 (Vehicle Marketplace)

Form B (Single OEM Vehicle): Mini-Bid Response

Form Revision: 04/29/2025

Part A: Mini-Bid and Contractor Information		Contractor Response
1.0	Mini-Bid Questions	
1.1	Mini-Bid Reference Number (e.g. 12345; see the <i>Mini-Bid Request</i>)	1126-022
1.2	Is the Mini-Bid for Vehicle(s) to be purchased or leased by the Authorized User? <i>[click on yellow box and use drop-down menu]</i>	Purchased
1.3	Are Vehicle(s) Built to Specifications being offered in response to the Mini-Bid? <i>[click on yellow box and use drop-down menu]</i>	Yes, Part B of this form has been completed.
1.4	Are Pre-Existing Inventory Vehicle(s) being offered in response to the Mini-Bid? <i>[click on yellow box and use drop-down menu]</i>	No, Part C of this form has been left blank.
2.0	Contractor Information	
2.1	Full Legal Business Name, including DBA if applicable	Scopic Motors LLC DBA Greenwich Ford
2.2	OGS Contract Number (e.g., PC12345)	PC69492
2.3	Federal Employer Identification Number / FEIN (e.g. 14-1234567)	862135447
2.4	NYS Vendor ID Number (e.g. 100012345)	1100263134
3.0	Primary Contact Information	
3.1	Contact Name	Mark Robillard
3.2	Contact Email	mrobillard@greenwichford.com
3.3	Contact Phone (1)	518 247-6973
3.4	Contact Phone (2)	518 692-2246
4.0	Secondary Contact Information	
4.1	Contact Name	Dan Forant
4.2	Contact Email	dforant@greenwichford.com
4.3	Contact Phone	518 247-6941

Part B: Vehicle(s) Built to Specifications offered for Mini-Bid		Contractor Response
1.0	General Questions (Built to Spec)	
1.1	Does the Vehicle offered meet all Authorized User Specifications for the requested Vehicle? <i>(Note: General specifications, and an "Additional Vehicle Specifications Document(s)" are included with each Mini-Bid Request)</i>	Yes
1.2	Enter the estimated number of days after receipt of a Purchase Order, or other ordering document, that the delivery will be made.	80
1.3	Enter the Final Order Due Date for the Vehicle offered for the Mini-Bid, or "TBA" if the date has not been announced by the manufacturer.	TBA
1.4	If the Vehicle is a ZEV (see definition), will final assembly of the Vehicle occur in the United States? <i>[click on yellow box and use drop-down menu]</i>	

2.0	Vehicle Offered (Built to Spec)		
2.1	Model Year (e.g., 2023, 2024)	2026	
2.2	Make (e.g., Ford, Chevrolet, Dodge)	Ford	
2.3	Model (e.g., Taurus, Tahoe, Grand Caravan), and Trim Level (e.g., SE, LE, XL)	F-350	
2.4	Model Code (the OEM code used to identify a particular subset of a Vehicle Model)	F3B	
2.5	Drive Type (click on yellow box and use drop-down menu)	4x4	
	If the offered Drive Type is not included in the drop-down menu, enter it here		
2.6	Fuel Type (click on yellow box and use drop-down menu)	Gasoline Only	
	If the offered Fuel Type is not included in the drop-down menu, enter it here		
2.7	Enter the vendor business name(s) of the Aftermarket Component's Provider(s), if applicable. If not applicable, enter "N/A".	Legacy Equipment LLC	
3.0	Additional Information (Built to Spec)		
3.1	If applicable, enter any deviations from the Authorized User Specifications, or other additional information applicable to this Mini-Bid. Bidders are strongly encouraged to submit proposed deviations to the Authorized User by email prior to the Mini-Bid Response Due Date, so that they may be given due consideration prior to the submission of bids. Do not enter information about Options or Aftermarket Components available for the Vehicle offered, unless it has been included in the Authorized User Specifications. If not applicable, enter "N/A".		
	N/A		
4.0	Vehicle Price Worksheet (Built to Spec)		Price
4.1	NYS Base MSRP		\$66,325.00
4.2	NYS Discount (Type a number only (e.g., 5.5). Do not type a percentage sign (%) after the number. For 5.5% type 5.5, not 0.055).		15.25
4.3	NYS Base Price (Automatically calculated: NYS Base MSRP minus NYS Discount)		\$47,735.44
4.4	NYS Aftermarket Components Price (If there are no Aftermarket Components, leave blank)		\$17,420.00
4.5	NYS Price for the Vehicle (Automatically calculated: NYS Base Price plus NYS Aftermarket Component Prices)		\$65,155.44
4.6	Number of Vehicles (This quantity must match the Number of Vehicles specified by the Authorized User in the Mini-Bid Request)		1
4.7	Total Price for Mini-Bid (Automatically calculated: NYS Price for the Vehicle multiplied by Total Number of Vehicles)		\$66,155.44



Part C: Pre-Existing Inventory Vehicle(s) offered for Mini-Bid

1.0 General Questions (Pre-Existing)	Contractor Response
1.1 Do the Vehicle(s) offered meet all Authorized User Specifications for the requested Vehicle? <i>(click on yellow box and use drop-down menu)</i> <i>(Note: General specifications, and an "Additional Vehicle Specifications Document" are included with each Mini-Bid Request. A Vehicle offered that does not meet all Authorized User Specifications may be deemed non-responsive and may be rejected).</i>	
1.2 Will the Vehicle(s) and pricing offered for the Mini-Bid Responses remain firm and not be withdrawn for at least ten (10) calendar days from the first business day immediately following the Mini-Bid response submittal deadline, or such other period of time as specified in the Mini-Bid Request, in accordance with the Contract (see Section 2.42 Procurement Method, Paragraph G Timeframe for Offers in Mini-Bids)? <i>(click on yellow box and use drop-down menu)</i>	
1.3 If the Vehicle(s) offered are ZEVs (see definition), did final assembly of the Vehicle(s) occur in the United States? <i>(click on yellow box and use drop-down menu)</i>	
2.0 Additional Information (Pre-Existing)	
2.1 If applicable, enter any deviations from the Authorized User Specifications, or other additional information applicable to this Mini-Bid. Bidders are strongly encouraged to submit proposed deviations to the Authorized User by email prior to the Mini-Bid Response Due Date, so that they may be given due consideration prior to the submission of bids. Do not enter information about Options or Aftermarket Components available for the Vehicle offered, unless it has been included in the Authorized User Specifications. If not applicable, enter "N/A".	
3.0 Vehicle Price Worksheet (Pre-Existing)	

(If more than fifteen (15) Pre-Existing Inventory Vehicles are being offered for a Mini-Bid, submit an additional completed Form B (Single OEM Vehicle): Mini-Bid Response form for the Mini-Bid. Submit both Form Bs following the instructions at the top of this Form, using the following naming convention for the additional Form B "OGS 23166-XXXXXXX-PC12345-Additional Vehicles" (i.e., OGS Award#-Mini-Bid Reference#-Contract#-Additional Vehicles).

Ref. #	Model Year	Make	Model and Trim Level	Model Code	Exterior Color	Interior Color	Seat Fabric	Drive Type	Fuel Type	NYS Base MSRP	NYS Discount	NYS Base Price	NYS Aftermarket Components Price	NYS Price for Vehicle	Final Assembly in USA?
(Example)	2023	Chevrolet	Traverse	CV14526	Blue Metallic	Dark Titanium	Cloth	FWD	Gasoline	\$41,500.00	5.00	\$39,425.00	\$1,500.00	\$40,925.00	Yes
001															
002															
003															
004															
005															
006															
007															
008															
009															
010															
011															
012															
013															
014															
015															
Total Price for Mini-Bid														\$0.00	
Total Pre-Existing Vehicles Offered														0	



RESOLUTION

#16

PHILIP C. BARRETT
Supervisor

AGATHA REID
Councilwoman

ZABED MANIR
Councilman

NANCY R. BELLAMY
Councilwoman

MARIO L. FANTINI
Councilman

Resolution No. _____ of 2026, a resolution authorizing the purchase of a 2026 Ford Transit 250 HR van for use by the Sewer Department.

Introduced by _____, who moved its adoption, seconded by _____.

WHEREAS, Mike O'Brien, Collection Systems Manager, has identified a need for a new grinder pump service vehicle to replace the current department vehicle, and

WHEREAS, Mr. O'Brien has recommended that a 2026 Ford Transit HR grinder pump service van, available from Schultz Ford Lincoln, Inc., be purchased under NYS Mini-bid #1126-026, OGS Solicitation 23166, at a cost of \$55,323; now, therefore, be it

RESOLVED, that the Clifton Park Town Board hereby authorizes the purchase of a 2026 Ford Transit HR grinder pump service van from Schultz Ford Lincoln, Inc., as described in the attached documents, at a cost not to exceed \$55,323 under NYS Mini-bid #1126-026, to be paid for by a municipal lease from G7-8111-145 (CP Sewer #1- Sewer Contractual – Lease Payments); and be it further

RESOLVED, that the Comptroller will obtain quotes for a lease at a mutually agreeable time.

Cynthia Zlogar

From: Town of Clifton Park Official Website <info@cliftonpark.org>
Sent: Wednesday, January 28, 2026 9:44 AM
To: Cynthia Zlogar; Phil Barrett; Jean Spiegel; Mark Heggen; Darlene Allen; Zabed Manir; Agatha Reid; John Scavo; Christine Pagniello; Walter Smead; Kelly Miller; Nancy Bellamy; Mario Fantini; Kevin Dailey; Caitlin Fantini
Subject: New Resolution Request #2517

A new resolution request has been submitted. The details of this resolution request are included below.

Department: Sewer

Your Name: Michael O'Brien

Your Email: mobrien@cliftonpark.org

Sponsor: Barrett

Agenda Session Date: 02/03/2026 ✓

Board Meeting Date: 02/24/2026 ✓

Alternate Date: 02/03/2026

Budget Number: G7-8111-200

Budget Description: Equip and Budget

Amount: Not to Exceed \$55,322.18

Brief Description: The Town of Clifton Park Sewer Department needs to replace an existing grinder pump service truck. The Town of Clifton Park Sewer Department has used the NYS Vehicle Market Place to procure pricing for a Transit Service Van. Low Bid is "TBD"

Add Supporting Docs:

Additional Comments/Details: as budgeted. Bids are due by Feb 2, 2026. I will have paperwork to Attorneys office after the close.

Agree to Terms: Agree

[unsubscribe](#)



RESOLUTION

#17

PHILIP C. BARRETT
Supervisor

AGATHA REID
Councilwoman

ZABED MANIR
Councilman

NANCY R. BELLAMY
Councilwoman

MARIO L. FANTINI
Councilman

Resolution No. _____ of 2026, a resolution correcting the appointment of Suzanne Moore as a member of the Board of Assessment Review.

Introduced by _____, who moved its adoption, seconded by _____.

WHEREAS, by Resolution No. 73 of 2022, Mrs. Moore was appointed to serve as an member of the Board of Assessment Review, term to expire December 31, 2025; and

WHEREAS, this resolution erroneously stated the term for Mrs. Moore as a three-year term, however the term should be a five-year term, and Mrs. Moore's term expiration date should be corrected to be September 30, 2027; now therefore be it

RESOLVED, that Suzanne Moore is hereby appointed as a member of the Board of Assessment Review for a five-year term, term to expire September 30, 2027.

Resolution No. 73 of 2022, a resolution appointing Suzanne Moore as a Member of the Board of Assessment Review.

Introduced by Councilwoman Standaert, who moved its adoption, seconded by Councilman Morelli.

WHEREAS, a vacancy exists on the Clifton Park Board of Assessment Review, and

WHEREAS, Supervisor Barrett recommends Suzanne Moore, 7 Belmonte Lane, Clifton Park, for the position; now, therefore, be it

RESOLVED, that Suzanne Moore, Clifton Park, is hereby appointed as a Member of the Board of Assessment Review with the term to expire on September 30, 2025.

ROLL CALL VOTE

Ayes: Councilwoman Flood, Councilwoman Standaert, Councilman Morelli,
Councilwoman Walowit, Supervisor Barrett

Noes: None

DECLARED ADOPTED

March 14, 2022

Teresa Brobston, Town Clerk



RESOLUTION

#18

PHILIP C. BARRETT
Supervisor

AGATHA REID
Councilwoman

ZABED MANIR
Councilman

NANCY R. BELLAMY
Councilwoman

MARIO L. FANTINI
Councilman

Resolution No. _____ of 2026, a resolution authorizing the Superintendent of Highways to hire Todd Nelson as a Motor Equipment Operator (MEO) in the Highway Department.

Introduced by _____, who moved its adoption, seconded by _____.

WHEREAS, after the retirement of Marc Pelc., an opening exists for an MEO in the Highway Department, and,

WHEREAS, Superintendent of Highways, Dahn Bull, has recommended the hiring of the following individual:

<u>Name</u>	<u>License Type</u>	<u>Address</u>
Todd Nelson	Class A	Stillwater, NY

and,

WHEREAS, Mr. Nelson has experience as a Class A driver driving large trucks and trailers throughout the region and brings with him the experience to drive and operate our large equipment hauling trailers; now, therefore, be it

RESOLVED, that the Town Board authorizes the hiring of Todd Nelson as a Motor Equipment Operator, at Grade 5, Step 1, at a salary of \$60,354, at a rate of \$28.91/hr., effective at a start date no earlier than March 1, 2026, to be paid as detailed in the attached Schedule A.

Cynthia Zlogar

From: Town of Clifton Park Official Website <info@cliftonpark.org>
Sent: Thursday, February 5, 2026 10:31 AM
To: Cynthia Zlogar; Phil Barrett; Jean Spiegel; Mark Heggen; Darlene Allen; Zabed Manir; Agatha Reid; John Scavo; Christine Pagniello; Walter Smead; Kelly Miller; Nancy Bellamy; Mario Fantini; Kevin Dailey; Caitlin Fantini
Subject: New Resolution Request #2560

A new resolution request has been submitted. The details of this resolution request are included below.

Department: Highway Department

Your Name: Dahn Bull

Your Email: dbull@cliftonpark.org

Sponsor: D. Bull

Agenda Session Date: 02/17/2026 ✓
24

Board Meeting Date: 02/17/2026 ✓
24

Alternate Date: 03/03/2026

Budget Number: DA-5110-E1500, DA-5142-E1500

Budget Description: Item 1 - Motor Equipment Operator, Item 4 - Motor Equipment Operator

Amount: Grade 5, Step 1 Salary - \$60,354.00, \$28.91/hr.

Brief Description: Resolution No. of 2026, a resolution authorizing the Superintendent of Highways to hire Todd Nelson as a Motor Equipment Operator in the Highway Department.

Introduced by Council _____, who moved its adoption, seconded by Council _____

WHEREAS, after the retire of Mark Pelc, vacancies exists in the Highway Department for Motor Equipment Operator, and

WHEREAS, Superintendent of Highways Dahn Bull, has recommended the hiring of the following individual:

Name License Type Address

Todd Nelson Class A 14 Kellogg Road, Stillwater
and,

WHEREAS, Mr. Nelson has experience as a Class A Driver driving large trucks and trailers throughout the Region, and brings with him the experience to drive and operate our large equipment hauling trailers; now, therefore be it,

RESOLVED, that the Town Board authorizes the hiring of Todd Nelson as a Motor Equipment Operator, at Grade 5, Step 1 Salary - \$60,354.00, \$28.91/hr. effective at a start date no earlier than March 1, 2026, and be it further,

RESOLVED, that Mr. Nelson be paid at the above-mentioned rate from budget line DA-5110-E1500 (Highway General Repairs-MEO), and budget line DA-5142-E1500 (Highway-Snow Removal-MEO), for the remainder of the calendar year, and be it further,

RESOLVED, that the Comptroller is authorized to transfer funds from DA-05110-E00 (Highway General Repairs-MEOs) of \$\$\$\$\$\$\$\$ to DA-5110-Exxxx (Highway General Repairs-MEOs) and \$\$\$\$\$\$\$\$ to DA-05142-Exxxx (Highway-Snow Removal-Employee).

Add Supporting Docs:

[69bb17b09db8e04e_T._Nelson_Application.pdf](#)

[b09e33da6096bc9b_T._Nelson_Drivers_Abstract.pdf](#)

[4c5905892cfb6435_T._Nelson_License.pdf](#)

Additional Comments/Details: Josiah Connolly, previously hired in November of 2025, was relieved of his duties with the Highway Department at the end of 90 day probationary period. Mr. Connolly took the position vacated by the retirement of Mark Pelc, Motor Equipment Operator.

Agree to Terms: Agree

[unsubscribe](#)

SCHEDULE A

Town of Clifton Park
Salary Allocation

		Grade	Step	Year	Hourly Rate	2026	Weeks to End of Year	Hours	Projected to End of Year
Laborer									
Todd	Nelson	5	1	1	28.91		43.8	40	\$ 50,650.32

Rounded to: \$ 50,700.00

Transfer funds from:

Highway Fund - Snow Removal - MEO	DA-05142-E1500	\$ 13,695.00
Highway Fund - General Construction - MEO	DA-05110-E1500	<u>\$ 37,005.00</u>

Transfer to:

Highway Fund - Snow Removal - T Nelson	DA-05142-Exxxx	\$ 13,695.00
Highway Fund - General Construction - T Nelson	DA-05110-Exxxx	<u>\$ 37,005.00</u>



RESOLUTION

#19

PHILIP C. BARRETT
Supervisor

•

AGATHA REID
Councilwoman

ZABED MANIR
Councilman

•

NANCY R. BELLAMY
Councilwoman

•

MARIO L. FANTINI
Councilman

Resolution No. ____ of 2026, a resolution amending Resolution No. 46 of 2025.

Introduced by _____, who moved its adoption, seconded by _____.

WHEREAS, by Resolution No. 46 of 2025, the Highway Superintendent was authorized to retain the services of DLC Electric of Troy, NY, for maintenance and repair of traffic signals for one (1) year, to expire as of February, 2026, and

WHEREAS, the Maintenance Contract Agreement between the Town and DLC Electric provides for an option to extend the contract for an additional period, and

WHEREAS, upon recommendation of the Highway Superintendent, it is the desire of the Town Board to extend the contract upon the same terms for an additional period of one year, until the end of February 2027; now, therefore, be it

RESOLVED, that the Highway Superintendent is authorized to extend the contract, as aforesaid, with DLC Electric, for an additional one (1) year period.

Resolution No. 46 of 2025, a resolution accepting a proposal from DLC Electric, LLC, Troy, NY, for the electrical maintenance, inspection and emergency repair of Clifton Park Traffic Signals and Crosswalks, and to transfer funds from Contingency.

Introduced by Councilwoman Walowit, who moved its adoption, seconded by Councilman Manir.

WHEREAS, the Town of Clifton Park is responsible for maintaining the operation of 10 traffic signals and crosswalks on Town-owned streets, and

WHEREAS, Dahn Bull, Highways Superintendent, received bids for the maintenance and emergency repairs on January 17, 2025, and

WHEREAS, DLC Electric, LLC, Troy, NY, submitted the sole conforming quote, in the same categories as listed on the attached quote cover sheet; now, therefore, be it

RESOLVED, that the Town Board authorizes Dahn Bull, Highways Superintendent, to retain DLC Electric at hourly rates quoted, to perform monthly preventative maintenance on all 10 signals, and emergency repair callouts on the traffic signals; and be it further

RESOLVED, that the monthly maintenance on the signals is estimated to be \$37,050 and the emergency callouts, based on past history, is estimated to be \$25,500, to be paid from A-03310-00215 (General Fund – Traffic Safety - Traffic Safety); and be it further

RESOLVED, that the Comptroller is authorized to transfer \$10,550 from Contingency (A-01990-00015) to A-03310-00215 (General Fund – Traffic Safety - Traffic Safety).

ROLL CALL VOTE

Ayes: Councilman Morelli, Councilwoman Reid, Councilman Manir,
Councilwoman Walowit, Supervisor Barrett

Noes: None

DECLARED ADOPTED

February 24, 2025

Stephanie Ranze, Town Clerk

TOWN OF CLIFTON PARK
CLIFTON PARK HIGHWAY DEPARTMENT TRAFFIC SIGNAL AGREEMENT

MAINTENANCE CONTRACT AGREEMENT

(To be filled out after Contract Award)

This is an Agreement made as of February 18th, 2025, by and between the Town of Clifton Park Highway Department (hereinafter called the OWNER), and DLC Electric, LLC (hereinafter called CONTRACTOR),

CONTRACTOR agrees to perform all Work in accordance with the Contract Documents for the TOWN OF CLIFTON PARK HIGHWAY DEPARTMENT TRAFFIC SIGNAL AND CROSSWALK MAINTENANCE CONTRACT, AND APPROVED THROUGH RESOLUTION 46 OF 2025 and to provide annual maintenance services as well as emergency maintenance calls to Clifton Park Traffic Signals and Crosswalks. Rates to be \$285.00/hour for regular maintenance visits, and \$850.00/hour for emergency call-ins, with annual maintenance cost of \$37,050.00.

OWNER agrees to pay CONTRACTOR in accordance with the Contract Documents on a monthly basis for the period of one year, with the option to extend the contract as of February, 2026. The CONTRACTOR shall accept as full and complete payment for the performance of this Contract subject to additions or deductions as provided in the Contract Documents.

IN WITNESS WHEREOF, the parties hereunto have reached this agreement:

AGREED TO:

AGREED TO:

TOWN OF CLIFTON PARK
(Owner's Name)

DLC Electric, LLC

BY: Dahn S. Bull

BY: Margaret Cioffi

[Signature]
(Authorized Signature/Date)

[Signature]
(Authorized Signature/Date)

TITLE:

TITLE:

SUPERINTENDENT OF HIGHWAYS

Managing Member

STATE OF NEW YORK }
COUNTY OF SARATOGA }

On this 3rd day of Mar, 2025, before me personally came DAHN S BULL to me known, who being by me duly sworn did depose and say that he resides at 326 ENALDGERD, BEXFORD that he is the SUPERINTENDENT of the corporation described in CLIFTON PARK HIGHWAY DEPARTMENT TRAFFIC SIGNAL AGREEMENT and which executed the foregoing instrument, that he knows the seal of said corporation; that the seal affixed to said instrument was such corporate seal; that it was so affixed by the order of the Board of Directors of said corporation and that he signed his name thereto like order.

[Signature]
Notary Public
Reg. No. 01F16403439
Qualified in Saratoga County
Commission Expires Jan 27, 2028

STATE OF NEW YORK }
COUNTY OF Rensselaer }

On this 10th day of March, 2025, before me personally came Margaret Cioffi to me known, who being by me duly sworn did depose and say that he resides at Gypsy Lane, Troy NY that he is the Managing Member of the corporation described in DLC LLC and which executed the foregoing instrument; that he knows the seal of said corporation; that the seal affixed to said instrument was such corporate seal; that it was so affixed by the order of the Board of Directors of said corporation and that he signed his name thereto like order.

[Signature]
Notary Public

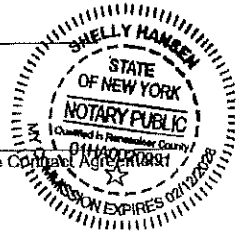

BID FORM
(to be returned with bid)

For: Town of Clifton Park
From: DLC Electric, LLC
Traffic Signal Maintenance & Repair

Date Bid Submitted: 1/17/25

The undersigned BIDDER proposes and agrees, if this Bid is accepted, to enter into an agreement with OWNER in the form included in the Contract Documents to perform and finish all work as specified or indicated in the Contract Documents for the Bid Price and within the Bid Times indicated in this Bid and in accordance with the other terms and conditions of the Contract Documents.

BIDDER accepts all of the terms and conditions of the Advertisement or Invitation to Bid and Information for Bidders, including without limitation those dealing with the disposition of Bid security. This Bid will remain subject to acceptance for forty-five days after the Bid opening. BIDDER will sign and deliver the required number of counterparts of the Agreement with the Bonds and other documents required by the Bidding Requirements within ten days after the date of OWNER'S Notice of Award.

In submitting this Bid, BIDDER represents, as more fully set forth in the Agreement, that: BIDDER has examined copies of all the Bidding Documents including Addenda.

Bidder has given ENGINEER written notice of all conflicts, errors, ambiguities or discrepancies that BIDDER has discovered in the Contract Documents and the written resolution thereof by OWNER is acceptable to BIDDER and the contract documents are generally sufficient to indicate and convey understanding of all terms and conditions for performing and furnishing the work for which this Bid is submitted.

This Bid is genuine and not made in the interest of or on behalf of any undisclosed person, firm, or corporation and is not submitted in conformity with any agreement or rules of any group, association, organization or corporation; BIDDER has not directly or indirectly induced or solicited any other Bidder to submit a false or Sham Bid. BIDDER has not solicited or induced any person, firm, or corporation to refrain from bidding, and BIDDER has not sought by collusion to obtain for itself any advantage over any other Bidder or over OWNER.

If the undersigned fails to execute the contract in the foregoing Notice to Bidders, within ten days from the date of notification of the awarding of the contract, the OWNER may, at its option, determine that the undersigned has forfeited the contract and certified check or bid bond accompanying this proposal shall be invoked as liquidated damages for such failure; otherwise it shall be returned to the undersigned.

*WYS DOT
Waterworks
Colonie TN
Schultz*

*- 10:30 AM
Freddy
1/24/25*

TOWN OF CLIFTON PARK

NON-COLLUSIVE BIDDING CERTIFICATION

(Required by Section I 03-d of the New York State General Municipal Law)

By Submission of this Bid, each Bidder and each person signing on behalf of any Bidder certifies, and in case of a joint Bid each party thereto certifies as to its own organization, under penalty of perjury, that to the best of knowledge and belief:

- 1) The prices in this Bid have been arrived at independently without collusion, consultation, communication, or agreement, for the purpose of restricting competition, as to any matter relating to such prices with any other Bidder or with any competitor;
- 2) Unless otherwise required by law, the prices which have been quoted in this Bid have not been knowingly disclosed by the Bidder and will not knowingly be disclosed, directly or indirectly, by the Bidder prior to the opening to any other Bidder or to any competitor; and
- 3) No attempt has been made or will be made by the Bidder to induce any other person, partnership or corporation to submit or not to submit a Bid for the purpose of restricting competition.

BIDDER: DLC Electric, LLC

***BY:** Margaret Cioffi Margaret Cioffi
 (Signature) (Print/Type Name Here)

TITLE Managing Member **SEAL*:**

ADDRESS 479 State Route 40
Troy, NY 12182

PHONE 518-326-8130 **DATED** 1/17/25

FAX 518-326-8132

FID# 26-3478565

**If signed by other than a corporate officer, partner, or owner, a letter of authorization must accompany the Bid with the corporate seal (if applicable).*

**TOWN OF CLIFTON PARK
HIGHWAY DEPARTMENT
NON-COLLUSION AFFIDAVIT**

Every bid or proposal made to a political subdivision of the state or any public department, agency or official thereof where competitive bidding is required by statute, rule, regulation or local law, for work or services performed or to be performed or goods sold or to be sold, shall contain the following statement subscribed by the bidder and affirmed by such bidder as true under the penalties of perjury.

By submission of this bid, each bidder and each person signing on behalf of any bidder, or in the case of joint bid each party thereto, certifies that:

such bid is not made in the interest of or on behalf of any undisclosed person, partnership, company, association, organization or corporation;

such bid is genuine and collusive or sham;

said bidder has not directly induced or solicited any other bidder to put in a false or sham bid and has not directly or indirectly colluded, conspired, connived or agreed with any bidder or anyone else to put in a sham bid, nor that anyone shall refrain from bidding;

said bidder has not in any manner, directly or indirectly, sought by agreement, communication or conference with anyone to fix the bid price of said bidder or of any other bidder, nor to fix any, profit or cost element of such bid price, nor of that of any other bidder, nor to secure any advantage against the public body awarding the contract or anyone interested in the proposed contract;

all statements contained in such bid are true;

and, further, that said bidder has not directly or indirectly, submitted his bid price or any breakdown.

thereof, nor the contents thereof, nor divulged information or data relative thereto, nor paid and will not pay fee in connection therewith to any corporation, partnership, company, association, organization, bid depository, nor to any member or agent thereto, nor to any other individual except to such person or persons as have a partnership or other financial interest with said bidder in his general business.

No bid shall be considered for award, neither shall any award be made where above items have not been complied with.

If the bidder cannot make the foregoing certification, the bidder shall so state and shall furnish with the bid a signed statement which sets forth in detail the reasons why the above items have not been complied with. The bid shall not be considered for award, neither shall any award be made, unless the head of the purchasing unit of the political subdivision, public department, agency or official thereof to which the bid is made, or the appointed designee, determines that such disclosure was not made for the purpose of restricting competition.

Any bid hereafter made to any political subdivision of the state or any public department, agency or official thereof by a corporate bidder for work or services performed or to be performed or goods sold or to be sold, where competitive bidding is required by statute, rule, regulation or local law, and where such bid contains the certification referred to in this section, shall be deemed to have been authorized by the board of directors of the bidder, and such authorization shall be deemed to include the signing and submission of the bid and the inclusion therein of the certificate as to non-collusion as the act and deed of the corporation.

Signature: Margaret Cloffi

Print Name: Margaret Cloffi

Title: Managing Member

Business Address
Of Bidder: 479 State Route 40 Troy, NY 12182

Dated: 1/17/25

**TOWN OF CLIFTON PARK
TRAFFIC SIGNAL MAINTENANCE & REPAIR
Bids Due January 17, 2025, by 3:00 PM, Clerks Office**

A. PREVENTATIVE MAINTENANCE VISITS (ALL TEN (10) SIGNALS)

10 signals X 13 visits per year X Unit Price/Visit Bid Price

\$ 285.00 = \$ 37,050.00

B. REPAIR CALLOUTS (ASSUME 4 CALLOUTS PER YEAR PER SIGNAL)

10 signals X 3 Callouts per Signal X Unit Price/Visit Bid Price

\$ 850.00 = \$ 25,500.00

TOTAL BID PRICE \$62,550.00

(Sum of A & B)

The estimated number of 30 callouts will be used to determine the lowest bidder. The contractor shall be paid on the actual number of callouts made using the unit price entered above.

Total Bid Price, Written in Words:

Sixty Two Thousand, Five Hundred and Fifty Dollars and Zero Cents

*1 hr. Respon
which contractor*

